



JHU/APL
7345-9020
Rev. -
December 1995

ACE

Advanced Composition Explorer

SWEPAM ION

Specific Instrument Interface Specification (SIIS)



The Johns Hopkins University
Applied Physics Laboratory
Johns Hopkins Road, Laurel, Maryland 20723

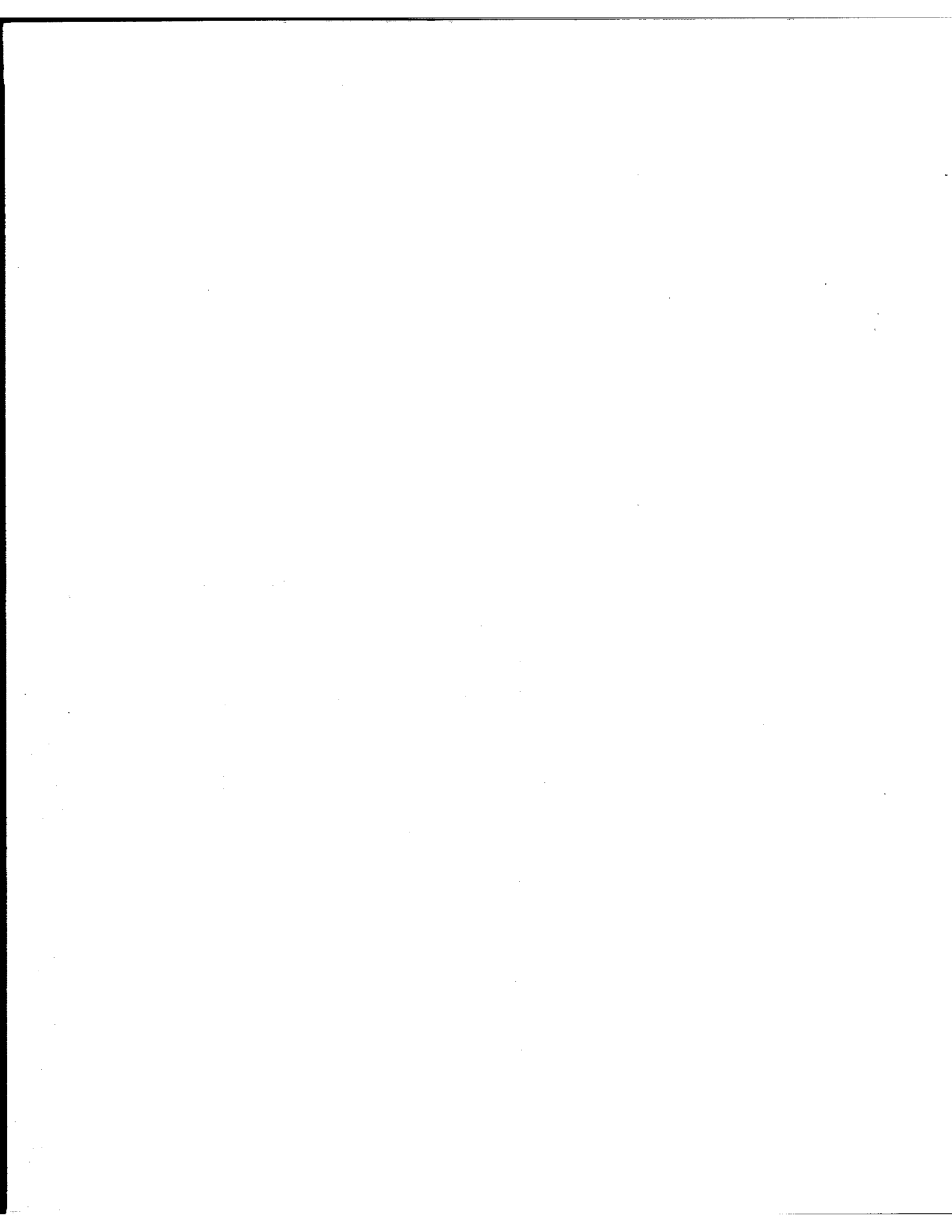

JC

REVISIONS

REV.	BY & DATE	DESCRIPTION	CHECK	APPROVED & DATE



7345-9020-

PART NUMBER	SIZE	NEXT ASSEMBLY	QTY / NA	USED ON	EFFECTIVITY-END ITEM SER. NO.	WEIGHT

DRAWN BY	SECTION	DATE
CHECK	DATE	DATE
GROUP	DATE	DATE
SYSTEM	DATE	DATE
PA ENGR	DATE	DATE
	DATE	DATE

THE JOHNS HOPKINS UNIVERSITY
APPLIED PHYSICS LABORATORY
 JOHNS HOPKINS ROAD LAUREL, MD. 20723

SWEPAM-I
ADVANCED COMPOSITION EXPLORER
SPECIFIC INSTRUMENT INTERFACE
SPECIFICATION

RELEASE: *R K Butcher 2-21-96*

FSCM NO. 88898	SIZE A	DWG. NO. 7345-9020	REV. -
--------------------------	------------------	------------------------------	-----------

REVISION LOG

This log identifies the portions of this specification revised since the formal issue date.

REVISION	PAGE NUMBER	REV DATE	APPROVAL
----------	-------------	----------	----------

FSCM NO. 88898	SIZE A	DWG. NO. 7345-9020
SCALE	DO NOT SCALE PRINT	SHEET iii

TECHNICAL CONTENT APPROVAL

JHU/APL

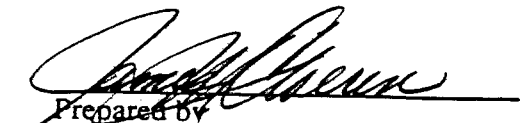
Prepared by
J. M. Cloeren
Spacecraft Instrument Interface Manager

CALTECH

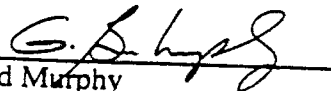

Gerald Murphy
ACE Payload System Engineer

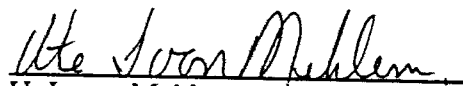
M. C. Chiu
ACE Payload System Engineer

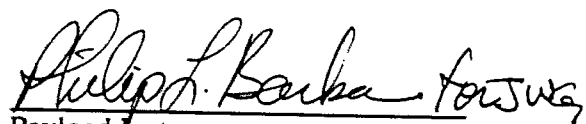

U. I. von Mehlem
Spacecraft System Engineer

INSTRUMENT

Co- Investigator

Payload Instrument
Interface Engineer

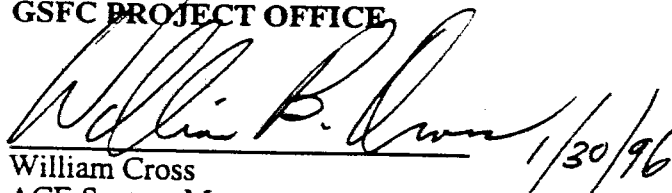
GSFC PROJECT OFFICE

William Cross
ACE System Manager 1/30/96

John Thurber
ACE Observatory Manager 1/30/96

FSCM NO. 88898	SIZE A	DWG. NO. 7345-9020
SCALE	DO NOT SCALE PRINT	SHEET iv

**JHU/APL LEAD ENGINEERS
TECHNICAL CONTENT REVIEW**

R. F. Conde

R. F. Conde
C&DH Subsystems

P. Panneton

P. Panneton
Power Subsystem

10/25/94

J. J. Maynard

J. J. Maynard
Thermal Engineer

J. P. Staiger

J. P. Staiger
I&T Engineer

C.E. Willey

C.E. Willey
Structure

S. Schwartz

S. Schwartz
EMC Engineer

T. Betenbaugh

T. Betenbaugh
Stress Engineer

FSCM NO. 88898	SIZE A	DWG. NO. 7345-9020
SCALE	DO NOT SCALE PRINT	SHEET v

Table of Contents

1.0	General	1-1
1.1	Purpose Of Document	1-1
1.2	Overall Program	1-1
1.3	Applicable Documentation	1-1
1.3.1	NASA Documents	1-1
1.3.2	JHU/APL Documents	1-2
1.3.3	Government Documents	1-2
1.4	Document Configuration	1-3
1.4.1	Update and Change Control	1-3
1.5	Deliverables	1-3
1.6	Instrument Operation And Handling Constraints And Hazards	1-5
2.0	Electrical Interface Requirements	2-1
2.1	General	2-1
2.1.1	C&DH Component Redundancy	2-1
2.2	System Grounding	2-4
2.2.1	General	2-4
2.2.2	Instrument/Sensor Grounding	2-4
2.2.2.1	Single Point Ground (SPG)	2-4
2.2.2.2	Chassis Ground	2-4
2.2.2.3	Primary D.C. Power Circuit Grounds	2-4
2.2.2.4	Secondary D.C. Power Circuit Grounds	2-4
2.2.2.5	Signal Grounds	2-7
2.2.2.6	Shield Grounds	2-7
2.2.2.7	R.F. Bypassing	2-7
2.2.2.8	Variations In Grounding Configuration	2-7
2.2.2.9	Wiring	2-7
2.3	Power	2-7
2.3.1	Power Interface Characteristics	2-7
2.3.1.1	Voltage	2-7
2.3.1.2	Power Allocation	2-9
2.3.1.3	Power Bus Source Impedance	2-9
2.3.1.4	Spacecraft Power Bus Normal Operation	2-9
2.3.1.5	Spacecraft Power Bus Abnormal Operation	2-9
2.3.2	Relay Considerations	2-11
2.3.2.1	Turn-On Transients	2-11
2.3.2.2	Turn-Off Transients	2-14
2.3.3	Power Wiring	2-14
2.3.4	Instrument/Sensor Power Profiles	2-14
2.4	Connectors	2-14
2.4.1	General	2-14
2.4.1.1	Equipment Interface And Test Connector Selection	2-14
2.4.1.2	Magnetic Properties	2-14
2.4.2	ACE Spacecraft/Instrument Interface Connectors	2-17
2.4.2.1	General	2-17
2.4.2.2	Pin Assignments	2-17
2.4.3	Test And GSE Interface Connectors	2-23
2.4.4	Flight Plugs And Locations	2-23

FSCM NO. 88898	SIZE A	DWG. NO. 7345-9020
SCALE	DO NOT SCALE PRINT	SHEET vi

2.4.4.1	Special Connector Plugs	2-23
2.4.5	Payload Stimulus And Monitor Interface	2-23
2.5	Spacecraft Command And Data Handling Subsystem	2-28
2.5.1	C&DH Component Command Acceptance	2-28
2.5.2	Command Execution - Real-Time	2-28
2.5.3	Command Execution - Stored	2-28
2.5.4	C&DH Subsystem Command Interfaces	2-30
2.5.4.1	Logic Pulse Command	2-30
2.5.4.1.1	Description	2-30
2.5.4.1.2	Interface	2-30
2.5.4.2	Data Command	2-30
2.5.4.2.1	Interface	2-34
2.5.4.3	Relay Command (Switched Power)	2-34
2.5.4.3.1	Description	2-34
2.5.4.3.2	Interface	2-38
2.5.4.4	Relay Command (Ordnance)	2-38
2.5.4.4.1	Interface	2-38
2.5.4.4.1.1	Pyrotechnic Firing Voltage	2-38
2.5.4.4.1.2	Firing Circuitry	2-38
2.5.4.4.1.3	Pyrotechnic Safety Short And Arm Plugs	2-38
2.5.4.4.1.4	Pyrotechnic Circuit Shields	2-42
2.5.4.5	Remote Relay Command	2-42
2.6	Spacecraft C&DH Subsystem - Data Handling Portion	2-42
2.6.1	Data Handling Component Interfaces	2-42
2.6.1.1	Serial Digital - Science, Housekeeping, And Memory Dump	2-42
2.6.1.1.1	Description	2-42
2.6.1.1.2	Interface	2-44
2.6.1.2	Digital Telltale	2-50
2.6.1.2.1	Description	2-50
2.6.1.2.2	Interface	2-50
2.6.1.3	0-5v Single Ended Analog Interface	2-50
2.6.1.3.1	Description	2-50
2.6.1.3.2	Interface	2-50
2.6.1.4	0 To +50mv Differential Analog Interface	2-50
2.6.1.4.1	Description	2-50
2.6.1.4.2	Interface	2-55
2.6.1.5	Temperature Sensor Interfaces	2-55
2.6.1.5.1	Description	2-55
2.6.1.5.2	Interface	2-55
2.6.1.6	Sun Pulse And Spin Clock	2-55
2.6.1.6.1	Description	2-55
2.6.1.6.2	Interface	2-55
2.6.1.6.3	Sun Sensor Failure	2-63
2.7	Payload Instrument/Sensor Synchronization Signals	2-63
2.7.1	General	2-63
2.7.1.1	Available Synchronization Signals	2-63
3.0	Mechanical Interface Requirements	3-1
3.1	Instrument Physical Characteristics	3-1
3.1.1	Mass	3-1

FSCM NO. 88898	SIZE A	DWG. NO. 7345-9020
SCALE	DO NOT SCALE PRINT	SHEET VII

3.1.2	Size	3-1
3.1.3	Center Of Mass	3-1
3.1.4	Moments Of Inertia	3-1
3.1.5	Mechanical Interface Drawings	3-1
3.2	Instrument Mounting	3-4
3.2.1	General	3-4
3.2.2	Instrument Mounting Flange Specifications	3-5
3.2.3	Instrument Mounting Hardware Specifications	3-5
3.2.4	Mounting Hole Location Tolerance	3-5
3.2.5	Instrument Mounting Repeatability	3-5
3.3	Alignment	3-5
3.3.1	Definition Of Spacecraft Axes	3-5
3.3.2	Definition Of Instrument/Sensor Optical Axes	3-5
3.3.3	Alignment of Optical Axis	3-10
3.4	Harness Tie Points	3-10
3.5	Payload Instrument/Sensor Load Design	3-10
3.5.1	General	3-10
3.5.2	Load Directions	3-10
3.6	Payload Instrument/Sensor Protective Covers	3-10
3.6.1	Non-Flight Protective Covers	3-10
3.6.2	Flight Covers And Doors	3-10
3.7	Payload Instrument/Sensor Unique Tooling and Handling Fixtures	3-13
3.7.1	Optical Tooling	3-13
3.7.2	Handling Fixtures	3-13
3.8	Payload Instrument/Sensor Accessibility	3-13
3.9	Payload Instrument/Sensor Identification And Marking	3-13
3.10	Payload Instrument/Sensor Maintainability	3-13
4.0	Payload Instrument/Sensor Thermal Interface Requirements	4-1
4.1	General	4-1
4.2	Spacecraft Thermal Design And Control	4-1
4.2.1	Spacecraft-Instrument Interface Temperatures	4-3
4.3	Instrument Sensor Thermal Design And Control	4-4
4.4	Payload Instrument/Sensor Space Environment Temperature Limits	4-8
4.5	Observatory Test Temperature Limits	4-10
4.6	Temperature Sensor Locations	4-10
4.7	Payload Instrument/Sensor Thermal Model Analysis	4-10
4.7.1	Thermal Model	4-10
4.7.2	Geometry Model	4-13
4.8	Thermal Control Devices	4-13
4.8.1	Heaters	4-13
5.0	Payload Instrument/Sensor Magnetic Interface Requirements	5-1
5.1	Instrument/Sensor Degaussing	5-1
5.2	Instrument Magnetic Fields	5-1
6.0	Payload Instrument/Sensor Electromagnetic Interface Requirements	6-1
6.1	Program Requirements	6-1
6.1.1	Objectives	6-1
7.0	Environmental Interface Requirements	7-1
8.0	Payload Instrument/Sensor Contamination Control	8-1
8.1	General	8-1

FSCM NO. 88898	SIZE A	DWG. NO. 7345-9020
SCALE	DO NOT SCALE PRINT	SHEET viii

8.2	Purging	8-1
8.2.1	Purge Connectors	8-1
8.2.2	Purge Gas Flow Rate	8-3
8.2.3	Materials Outgassing	8-3
9.0	Payload Instrument/Sensor Ground Support Equipment	9-1
9.1	General	9-1
9.2	Interface	9-1
9.2.1	Telemetry Interface	9-1
9.2.2	Command Interface	9-1
9.2.3	Sun Sensor Interface	9-1
9.3	General Design Features	9-1
9.3.1	Power	9-3
9.3.2	Identification And Marking	9-3
9.3.3	Calibration	9-3
9.3.4	Documentation	9-3
9.3.5	Radioactive Sources	9-3
9.3.6	Thermal Vacuum Testing	9-4
10.0	Spacecraft Cable Responsibilities	10-1
10.1	General Policy	10-1
10.2	Instrument Concern On Intra-Instrument Cabling	10-1
10.3	Conditions For General Policy Exceptions	10-1
10.4	Procedures For Intra Instrument Cabling Requests	10-3
11.0	Instrument/Sensor Integration	11-1
11.1	Delivery	11-1
11.2	Instrument/Sensor Receiving/Acceptance at JHU/APL	11-1
11.3	Pre-Integration Instrument/Sensor Interface Testing	11-2
11.4	Comprehensive Performance Test	11-2
11.4.1	Comprehensive Performance Test Deliverables.....	11-2

APPENDIX A -- Specific Instrument Mechanical Interface Drawings.....	A-1
APPENDIX B -- Open Action Items	B-1

FSCM NO. 88898	SIZE A	DWG. NO. 7345-9020
SCALE	DO NOT SCALE PRINT	SHEET ix

1.0 GENERAL

This specification details the electrical, mechanical, thermal, and environmental interfaces between the instrument, named on the title page of this document, and the ACE spacecraft when the interface is not already defined by the ACE General Instrument Interface Specification (GIIS). The structure and section numbering of the GIIS and this document are correlated. The requirements of the GIIS apply, unless amended in the corresponding sections of the document. All instrument specific interfaces shall be documented in this specification.

1.1 PURPOSE OF DOCUMENT

This document specifies the interface of ACE spacecraft and the instrument named in the title. This specification assumes interface conformance with the GIIS and shall document unique information and exceptions to the GIIS. **NOTE: Specific Instrument Interface information and comments are shown in bold type and a different font.**

1.2 OVERALL PROGRAM

The Advanced Composition Explorer mission is designed to observe particles, of solar, interplanetary, interstellar, and galactic origins, spanning the energy range from that of the solar wind to galactic cosmic rays. Definitive studies will be made of the abundance of all isotopes from hydrogen to zinc. Experimental studies will extend the isotope abundance range to zirconium.

ACE will be a coordinated effort to determine and compare the isotopic and elemental composition of several distinct samples of matter; the solar corona, the interplanetary medium, the local interstellar medium, and galactic matter. ACE will provide the first extensive tabulation of solar isotopic abundance's based on direct sampling of solar material.

The ACE Observatory will consist of the spacecraft bus and nine science instruments and a data processing unit (S3DPU)

1.2.1 Mission Operations

Mission operations will be conducted by the Goddard Payload Operation Control Center (POCC). All science payload instrument mission operational constraints shall be communicated directly to the cognizant personnel at Goddard.

NOTICE: The spacecraft may be out -of -contact with ground stations for as much as 52 hours.

1.3 APPLICABLE DOCUMENTATION

The documents listed below were used to guide the design of the ACE Spacecraft and the payload instrumentation and therefore are referenced in this Specific Instrument Interface Specification (SIIS), as applicable.

1.3.1 NASA Documents

GSFC-410-ACE-005

ACE Performance Assurance Requirements

FSCM NO. 88898	SIZE A	DWG. NO. 7345-9020
SCALE	DO NOT SCALE PRINT	SHEET 1-1

GSFC-410-ACE-003
GSFC-410-ACE-004

ACE Mission Requirements Document
ACE Configuration Management Procedure

1.3.2

JHU/APL Documents

7345-9001	Design Specification for the ACE Spacecraft
7345-9002	ACE Interface Control Documentation Plan
7345-9003	APL Input to the ACE Observatory to DSN Interface Document
7345-9004	APL Input to the ACE Observatory to Launch Vehicle Interface Document
7345-9100	Spacecraft Assurance Implementation Plan
7345-9006	ACE Observatory Integration and Test Plan
7345-9007	ACE Environmental Definition, Spacecraft and Observatory Test Requirements and Instruments Test Recommendation Document (ACE Environmental Specification)
7345-9100	S/C Assurance Implementation Plan (AIP)
7345-9101	ACE Configuration Management
7345-9010	CRIS - Specific Instrument Interface Specification
7345-9011	SIS - Specific Instrument Interface Specification
7345-9012	ULEIS - Specific Instrument Interface Specification
7345-9013	SEPICA - Specific Instrument Interface Specification
7345-9014	MAG - Specific Instrument Interface Specification
7345-9015	SWICS - Specific Instrument Interface Specification
7345-9016	SWIMS - Specific Instrument Interface Specification
7345-9017	EPAM - Specific Instrument Interface Specification
7345-9018	SWEPAM-E - Specific Inst. Interface Specification
7345-9019	S3DPU - Specific Instrument Interface Specification
7345-9020	SWEPAM-I - Specific Inst. Interface Specification
7345-9102	ACE Contamination Control Plan

1.3.3

Government Documents

GSFC PPL-20	GSFC Preferred Parts List
MIL-STD-975 (Grade 2)	NASA-STD (EEE) Parts List
MIL-M-38510	Microcircuit General Specification
MIL-STD-750	Methods for Semiconductor Devices
MIL-STD-883C	Test Methods and Procedures for Microelectronics
MIL-STD-461B	Electromagnetic Emission and Susceptibility Requirements for the Control of Electromagnetic Interference
MIL-STD-462 (Notice 2)	Measurement of Electromagnetic Interference Characteristics
MIL-STD-480B	Configuration Control
NASA Pub 1124	Outgassing for Spacecraft Materials
NHB 5300.4 (3A-1)	Requirements for Soldering Electrical Connections

FSCM NO. 88898	SIZE A	DWG. NO. 7345-9020
SCALE	DO NOT SCALE PRINT	SHEET 1-2

NHB 5300.4 (1C)
 MIL-D-1000
 MIL-STD-100
 MIL-C-45662
 MSFC-SPEC-522A
 MIL-STD-1629A
 MIL-HDBK-5D

MIL-STD-889
 MIL-HDBK-17A
 MIL-HDBK-23A
 MIL-STD-1522

NSS/HP 1740.1
 MIL-B-5087B

MIL-STD-1541

DOD-E-83578A

GEVS-SE

MIL-P-55110
 MIL-STD-275
 MIL-S-19500
 MIL-STD-202

FED-STD-209

Inspection System Provisions
 Drawings, Engineering and Associated Lists
 Engineering Drawing Practices
 Calibration System Requirements
 Design Criteria for Controlling Stress Corrosion
 Failure Modes, Effects and Criticality Analysis
 Metallic Materials and Elements for Aerospace
 Vehicle Structures
 Dissimilar Materials
 Plastics for Aerospace Vehicles
 Structural Sandwich Components
 Standard General Requirements for Safe Design and
 Operation of Pressurized Missile and Space
 Systems
 NASA Aerospace Pressure Vessel Safety Standards
 Bonding, Electrical and Lightning Protection for
 Aerospace Systems
 Electromagnetic Compatibility Requirements for
 Space systems
 Explosive Ordnance for Space Vehicles, General
 Specifications for
 General Environmental Verification Specification
 for STS and ELV Payloads, Subsystems and
 Components
 Printed Wiring Boards
 Printed Wiring for Electronic Equipment
 General Specification for Semiconductors
 Test Methods for Electronic and Electrical
 Components
 Federal Standard Clean Room and Work Station
 Requirements, Controlled Environment

1.4 DOCUMENT CONFIGURATION

1.4.1 Update and Change Control

The data contained in this document represent the current definition of the ACE Spacecraft Interface characteristics and limitations. This document, after formal release, shall be revised only through the formal change control procedures as described in the APL ACE Configuration Management Plan.

1.5 DELIVERABLES

Each instrument/sensor provider shall deliver the items listed below for, or in support of, Observatory integration. Ground support equipment (GSE) consisting of hardware, software, and procedures, shall be shipped simultaneously or prior to the delivery of flight hardware. Safety rules, handling constraints and procedures, analytical models, analyses, drawings, test plans and procedures, test results, etc., shall be required prior to instrument delivery or as specified in the SIIS. **Deliverables and their due dates are listed in Figure 1.5-1.**

FSCM NO. 88898	SIZE A	DWG. NO. 7345-9020
SCALE	DO NOT SCALE PRINT	SHEET 1-3

Figure 1.5-1 SWEPAM-I Instrument Deliverables

Instrument Development Team Deliverables

The IDT shall provide the following hardware, materials and documentation to support the integration and test of the SWEPAM-I instrument with the spacecraft, starting with the initial integration and continuing through launch.

- a.) SWEPAM-I flight instruments with flight software
- b.) Applicable portions of the Acceptance Data Package as required to verify the SWEPAM-I instrument is ready for spacecraft integration
- c.) SWEPAM-I test connector buffer box w/cables and installation procedure
- d.) SWEPAM-I test connector flight cover with red tag "flags" to be installed at all times when a flight cover is not installed
- e.) SWEPAM-I test connector non-flight high voltage disable plug,
- f.) SWEPAM-I high voltage make/break flight covers
- g.) Charcoal Filter for the purge port during thermal vacuum testing
- h.) Light Baffle for the pump-out port in the flight configuration
- i.) Aperture door mechanism
- j.) SWEPAM Test Monitoring Terminal compatible with the ITOCC
 - Desk Top Computer
 - Laser Printer
 - Extra Magnetic or Optical Data Storage
 - Spacecraft Simulator and all test cables for post ship test
- k.) SWEPAM-I Thermal Math Model
- l.) Mechanical Interface Drawing with information required by paragraph 3.1.5
- m.) Input to the APL integrated Observatory Test Plans and Procedures including
 - GSE setup requirements
 - CPT Requirements
 - LPT Requirements
- n.) Pre/Post Observatory Vibration/Acoustic Test Procedure
- o.) Pre/Post Observatory Thermal Vac Procedures
- p.) Pre Launch Close Out procedure

FSCM NO. 88898	SIZE A	DWG. NO. 7345-9020
SCALE	DO NOT SCALE PRINT	SHEET 1-4

Figure 1.5-1 SWEPAM-I Instrument Deliverables (Cont.)

Spacecraft Development Team Deliverables

The SDT shall provide the following hardware, materials and documentation to support the integration and test of the SWEPAM-I with the spacecraft starting with the initial integration and continuing through launch.

- a.) Instrument to Deck mounting hardware as specified in paragraph 3.2.3
- b.) Connector mating hardware
- c.) MLI thermal blankets
- d.) Nitrogen purge gasses through the spacecraft purge manifold
- e.) Spacecraft to Instrument cabling

FSCM NO. 88898	SIZE A	DWG. NO. 7345-9020
SCALE	DO NOT SCALE PRINT	SHEET 1-5

1.6

INSTRUMENT OPERATION AND HANDLING CONSTRAINTS AND HAZARDS

Each instrument/sensor experimenter shall summarize all constraints and hazards, which are applicable, to the handling and operation of their respective hardware. **These constraints and hazards shall be listed in Figure 1.6-1.**

FSCM NO. 88898	SIZE A	DWG. NO. 7345-9020
SCALE	DO NOT SCALE PRINT	SHEET 1-6

Figure 1.6-1 SWEPAM-I Instrument Operation and Handling Constraints

As a rule, the SWEPAM-I instrument shall only be handled and worked by the IDT. This includes moving the instrument between storage and the spacecraft. Should the SDT identify a need to handle and/or work the instrument, an IDT approved procedure shall be used.

Storage and handling environment

During any period of storage or handling of the SWEPAM-I either on the spacecraft or while separate from the spacecraft, the following environment shall be observed:

- a.) Relative humidity in the range 30% to 70%
- b.) Temperature within a range of +5°C to +35°C
- c.) Rate of temperature change is not to exceed 10°C/hr

The SWEPAM-I is a tightly closed assembly and it is possible for trapped air to have a dew point different than the ambient environment. Care should be taken to prevent application of power if there is any concern that condensation (dew or frost) may be present internal to the box.

Electrostatic Sensitivity

The SWEPAM-I contains parts which can be damaged by electrostatic discharges from either direct contact with the part or induced by electrostatic fields. For the most part the instrument's covers insure protection to these parts during most instrument handling typical in the spacecraft integration and test environment. One path for possible damage is through unterminated connectors regardless of whether the connector is an interface connector or a test connector. When not in use, all unterminated connectors shall be covered with conductive or anti static covers. When mating connectors, ESD protective clothing, gloves and grounding straps shall be used. When not cabled to the S/C or the SWEPAM-GSE, a clip-on jumper strap shall be installed between the E-Box and the sensor assembly. This effectively connects the instruments signal ground to chassis ground for improved ESD control. The jumper must be removed for proper operation of the instrument. Failure to do so however, will not damage the instrument, S/C or GSE.

Handling Mechanical Shock

The SWEPAM-I is not extremely sensitive to mechanical shock but it should still be handled as befits a flight instrument.

FSCM NO. 88898	SIZE A	DWG. NO. 7345-9020
SCALE	DO NOT SCALE PRINT	SHEET 1-7

Figure 1.6-1 SWEPAM-I Instrument Operation and Handling Constraints (Cont.)

High Voltage Safety

The SWEPAM-I has a -2kv and a -4Kv power supply. While these supplies are not considered a health hazard since the maximum supply current is so small (less than 150 micro amps), precautions need to be taken since a high voltage arc can startle one to move too quickly resulting in incidental injury or damage to the spacecraft. Damage to the high voltage power supply is also possible with sustained arcing. In the heritage design, these voltages were present on the outside of the instrument where mechanical and bodily contact can be made. For ACE, the IDT has added protective covers to preclude exposure to these high voltage sources.

Test Environment Constraints

The SWEPAM-I has a make/break arrangement between the CEM high voltage power supply and the sensor. When not connected to the sensors, the CEM high voltage power supply is connected to a dummy load resistor. At no time shall the CEM supply be operated without a load. At no time during observatory testing shall high voltage be connected to the CEMs or Analyzer. Both SWEPAM-I high voltage power supplies can be operated at ambient and in high vacuum. During the observatory thermal vacuum test, these supplies shall not be energized until the spacecraft has been at pressures less than 1×10^{-5} torr for at least 12 hours. At the latest possible time before launch the IDT shall remove the dummy loads and connect the CEMs to the high voltage supplies. Once this connection has been made, the high voltage supplies SHALL NOT be operated until after launch.

Purge Constraints/Safety

The SWEPAM-I sensor is stored and shipped sealed from the environment with a cap on the purge port and environmental seals the instrument's aperture and pump-out port. Before Observatory thermal vacuum testing the IDT shall replace the seal on the purge port with a charcoal filter allowing the sensor to "breathe" through the purge port without risk of particulate or moisture contamination. At the conclusion of the vacuum test, the chamber shall backfilled with dry nitrogen and as soon a feasible the IDT will re cap the purge port.

After spacecraft environmental testing, and purge is available, the IDT will remove the environmental seals from the aperture and pump-out port, install the pump-out port light baffle, install the aperture door mechanism, remove the purge port cap and assist the SDT to install the purge line. From this time and through umbilical separation at launch, the SWEPAM-I will need to be purged with nitrogen per the requirements of paragraph 8.2.

FSCM NO. 88898	SIZE A	DWG. NO. 7345-9020
SCALE	DO NOT SCALE PRINT	
	SHEET	1-8

2.0 ELECTRICAL INTERFACE REQUIREMENTS

2.1 GENERAL

The Command and Data Handling (C&DH) component receives, decodes and distributes spacecraft commands. It also receives, formats, stores, and transmits telemetry data from the instrument/sensor payloads and the spacecraft.

This C&DH subsystem provides the electrical interface between the ACE Spacecraft and the payload instruments/sensors.

Figure 2.1-1 presents a functional overview of the electrical interfaces between the spacecraft and the payload instruments/sensors.

2.1.1 C&DH Component Redundancy

The C&DH subsystem will be redundant, thus providing complete interface redundancy to all instruments/sensors. Each instrument/sensor shall provide interfaces to each of the redundant C&DH spacecraft subsystems. These instrument interfaces shall insure that a failure on one side of the interface does not propagate to or affect operation of the redundant side.

Each instrument shall provide a method by which the C&DH component with active data handling functions can be selected by ground command. The ground command may be a data command or a logic pulse command.

For example, each instrument could generate a data handling select bit that would enable the data handling, sun pulse, and spin clock interfaces from one C&DH component, and disable the data handling, sun pulse, and spin clock interfaces from the other interfaces. One way to implement the data handling select bit is with a data command. One data command bit pattern (op code) could be used to configure instrument electronics to use the data handling, sun pulse, and spin clock interfaces from one C&DH component, and another bit pattern could be used to select the data handling, sun pulse, and spin clock interfaces from the other C&DH component.

Note: Each instrument/sensor shall have provisions to monitor and accept commands from either of the redundant spacecraft command components.

FSCM NO. 88898	SIZE A	DWG. NO. 7345-9020
SCALE	DO NOT SCALE PRINT	SHEET 2-1

Figure 2.1-1 Functional Block Diagram of SWEPAM-I Electrical Interface

ALSO SEE 7345-2216 IN APPENDIX A.

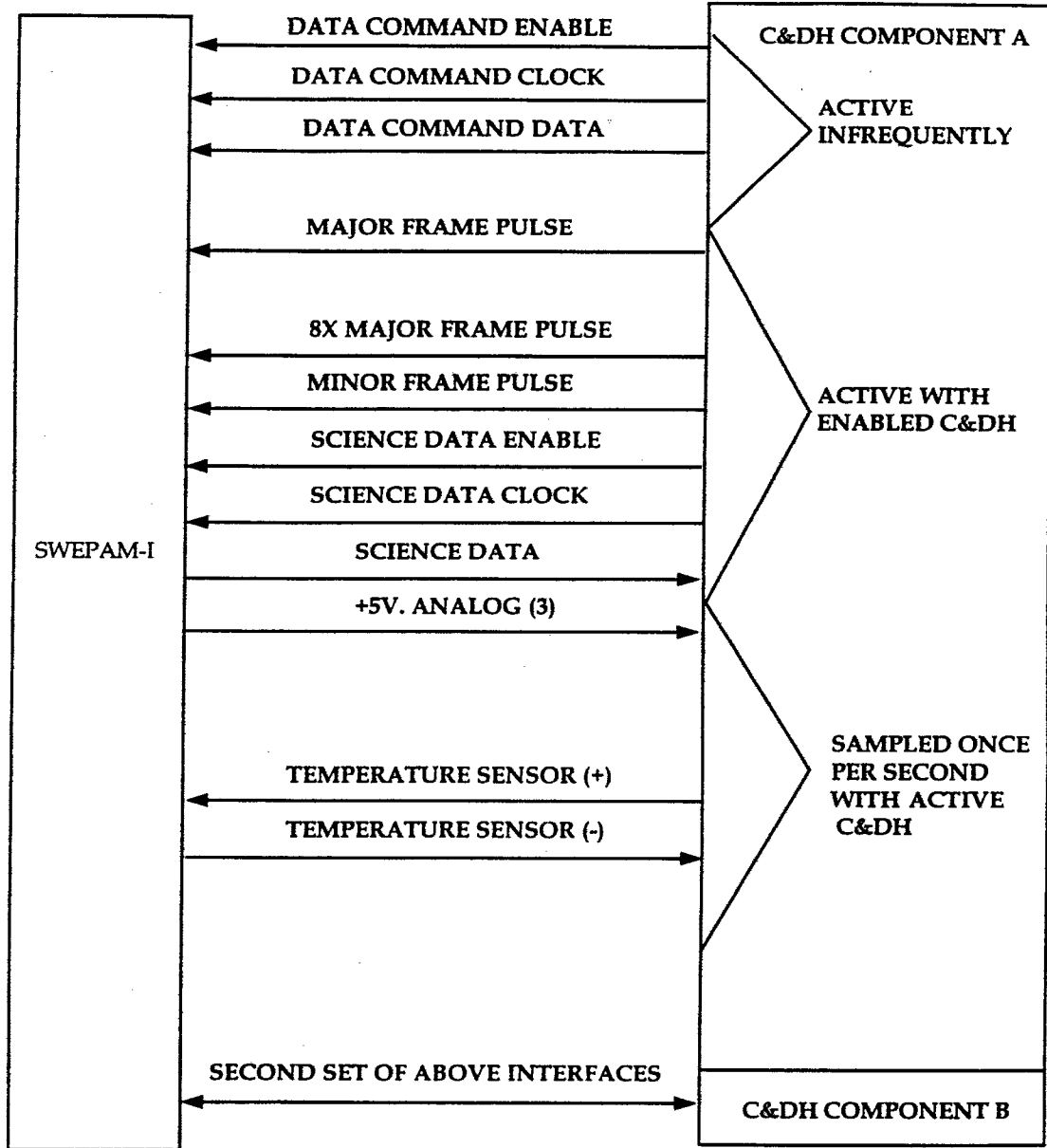

FSCM NO.	SIZE	DWG. NO.
88898	A	7345-9020
SCALE	DO NOT SCALE PRINT	SHEET 2-2

Figure 2.1-1 Functional Block Diagram of SWEPAM-I Electrical Interface (Cont.).

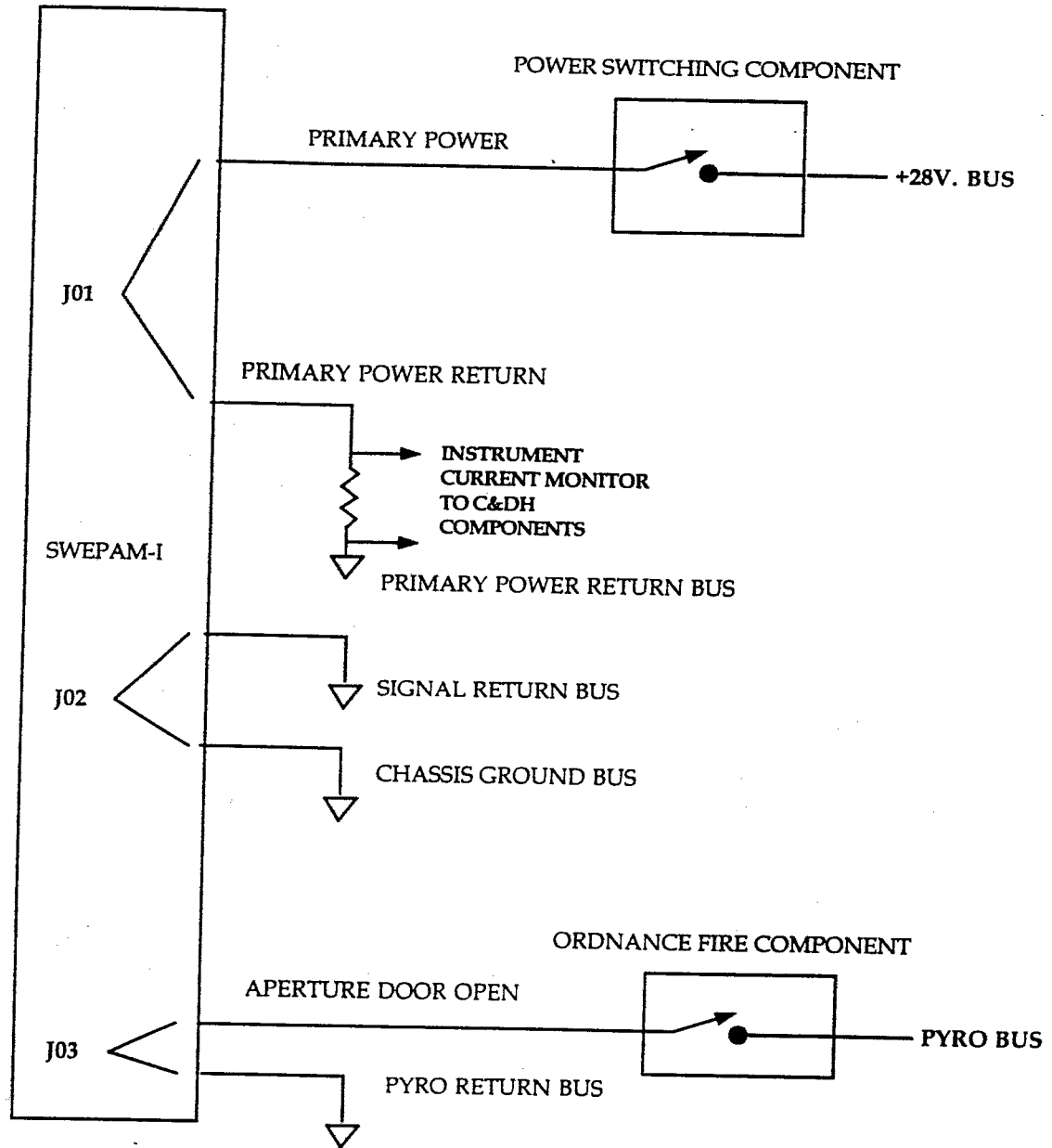

FSCM NO.	SIZE	DWG. NO.
88898	A	7345-9020
SCALE	DO NOT SCALE PRINT	SHEET 2-3

2.2 SYSTEM GROUNDING

2.2.1 General

The ACE Spacecraft will employ a hybrid ground system to meet the many requirements of the Observatory and minimize electromagnetic and magnetic coupling between the payload instruments/sensors. A generalized master grounding diagram is shown in Figure 2.2.1-1. Instruments which have their secondary grounds referenced to the instrument chassis will be treated in detail in the SIIS.

2.2.2 Instrument/Sensor Grounding

2.2.2.1 Single Point Ground (SPG)

A Single Point Ground is provided on the ACE Spacecraft structure. For the payload instruments/sensors, the SPG shall be the bussing point to the spacecraft structure for primary (BUS) power returns only. The resistance between the SPG and the spacecraft structure shall not exceed 0.025 ohm.

2.2.2.2 Chassis Ground

Every instrument/sensor chassis shall be electrically bonded directly to the spacecraft structure. Instruments which are thermally isolated shall be bonded by means of grounding straps. The resistance between the instrument/sensor structures and the spacecraft structure shall not exceed 0.025 ohm. Note: S/C shall provide grounding straps. Details are shown in Figure 2.2.2.4-1.

2.2.2.3 Primary D.C. Power Circuit Grounds

Primary power returns from the instrument/sensor power conversion circuitry shall be returned to the spacecraft primary power return bus as a twisted wires through the TLM current sensing resistors.

In each instrument, the dc resistance between the primary power leads, the primary power return leads and the instrument chassis shall be not less than 1 megohm.

2.2.2.4 Secondary D.C. Power Circuit Grounds

Secondary power returns, which have been isolated from the primary power return by means of a DC-to-DC converter, shall be referenced to the spacecraft single point ground (SPG). **Instruments/sensors that must have secondary power returns common to the instrument chassis will be considered on a case-by-case basis. Specific Instrument grounding schemes are documented in Figure 2.2.2.4-1.**

Instruments/sensors that distribute power from the secondary side of a common power supply located in one component, to electronics located in another component, by means of an intra-instrument harness/cable, shall provide a secondary power return lead that isolates return currents from the spacecraft chassis.

FSCM NO. 88898	SIZE A	DWG. NO. 7345-9020
SCALE	DO NOT SCALE PRINT	SHEET 2-4

Figure 2.2.1-1 Spacecraft Master Grounding Diagram

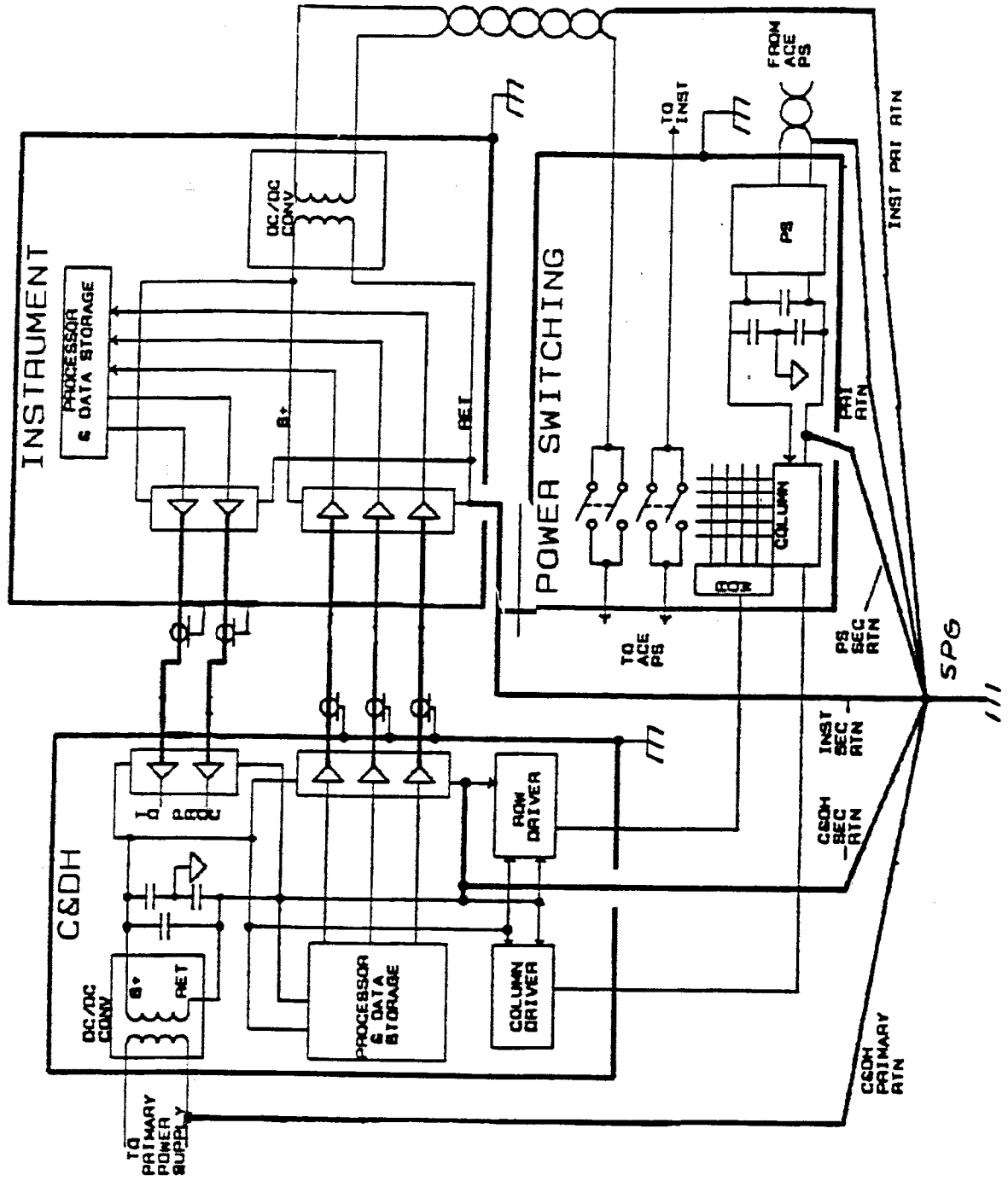

FSCM NO. 88898	SIZE A	DWG. NO. 7345-9020
SCALE	DO NOT SCALE PRINT	SHEET 2-5

Figure 2.2.2.4-1 SWEPAM-I Instrument Grounding Diagram

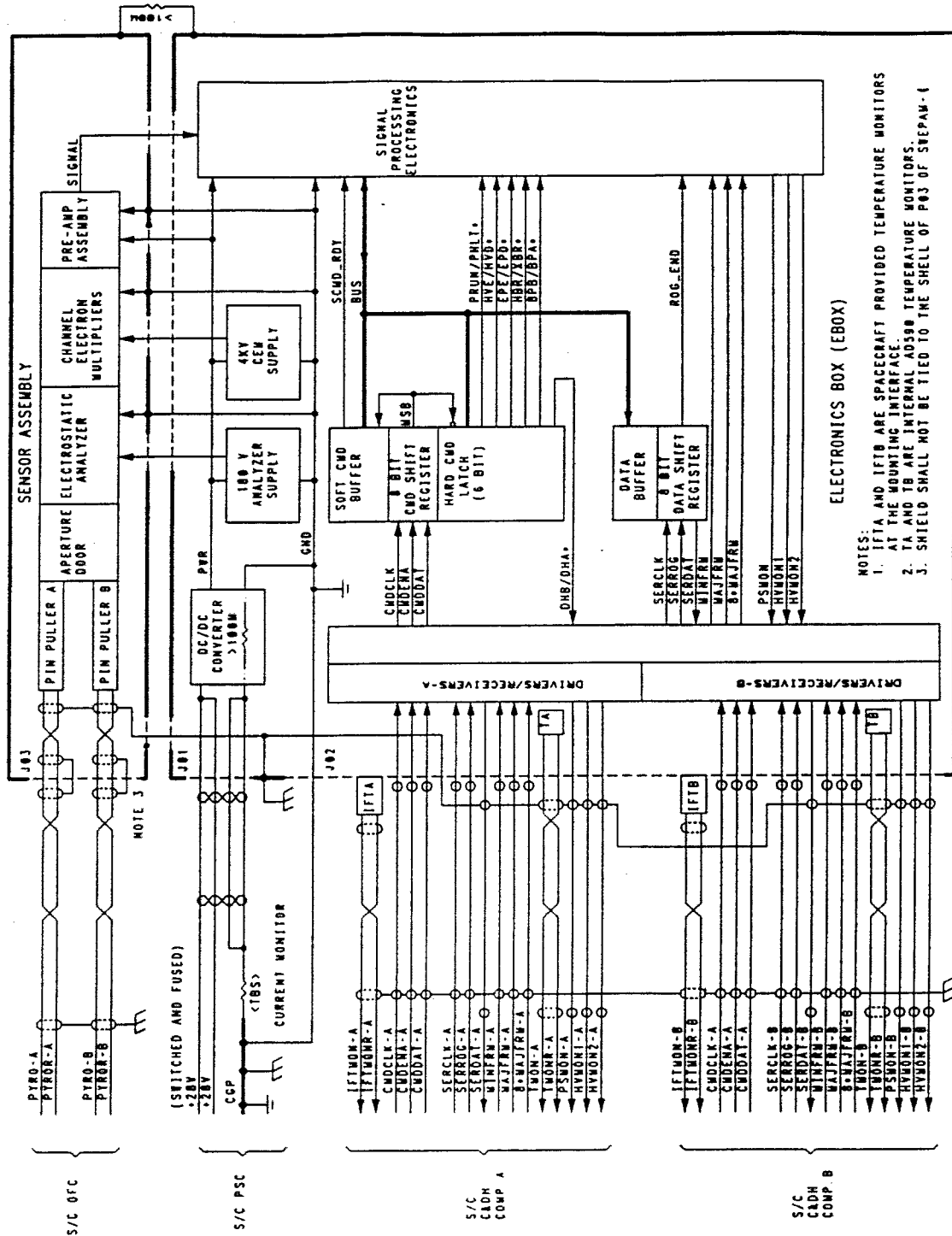

- NOTES:
1. IFTA AND IFTB ARE SPACECRAFT PROVIDED TEMPERATURE MONITORS AT THE MOUNTING INTERFACE.
 2. TA AND TB ARE INTERNAL ADS98 TEMPERATURE MONITORS.
 3. SHIELD SHALL NOT BE TIED TO THE SHELL OF P03 OF SWEPAM-1

FSCM NO.	SIZE	DWG. NO.
88898	A	7345-9020
SCALE	DO NOT SCALE PRINT	
	SHEET	2-6

2.2.2.5 Signal Grounds

The signal return conductor is the return path for all low voltage signals generated or used by the instrument/sensor. This signal return/ground shall be isolated from the primary power supply and returns leads by at least 1 megohm when not connected to the SPG.

2.2.2.6 Shield Grounds

At least one contact on each interface connector shall be provided for the purpose of shield grounding. Shields shall be grounded on the sending side only (except pyro shielding). Helo ring termination is acceptable.

2.2.2.7 R.F. Bypassing

Primary power and return lines may be bypassed to the instrument/sensor chassis with feed-through, low inductance type, capacitors. The capacitors shall be less than, or equal to .01 microfarad per lead.

2.2.2.8 Variations in Grounding Configuration

Certain variations to the grounding configuration described in the preceding paragraphs may be required to facilitate the use of existing equipment designs. **These variations shall be identified in Figure 2.2.2.4-1.**

2.2.2.9 Wiring

The use of twisted wire for all power and pyro lines is required. The use of the spacecraft structure as a signal return is to be avoided. Any method of wiring which will reduce stray magnetic fields should be implemented. All pyro firing wiring shall be twisted and shielded. This wiring format shall extend from the pyro connector to the pyro device. Power wiring is twisted but not shielded.

2.3 POWER

Power will be distributed to the instruments by relays in the Power Switching Component (PSC). The PSC is part of the C&DH subsystem. Each relay in the PSC may be controlled by either of the two redundant C&DH Components. Control of the relays is redundant, through the use of redundant relay coils; the relay contacts used to switch power are also redundant. The power switched by the relays will be provided over redundant wires to each instrument/sensor. Figure 2.3-1 illustrates a typical instrument/sensor power interface.

2.3.1 Power Interface Characteristics

2.3.1.1 Voltage

The spacecraft Power Bus shall provide $28V \pm 2\%$, excluding transients and ripple. Power will be provided by a two wire system (power and return) with the low side referenced to the spacecraft primary ground bus. Instrument/Sensor designers should consider

FSCM NO. 88898	SIZE A	DWG. NO. 7345-9020
SCALE	DO NOT SCALE PRINT	SHEET 2-7

Figure 2.3-1 Typical Instrument/Sensor Power Switching Interface

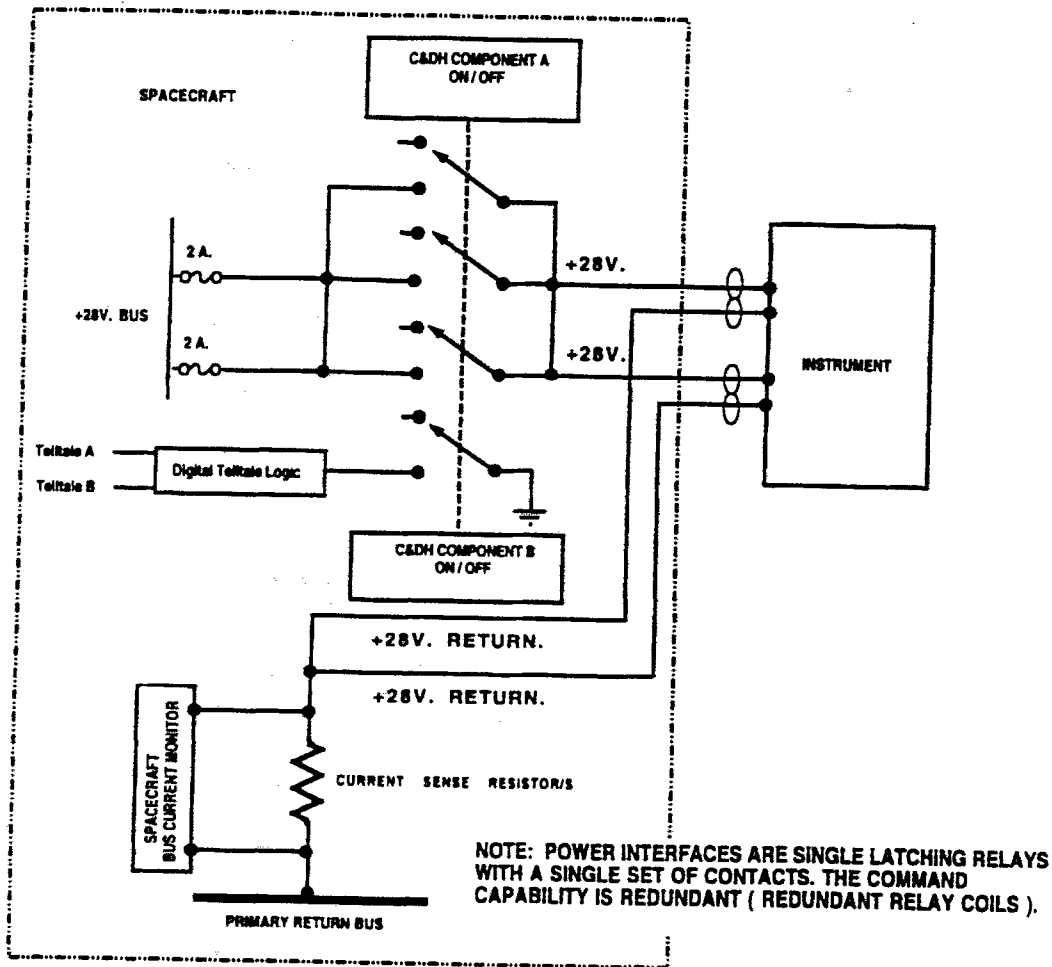

FSCM NO. 88898	SIZE A	DWG. NO. 7345-9020
SCALE	DO NOT SCALE PRINT	SHEET 2-8

the voltage drop at their instrument due to harness losses. The power harness shall be a minimum of two number 22 wires for both power source and return. The maximum harness length shall not exceed six feet.

2.3.1.2 Power Allocation

The power allocation for each instrument/sensor shall be established and specified in each of the Specific Instrument Interface Specifications. After agreement on the power allocations, any change in power shall require the approval of a formal change request. Power estimates shall be provided to the ACE spacecraft interface manager and designers by each of the instrument/sensor experimenters; these estimates shall include no margins.

2.3.1.3 Power Bus Source Impedance

The S/C power bus source impedance estimate is shown in Figure 2.3.1.3-1.

2.3.1.4 Spacecraft Power Bus Normal Operation

Under normal operating conditions the spacecraft power bus shall have the following characteristics:

Bus voltage: The bus shall remain at +28 VDC \pm 2% except for load turn-on transients.

Load turn-on transient: During load turn-on, the bus shall be limited to +26.88V and shall return to +28VDC \pm 2% within 15 milliseconds. During this time, the maximum current step change is 5A (for transponder turn-on).

Load turn-off transient: The bus turn-off transient is limited to +32V and will return to +28 \pm 2% within 15 milliseconds.

Ripple: The bus maximum ripple (at the user component) shall be less than 350mV p-p. Ripple bandwidth shall not exceed 100 MHz and shall be measured with a bandwidth >100 MHz.

Spikes: The bus maximum repetitive spike voltage shall be less than 0.5Vp-p. Short duration (less than 50ms) aperiodic transients and short duration components of long aperiodic transients shall be limited to a peak value less than three times the normal load voltage (i.e., 84V) and an impulse strength less than 140mV seconds.

2.3.1.5 Spacecraft Power Bus Abnormal Operation

In the event of an overcurrent or undervoltage condition, the bus is protected by the C&DH subsystem which removes the instruments from the bus and then, if the fault persists, removes the non-critical spacecraft subsystems. Additional protection from short circuit loads is provided by the fuses in line with all bus loads.

FSCM NO. 88898	SIZE A	DWG. NO. 7345-9020
SCALE	DO NOT SCALE PRINT	SHEET 2-9

Figure 2.3.1.3-1 Power Bus Source Impedance

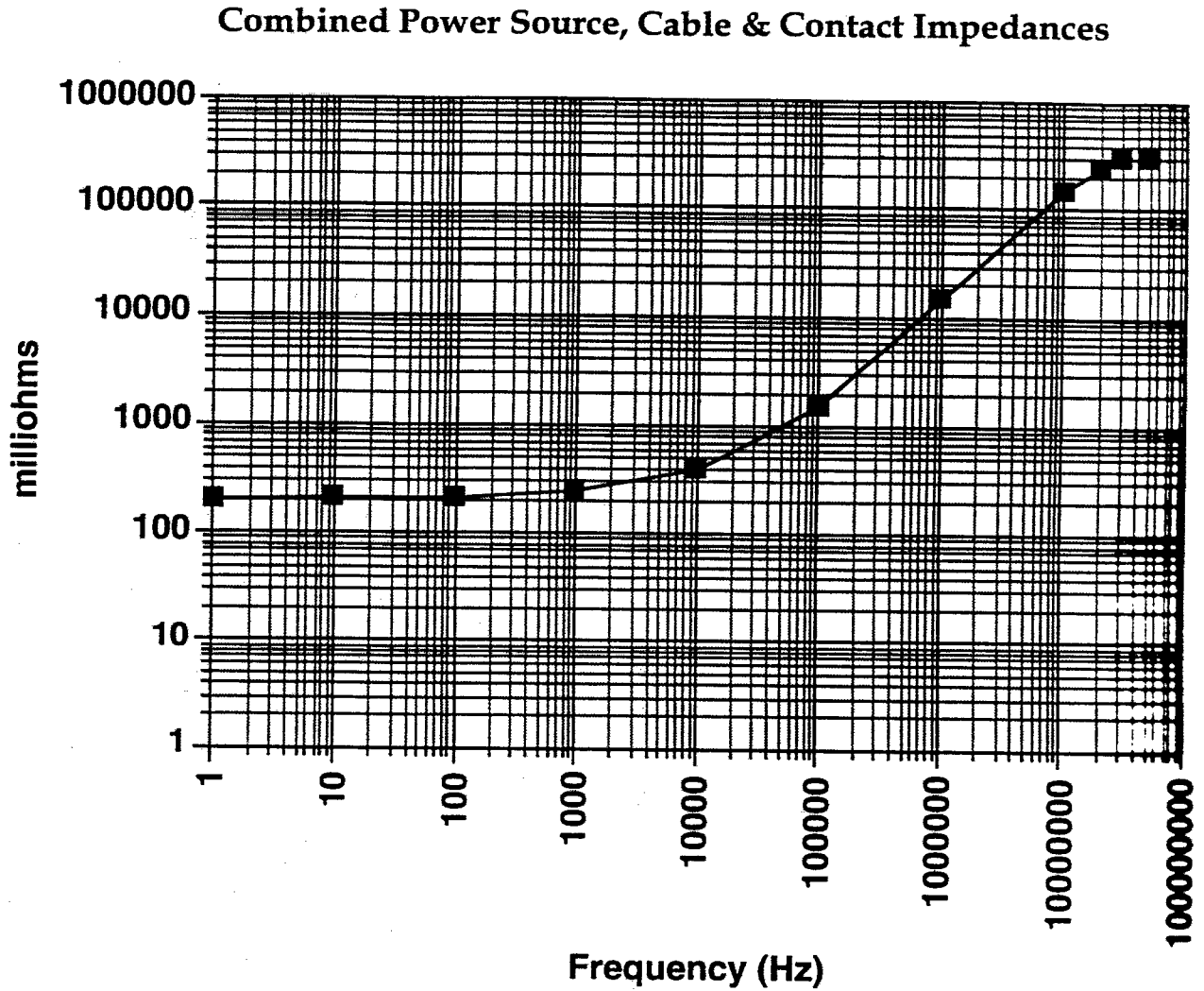

Data includes the power source, connectors, harness, relay contacts, solder joints and telemetry impedance seen by a load five feet (maximum instrument harness length) from the power source.

FSCM NO. 88898	SIZE A	DWG. NO. 7345-9020
SCALE	DO NOT SCALE PRINT	SHEET 2-10

During fault clearing, the characteristics of the bus are as follows:

Bus voltage: Fault clearing shall not exceed 10 seconds. In the event of a bus short to ground (worst case fault), the main bus voltage may be brought down to the battery voltage (approximately 19.6 volts). This assumes that the short will not cause the component fuse to open during the 10 seconds. All the non-critical loads (and the ballast (shunt resistors) loads) will be removed from the bus during the 10 seconds. When the fuse opens, only the critical spacecraft loads are powered and the bus voltage can jump to 36.6 volts for 15 milliseconds max before the bus returns to $28 V \pm 2\%$.

During integration and test, there exists a small possibility of faults which could produce a bus voltage between 0 to 30 V for 2 minutes.

Surges: Surges shall not exceed the range +18.9 to + 38 volts. The lower voltage, below the 26 v main bus trip point, shall last no longer than the time it takes to remove the non-critical loads (within 10 seconds). The upper voltage shall recover to normal operating voltage within 15 milliseconds.

2.3.2 Relay Considerations

The Power Switching and Ordnance Fire Components are made up of 2, 5 and 10 amp. rated relays. These relays come in the latching and non-latching varieties. Typically the latching relays have 2 to 4 poles and the non-latching relays have 2 to 3 poles. The number of relays in a given component is dependent on the current rating (size) of relays and the configuration called out by the users.

Each C&DH Component issues commands to the relays in the Power Switching and Ordnance Fire Component with a selectable 20, 40, 60 or 80 millisecond pulse width. This action translates to a guaranteed 10, 30, 50, or 70 millisecond non-latching relay contact closure.

2.3.2.1 Turn-on Transients

Peak turn-on transients shall not exceed the levels given in the text below and shall reach steady state operating current within 300 milliseconds. The turn-on transient maximum current rate of change shall not exceed 20mA per microsecond. See Figure 2.3.2.1-1. **Specific instrument turn-on transient is shown in Figure 2.3.2.1-2.**

Instruments > 1A. The initial inrush current shall not exceed 2 times the normal operating current for the first 300 ms and 1.5 times the steady state current for the remaining time not to exceed 300 milliseconds for the total transient.

Instruments < 1A. The initial inrush current shall not exceed 2 amp for the first 300ms and 1.5 amps for the remaining time not to exceed 300 milliseconds for the total transient.

FSCM NO. 88898	SIZE A	DWG. NO. 7345-9020
SCALE	DO NOT SCALE PRINT	SHEET 2-11

Figure 2.3.2.1-1 Envelope of Allowable In-rush Current

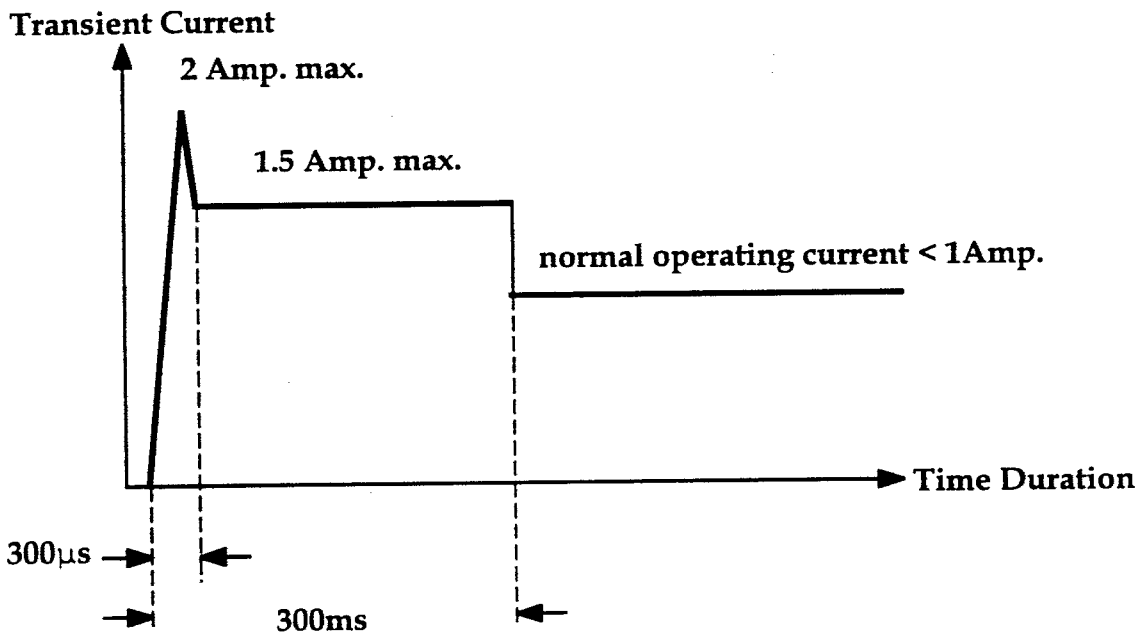
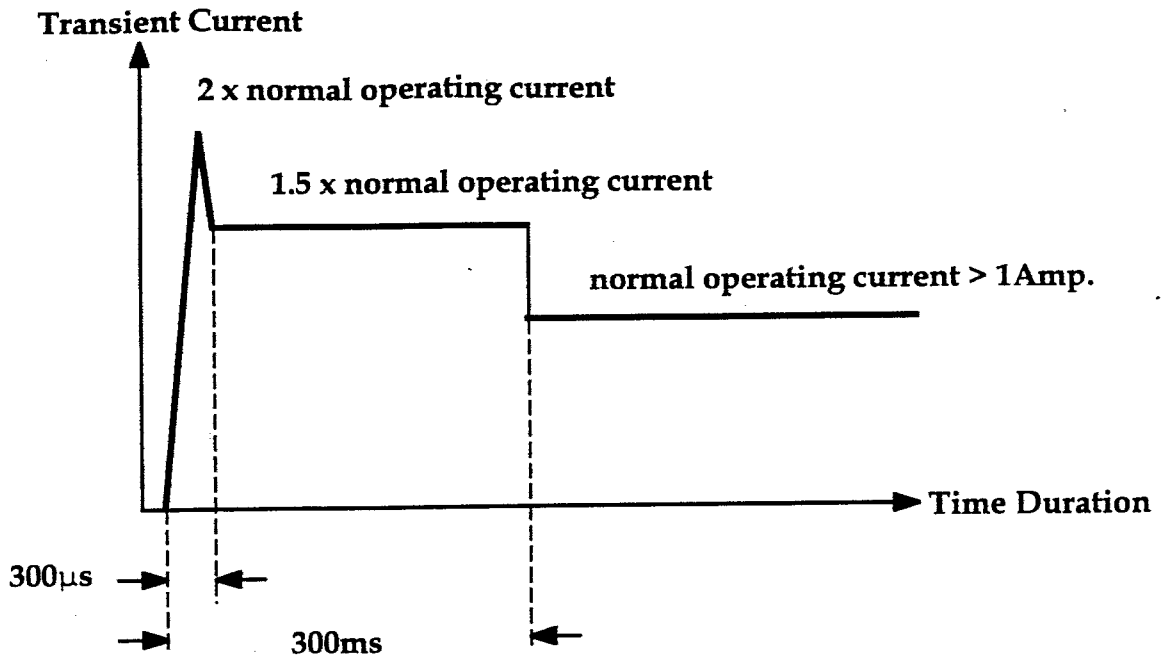

FSCM NO.	SIZE	DWG. NO.
88898	A	7345-9020
SCALE	DO NOT SCALE PRINT	SHEET 2-12

Figure 2.3.2.1-2 SWEPAM-I Instrument Turn-on Transient Requirements

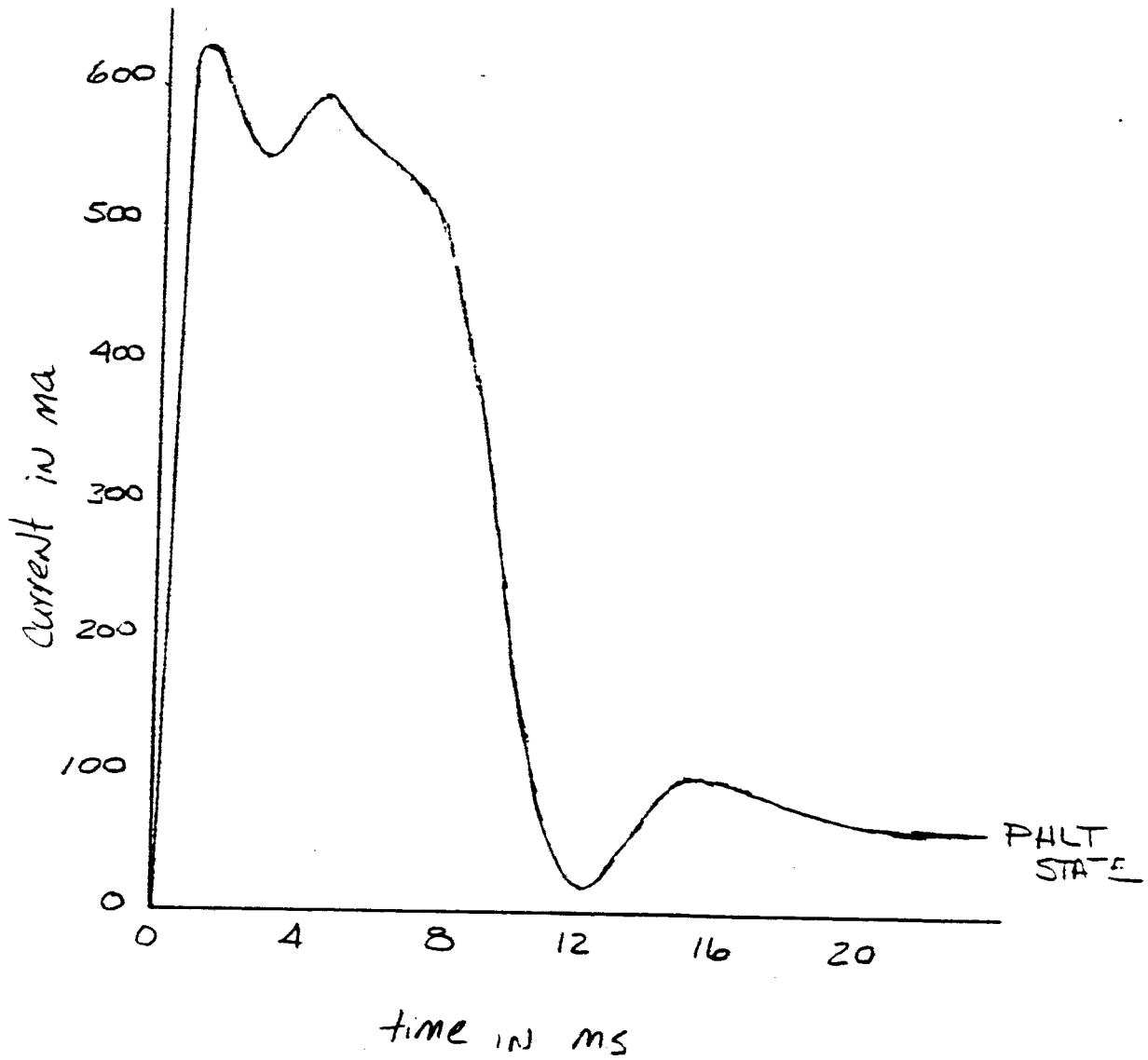

FSCM NO. 88898	SIZE A	DWG. NO. 7345-9020
SCALE	DO NOT SCALE PRINT	SHEET 2-13

2.3.2.2 Turn-off Transients

All inductive loads associated with the users, such as coils, shall be provided with suppression circuits to prevent damage to relay contacts, due to excessive transients during power interrupts.

2.3.3 Power Wiring

Power will be distributed via unshielded twisted wires (quads) as described in Paragraph 2.2.2.3.

2.3.4 Instrument/Sensor Power Profiles

Each instrument/sensor experimenter shall provide power profiles for all normal and known abnormal operating modes of their respective equipment, including turn-on and turn-off. The specific instrument power profiles are shown in Figure 2.3.4-1.

2.4 CONNECTORS

2.4.1 General

2.4.1.1 Equipment Interface and Test Connector Selection

Interface and test connectors shall be Aerospace/Military designs for severe environmental applications. In order to minimize program connector types and reduce cost, it is desirable that standard connectors be used for all new equipment designed for the ACE program.

Preferred types are:

- a) Rectangular connectors meeting the requirement of GSFC S-311-P-407, S-311-P-409, or S-311-P-10. (HD and HDD "D" type connectors)

If an instrument/sensor experimenter uses a connector not listed above, the instrument/sensor experimenter shall provide JHU/APL mating connectors for all interfaces with the spacecraft. The experimenter shall supply all mating connectors which do not directly interface with the spacecraft no matter what connector type is used. (See also Section 10.) Specific instrument connector data are shown in Figure 2.4.1.1-1.

2.4.1.2 Magnetic Properties

The payload instrument/sensor interface connectors shall be made of non-magnetic materials in order to limit magnetic contamination of the ACE Observatory. Exceptions shall be noted in Figure 2.4.1.1-1. Samples of non-conforming connectors shall be provided for magnetic testing.

FSCM NO. 88898	SIZE A	DWG. NO. 7345-9020
SCALE	DO NOT SCALE PRINT	SHEET 2-14

Figure 2.3.4-1 SWEPAM-I Power Profile

The SWEPAM-I has four power states;

Power off (OFF) = 0 watt: The SWEPAM-I uses no bias or standby power.

Processor Halt (PHLT) = (<3.4W.) This state can be achieved from the OFF, PRUN or HVON state. In the PHLT state, the low voltage power supply is on, high voltage supplies are disabled, the command interface can receive and process hardware commands but the processor is held in reset and therefore unable to receive software commands. The instrument would not normally be operated in this state any longer than it took to give it the commands to configure the hardware and start the processor. To allow for power supply stabilization and the de-assertion of the power-on-rest signal, 2 seconds <TBR> should be allowed between the (SWEPAM) I_ON command and any other commands to the instrument. As noted in paragraph 2.3.1.5, there is no problem with removing power from the SWEPAM-I from any configuration, yet it is still desirable when possible to send a (SWEPAM) I_HLT command prior to removing power. This assures the processor will not execute an unprogrammed sequence as its power decays. The (SWEPAM) I_OFF command can occur immediately after the (SWEPAM) I_HLT command.

Processor Run (PRUN) = <TBD> w: In this state the processor is running, is capable of receiving software commands and can transmit memory dump data and/or housekeeping data in a format selected by command. All memory programming will be done with the instrument in this state. To allow for processor initialization and self test, no software commands should be sent to the instrument for a minimum of <TBD> seconds after the processor has been commanded to run.

High Voltage ON (HVON) = 3.4 w: This is the full operation state of the instrument. While there are a number of data modes/formats that can be selected by command, the power is insensitive to these different formats.

SWEPAM-I nominal and peak power requirements are the same, 3.4watts @ 28 volts.
SWEPAM-I has no heaters or other operating mode that changes the nominal power requirements.
SWEPAM-I autonomy trip current is 0.158 <TBR> Amps after <TBD> Seconds.

NOTE:

THE DATA ABOVE IS FOR INFORMATION AND PLANNING PURPOSES. PAYLOAD INSTRUMENT POWER DATA ARE CONTAINED AND CONTROLLED IN THE CALTEC DOCUMENT ACE-CT-100-40. THIS DOCUMENT SHALL BE CONSULTED FOR CURRENT POWER LEVELS.

FSCM NO. 88898	SIZE A	DWG. NO. 7345-9020
SCALE	DO NOT SCALE PRINT	SHEET 2-15

Figure 2.4.1.1-1 SWEPAM-I Connector Data

Equipment Interface and Test Connector Selection

All SWEPAM-I spacecraft interface connectors meet the requirements of GSFC S-311-P-10. The test connector is a flight certified ITT Cannon MDM style connector.

All SWEPAM-I interface and internal connectors comply with RM level C.

Exceptions to the requirements of paragraph 2.4

The primary power connector (J01) and pyro connector (J03) are the same connector type and contact arrangement. No keying is planned. With the heritage pin out, mismating these cables will cause damage to the low voltage power supply if the pyro fire command was sent and would cause the PSC fuses for SWEPAM-I to open if power was applied to the instrument. The pyros should not fire. The SDT shall determine if the connector location and identification are sufficient to preclude an accidental mismatch.

The SWEPAM-I instrument uses connectors of the types listed below. The connectors on the instrument are supplied by the instrument and the mating connectors are provided by JHU/APL.

CONNECTOR	TYPE	DESCRIPTION	NAME
A1080-J01	311P10B-1P-B-12	9 PIN MALE	POWER
A1080-J02	311P10B-4P-B-12	37 PIN MALE	C&DH
A1080-J03	311P10B-1P-B-12	9 PIN MALE	COVER PYRO
A1080-J04	MDM-15PSB-A174	15 PIN MDM	GSE

FSCM NO. 88898	SIZE A	DWG. NO. 7345-9020
SCALE	DO NOT SCALE PRINT	SHEET 2-16

2.4.2 ACE Spacecraft/Instrument Interface Connectors

2.4.2.1 General

The following guidelines shall be followed for all instrument/sensor connectors which interface with the spacecraft subsystems.

- a) Instrument/sensor power and interface connectors shall be located and spaced so that they can be readily and safely mated and demated during the integration and test phases of the program.
- b) Primary Bus Power feed and return interfaces shall be contained in a separate male connector. In the event that this requirement cannot be met, all power and return interfaces shall be in the same connector.
- c) Multiple connectors shall be of different sizes or shall be uniquely keyed in order to minimize mating errors.
- d) All interface connectors shall be uniquely identified. J-numbers shall be assigned by the instrument/sensor experimenter.
- e) Connector covers shall be provided by the instrument/sensor experimenter for all connectors which do not interface with the spacecraft during flight.
- f) Connectors which use crimped contacts shall have the spare and unused pin locations populated.
- g) Torque requirements for installation of all interface connectors, protective covers, or flight plugs shall be defined by the instrument/sensor experimenter and documented by connector number in this SIIS. Preferred connectors are exempt.

2.4.2.2 Pin Assignments

The instrument/sensor experimenter shall identify pin assignments for all instrument/sensor interfaces with the spacecraft. **Instrument pin assignments are documented in Figure 2.4.2.2-1.** The following are connector pin assignment guidelines:

- a) Redundant wires and connector pins shall be used for all primary bus power inputs and returns.
- b) Pin assignments shall be made in a manner that will reduce signal crosstalk.
- c) Signal and signal returns shall be located on adjacent pins to facilitate wire twisting and shielding.

FSCM NO. 88898	SIZE A	DWG. NO. 7345-9020
SCALE	DO NOT SCALE PRINT	SHEET 2-17

Figure 2.4.2.2-1 SWEPAM-I/Spacraft Interface Connector Pin Assignments

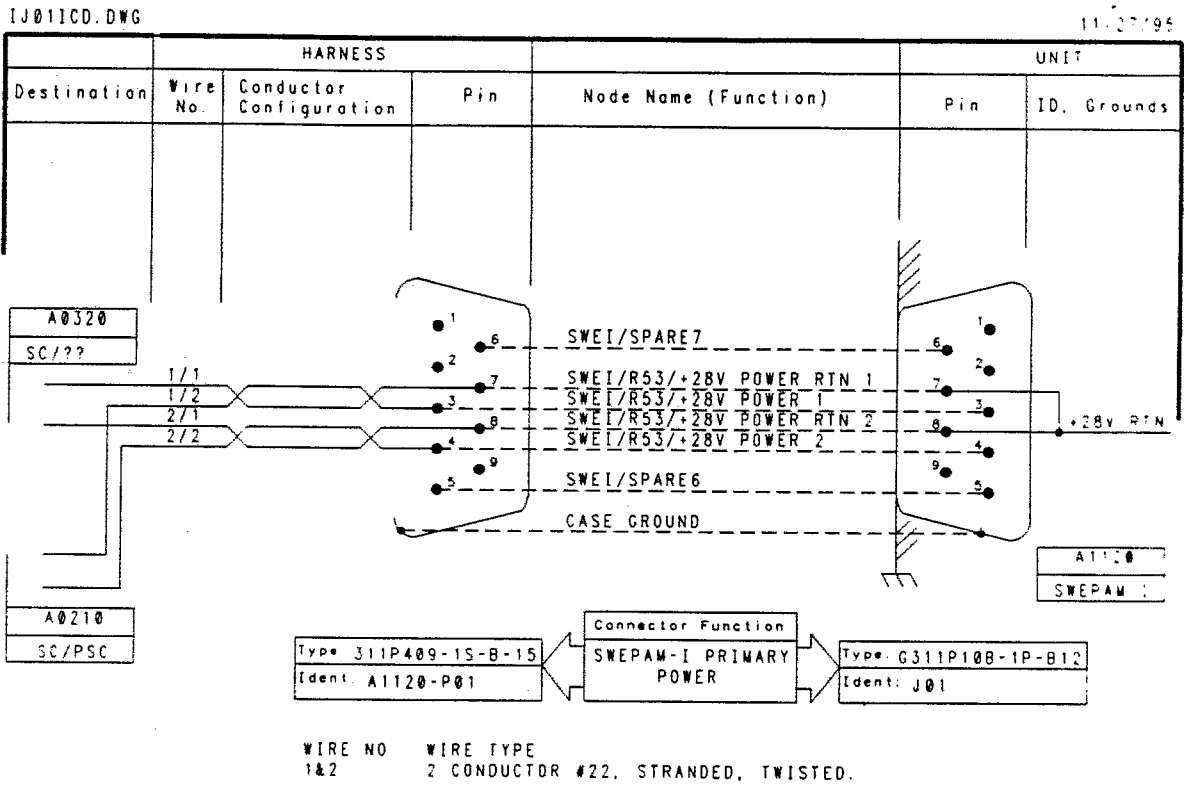

FSCM NO. 88898	SIZE A	DWG. NO. 7345-9020
SCALE	DO NOT SCALE PRINT	SHEET 2-18

Figure 2.4.2.2-1 SWEPAM-I/Spacecraft Interface Connector Pin Assignments
(cont.)

IJ021CD.DWG

02/15/95

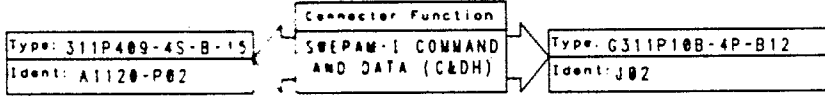
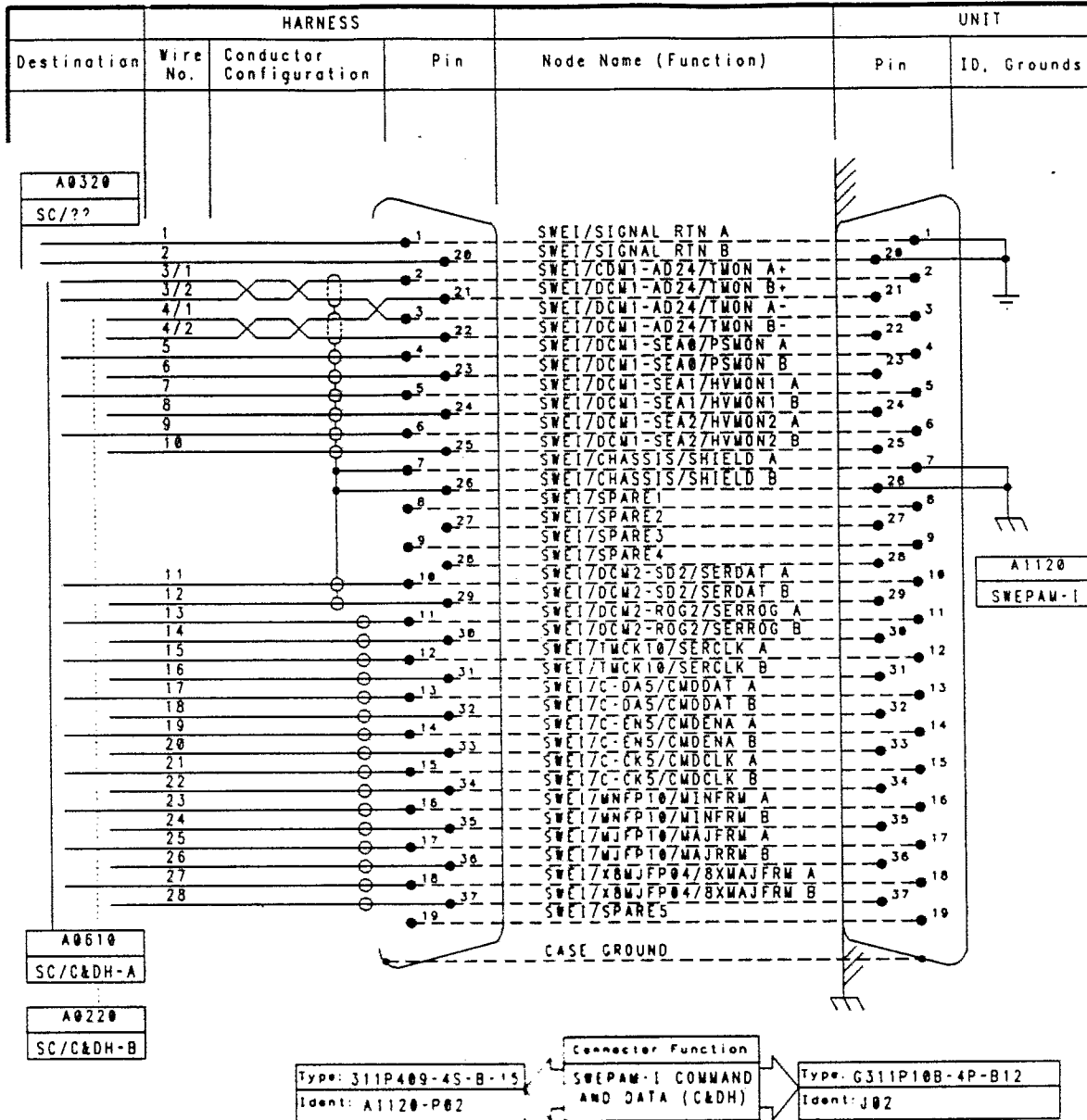

WIRE NO WIRE TYPE

1,2 1 CONDUCTOR #24 STRANDED, INSULATED.

3,4 2 CONDUCTOR #24 STRANDED, SHIELDED, JACKETED

5-28 1 CONDUCTOR #24 STRANDED, SHIELDED, JACKETED.

FSCM NO.	SIZE	DWG. NO.
88898	A	7345-9020
SCALE	DO NOT SCALE PRINT	SHEET 2-19

Figure 2.4.2.2-1 SWEPAM-I/Spacecraft Interface Connector Pin Assignments
(cont.)

IJ03ICD.DWG

02/15/95

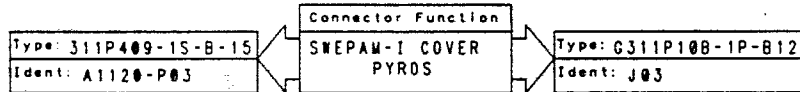
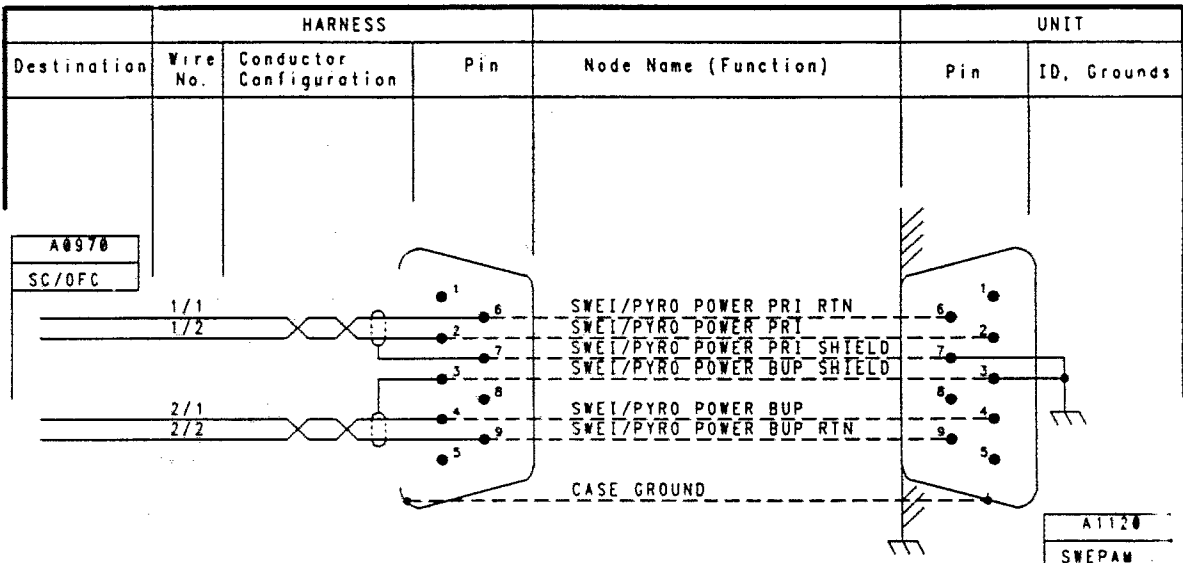

WIRE NO WIRE TYPE
1,2 2 CONDUCTOR #22, STRANDED, SHIELDED, JACKETED.

NOTE: RECOMMEND SHIELDS NOT BE TERMINATED TO THE SHELL OF P03.

FSCM NO. 88898	SIZE A	DWG. NO. 7345-9020
SCALE	DO NOT SCALE PRINT	SHEET 2-20

**Figure 2.4.2.2-1 SWEPAM-I/Spacecraft Interface Connector Pin Assignments
(cont.)**

INTENTIONALLY BLANK

FSCM NO. 88898	SIZE A	DWG. NO. 7345-9020
SCALE	DO NOT SCALE PRINT	SHEET 2-21

**Figure 2.4.2.2-1 SWEPAM-I/Spacecraft Interface Connector Pin Assignments
(cont.)**

INTENTIONALLY BLANK

FSCM NO. 88898	SIZE A	DWG. NO. 7345-9020
SCALE	DO NOT SCALE PRINT	SHEET 2-22

2.4.3 Test and GSE Interface Connectors

Electrical interfaces required by an instrument/sensor for special test purposes, at the Observatory level, shall have a separate connector from those which interface with the spacecraft. **These direct access connectors shall be the responsibility of the instrument/sensor designer and shall be identified in Figure 2.4.3-1 if the connector is necessary for spacecraft integration.** All test connectors shall be readily accessible at the Observatory level. These test connectors should be female. All associated test harnesses shall be removed before flight. These connectors shall be covered before flight and when not in use (green tag item).

2.4.4 Location and Function of "Red Tag" and "Green Tag" Items

Items requiring installation or removal prior to launch shall be identified and the locations specified in Figure 2.4.4-1. Items shall be supplied by the Experimenter and shall be accessible at the Observatory level. "Tag" items shall be color coded as follows: NONFLIGHT -- RED; FLIGHT -- GREEN.

2.4.4.1 Special Connector Plugs

Special plugs such as high voltage enable, disable, etc. may be used to control a component prior to launch. **These plugs shall be identified in Figure 2.4.4.1-1** These plugs shall be color coded as follows: NONFLIGHT -- RED; FLIGHT -- GREEN.

2.4.5 Payload Stimulus and Monitor Interface

When required by the payload, stimulus and monitor interfaces shall be provided for the payload instruments through the spacecraft umbilical connector. **These interfaces shall be identified in Figure 2.4.5-1 and are the responsibility of the instrument/sensor experimenter.** The number of these interfaces is severely limited and will require negotiation with the spacecraft.

All umbilical level interfaces shall be buffered to prevent damage to the spacecraft in the event of problems which may occur on the umbilical lines or within support equipment.

FSCM NO. 88898	SIZE A	DWG. NO. 7345-9020
SCALE	DO NOT SCALE PRINT	SHEET 2-23

Figure 2.4.3-1 SWEPAM-I Test and GSE Interface Connector Information

**Note: This connector does not interface with the spacecraft.
The GSE connector is for the exclusive use of the SWEPAM-I instrument design team.**

IJ04ICD.DWG 11/27/95

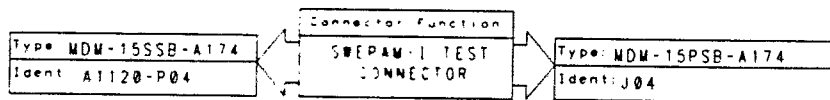
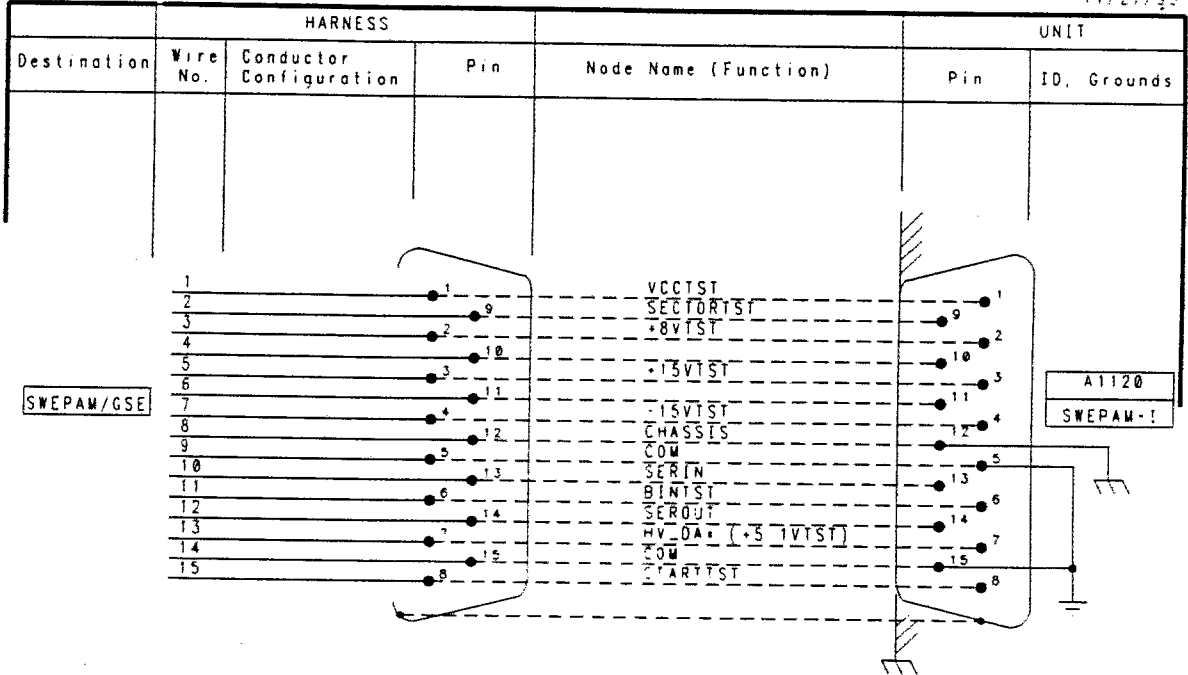

WIRE NO WIRE TYPE
ALL 10COND. #06 STRANDED, INSULATED

NOTES

1. THE FLIGHT CONNECTOR (J04) SHALL BE IN PLACE AT ALL TIMES J04 IS NOT IN USE. WHEN THE COVER IS REMOVED, IT RECEIVES A RED TAG AND REMAINS TEACHERED TO THE INSTRUMENT.

FSCM NO. 88898	SIZE A	DWG. NO. 7345-9020
SCALE	DO NOT SCALE PRINT	SHEET 2-24

Figure 2.4.4-1 Location and Use of SWEPAM-I "Red Tag"/ "Green Tag" Items

Non-Flight Protective Covers "Red Tag Items"

The SWEPAM-I shall be delivered with ESD safe plastic covers installed on all flight interface connectors. If the need should arise for the SDT to install protective covers on the interface connectors, only ESD safe covers shall be used.

Prior to launch the pump-out port and aperture will be sealed and the purge port will be capped to protect the sensor. These are all non-flight covers.

A non-flight high voltage disable plug shall be provided. This non-flight plug replaces the flight plug on the test connector, J04, as needed.

When the flight plug has been removed from the test connector, it shall remain tethered to the instrument and have it's own protective cover installed. This protective cover shall be "red-tagged" to indicate that a non-flight configuration exist either because the high voltage disable plug or ground support equipment has been mated to the test connector.

There will be a non-flight (red-tag) plug that will be installed on the test connector, J04, whenever the instrument is being transported. This plug has provisions to attach a jumper between two eyelets and tie the instruments chassis ground to signal ground. Since the sensor head is at signal ground potential, this effects a connection of the sensor chassis to the box chassis for ESD control.

This same non-flight plug disables high voltage operation. During all test on the spacecraft, this non-flight plug should be replaced by the flight plug. So in summary, the ESD jumper is only installed/removed as part of the spacecraft cable mate/dismate procedures. The jumper come off after the spacecraft connectors are mated and the jumper goes on before the spacecraft cables are disconnected.

Flight Covers and Doors "Green Tag Items"

Prior to installation of the payload shroud during launch preparation, the IDT will need to remove the seals from the pump-out port and aperture, install the light baffle, install the flight aperture cover, assist the SDT in connecting the instrument to the spacecraft purge manifold and the high voltage to the sensors. Connecting the high voltage requires removing a protective cover on the high voltage make/break connector, moving a jumper and then reinstalling the protective cover. This is part of a single integrated procedure. Rather than each piece of this non-flight configuration being "red-tagged" a single red tag will be applied to indicate the procedure must be performed. The procedure will conclude with a count of all the non-flight items and removal of the "red-tag". The instrument shall not be operated after this procedure has been completed unless the non-flight high voltage disable plug is installed on the test connector, J04. A final inspection shall be made before the spacecraft is enshrouded to assure the flight plug is installed on J04.

The SWEPAM-I aperture cover deploys such that it is always within the envelope of the instrument and therefore causing no disturbance to the spacecraft or other instruments.

The locations of the aperture, HV make/break jumper, pump-out port and purge port are identified on the SWEPAM-I mechanical Interface Drawing in appendix A.

FSCM NO. 88898	SIZE A	DWG. NO. 7345-9020
SCALE	DO NOT SCALE PRINT	
	SHEET	2-25

Figure 2.4.4.1-1 SWEPAM-I Special Connectors/Plugs

NOT APPLICABLE

FSCM NO. 88898	SIZE A	DWG. NO. 7345-9020
SCALE	DO NOT SCALE PRINT	SHEET 2-26

Figure 2.4.5-1 Payload Stimulus and Monitor Interfaces with the S/C through the Umbilical Connector

NONE REQUIRED

FSCM NO. 88898	SIZE A	DWG. NO. 7345-9020
SCALE	DO NOT SCALE PRINT	SHEET 2-27

2.5

Spacecraft Command and Data Handling Subsystem

The spacecraft Command and Data Handling (C&DH) Subsystem consists of two C&DH Components, a Power Switching Component, an Ordnance Fire Component, and two data recorders (see Figure 2.5-1 for the C&DH subsystem block diagram). Each C&DH component is part of one of two "strings" of spacecraft components. Each string includes a command receiver, telemetry transmitter, Sun Sensor, and C&DH component. Control of the Power Switching component and Ordnance Fire Component is cross-strapped to both C&DH components. The two Data Recorders are cross-strapped to both strings. Operationally, only one of the strings will be used unless a failure occurs in that string. A failure would be detected by the mission operations center, not autonomously detected onboard. Each instrument must be aware which string is active.

2.5.1

C&DH Component Command Acceptance

Both C&DH components are always capable of executing commands; typically, only one component will be used to execute commands. Each C&DH component receives telecommand frames from the ground. Each telecommand frame contains one or more instrument or spacecraft commands. It is only possible to address a telecommand frame to one of the two C&DH components, therefore only one C&DH component at a time will execute and output uplinked commands. Telecommand frames are checked for errors before any command in the frame is executed. If any error is found, the entire telecommand frame is rejected. An uplink protocol is used to prevent a telecommand frame from being processed if the previous telecommand frame was rejected. Therefore, execution order of a sequence of commands can be guaranteed, both within a telecommand frame and for a command sequence that extends over multiple telecommand frames. In addition to error detection at the telecommand level, individual commands also contain an error detection code. A command will not be executed if an error is detected.

2.5.2

Command Execution - Real-time

A telecommand frame can contain a combination of commands that are to be executed immediately and commands that are to be stored for future execution. Commands that can be executed immediately upon reception by the C&DH component are known as real-time commands.

2.5.3

Command Execution - Stored

Three types of stored commands can be specified: Time Tagged, Autonomy, and Block commands. A Time Tagged command is stored for execution at a specific spacecraft time count. It is stored in C&DH memory with an associated time tag. When the current spacecraft time count matches the stored time tag, the command is executed. Time tagged commands are scanned once a second. An Autonomy command is stored for execution based on the value of a particular byte of housekeeping telemetry. An autonomy command is stored with a rule. The rule contains a pointer to a specific byte of telemetry, and a comparison of that byte of telemetry to a fixed value or range. If the comparison becomes true, the autonomy command associated with the rule is executed. Autonomy rules are evaluated once per second. The rule can be required to be true multiple times before the command is executed. Autonomy commands, including the telemetry byte pointer and comparison value(s), can be reloaded by

FSCM NO. 88898	SIZE A	DWG. NO. 7345-9020
SCALE	DO NOT SCALE PRINT	SHEET 2-28

Figure 2.5-1 C&DH Subsystem Block Diagram

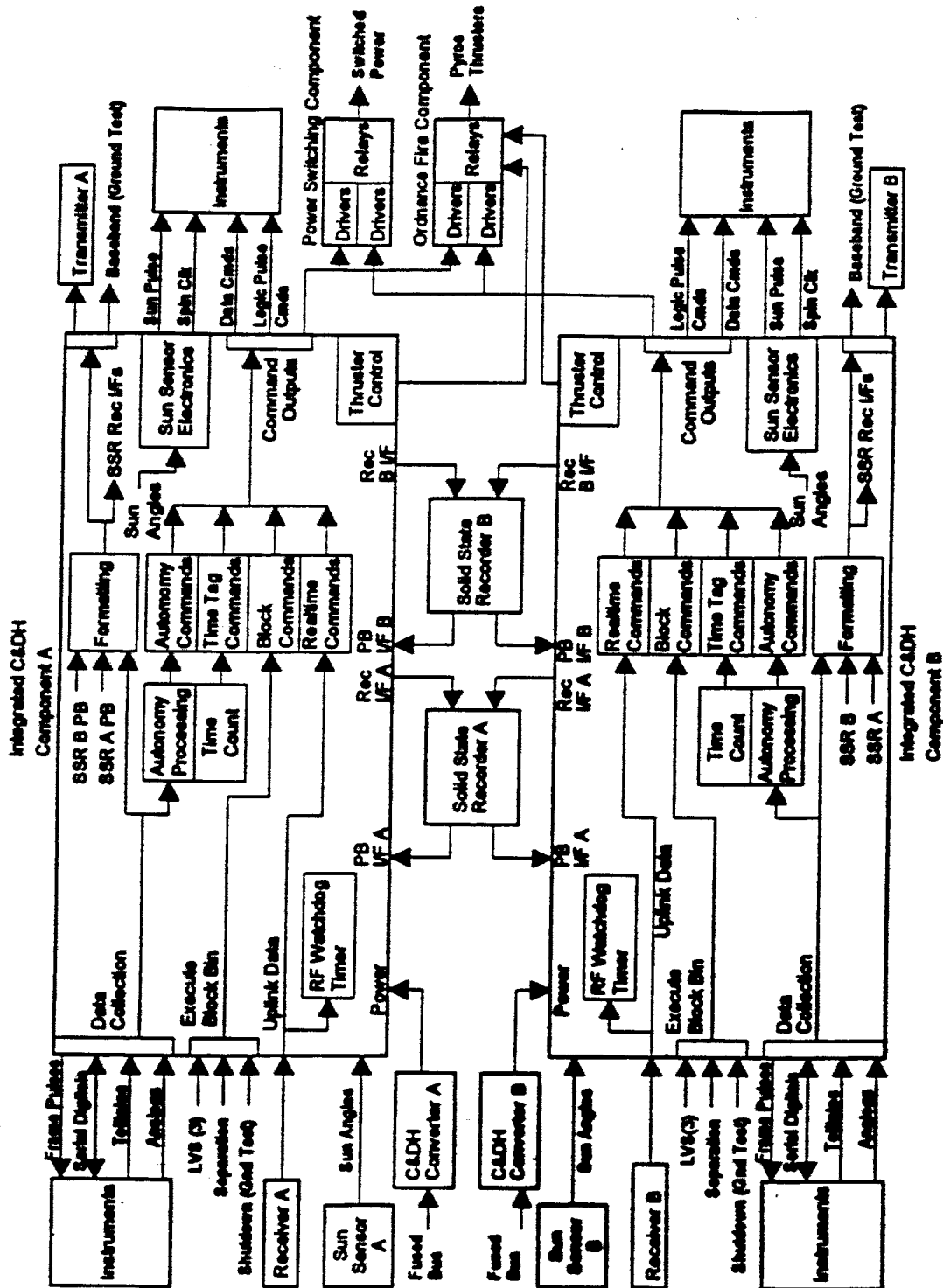

FSCM NO. 88898	SIZE A	DWG. NO. 7345-9020
SCALE	DO NOT SCALE PRINT	
	SHEET	2-29

ground command. Finally, a Block command can be stored as a part of a group of commands. Blocks allow for sequences of greater than one command to be executed based on a single event. Commands in a block are executed based on the execution of a Block Bin Execute command, or in special cases in response to an event such as Low Voltage Sense. A Block Bin Execute command can itself be a real-time, block time tagged, or autonomy command.

2.5.4 C&DH Subsystem Command Interfaces

The C&DH Subsystem provides four types of command interfaces. These are the Logic Pulse, Data, Relay and Remote Relay command interfaces. The Logic Pulse and Data Command interfaces are duplicated on each C&DH Component and the user needs to accommodate the redundant interfaces. Care should be taken with instrument input design, because both command interfaces are powered, in the high impedance off state, throughout the ACE mission. In the case of instruments with largely CMOS circuits, this can mean that parts of the instrument could be powered from sneak paths through diodes to the rails of the input buffers. The recommended first circuit should be used to ensure compatibility with the C&DH components.

2.5.4.1 Logic Pulse Command

The Logic Pulse interface provides a 40-millisecond transistor switch closure to ground. An instrument should always listen to the Logic Pulse interfaces from both C&DH components, although only one is active at a time. The low power circuit suggested for the user makes use of the CD4050 with a small hysteresis feedback resistor. The CD4050 is suggested due to the lack of input diodes to the power rail. A filter is suggested to reduce the interfaces susceptibility to noise.

2.5.4.1.1 Description

The Logic Pulse command provides a 40-millisecond transistor switch closure to ground. A logic pulse timing diagram is shown in Figure 2.5.4.1.1-1.

2.5.4.1.2 Interface

The standard interface is shown in Figure 2.5.4.1.2-1. The instrument shall include a separate interface for each C&DH Component. The components used to implement the interfaces to each of the C&DH Component shall be physically distinct and separate; no single part shall serve both redundant circuits. **Specific instrument logic pulse interface is shown in Figure 2.5.4.1.2-2.**

2.5.4.2 Data Command

The Data Command provides variable length data to the instruments. An output data length from 8 to 4096 bits in multiples of 8 bits is acceptable. Note: no header or checksum is added to the data by the C&DH component; the C&DH component acts as a bent-pipe. The gated output clock sets the data rate at $1200 \pm 3\%$ bits per second. Consecutive data command outputs may follow as close as one millisecond, longer time intervals are possible. An instrument should always listen to the data command interfaces from both of the C&DH components although only one is active at a time.

FSCM NO. 88898	SIZE A	DWG. NO. 7345-9020
SCALE	DO NOT SCALE PRINT	SHEET 2-30

Figure 2.5.4.1.1-1 Logic Pulse Command Timing

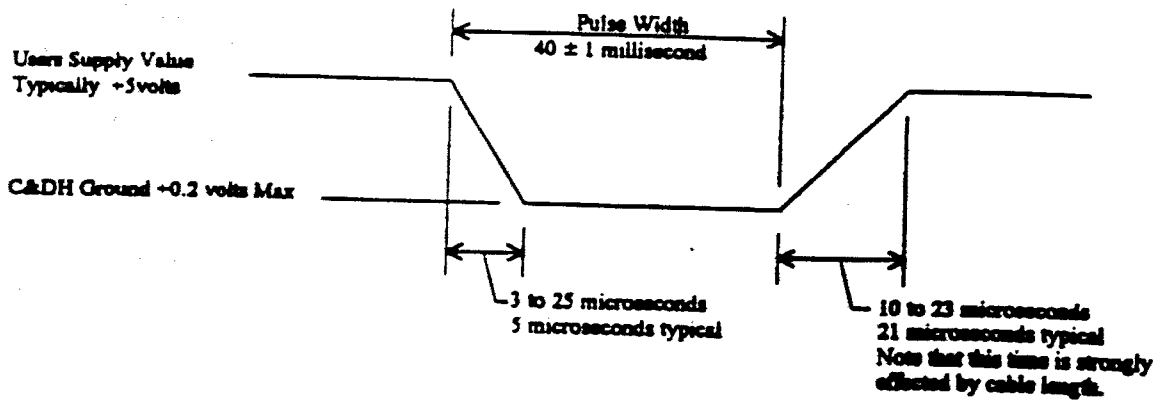

FSCM NO. 88898	SIZE A	DWG. NO. 7345-9020
SCALE	DO NOT SCALE PRINT	SHEET 2-31

Figure 2.5.4.1.2-1 Logic Pulse Interface

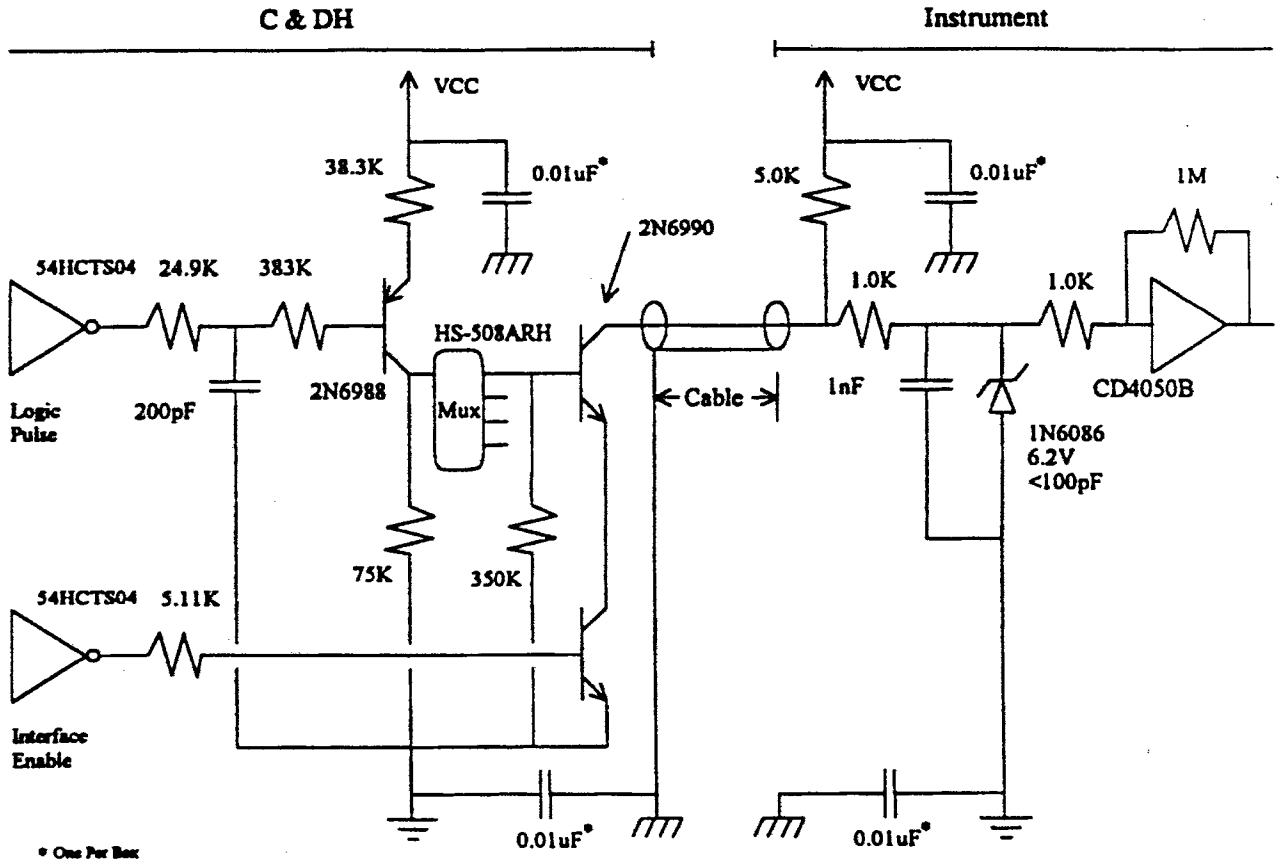

FSCM NO. 88898	SIZE A	DWG. NO. 7345-9020
SCALE	DO NOT SCALE PRINT	SHEET 2-32

Figure 2.5.4.1.2-2 SWEPAM-I Logic Pulse Interface

THE SWEPAM-I INSTRUMENT REQUIRES NO LOGIC PULSE INTERFACE

FSCM NO. 88898	SIZE A	DWG. NO. 7345-9020
SCALE	DO NOT SCALE PRINT	SHEET 2-33

The data are conveyed across a three signal interface (Enable, Clock and Data). The timing diagram of Figure 2.5.4.2-1 depicts the signals' relationships. The gated clock has a 50% duty cycle when present; the gated clock is only present when the data are actually being sent. The enable is an active low signal that will transition at least one quarter of a bit time before the clock transitions from high to low. Data is valid on the falling edge of the clock and will change on the rising edge. The enable will be removed with the rising edge of the clock on the last data bit transferred.

Memory load will be accomplished over the data interface using a maximum of 4096 bits in increments of 8 bits. Memory loads using a data command are treated identically by the C&DH component as any other type of data command.

2.5.4.2.1 Interface

The first level circuit diagram of Figure 2.5.4.2.1-1 is the suggested data interface. An advantage to this circuit is the high level reference is user supplied. Both interfaces depict a single C&DH component data command interface with the instrument. The instrument must make provision to accept these interfaces. Input buffers to one C&DH component should not share the same package with buffers to the second C&DH component. An instrument should not wired "or-ed" together the buffered data, clock and enable lines from one C&DH component with the equivalent signals from the other C&DH components. **Specific instrument data command interface is shown in Figure 2.5.4.2.1-2.**

2.5.4.3 Relay Command (Switched Power)

2.5.4.3.1 Description

Relay Commands control switched power for the spacecraft. The relays used for switching the power are grouped into two categories, Ordnance and Power Switching. The Ordnance Fire Component is responsible for switching power to the Ordnance on board the spacecraft. The Power Switching Component supplies switched power to the users on the spacecraft.

Latching relays are not redundant for these interfaces. In general, there are multiple contacts in each relay. Each relay contains two coils. One of the coils is controlled by C&DH component A and the other coil is controlled by C&DH component B. For relays switching power, the harness will contain one more wire than is required to carry the power to the user. Latching relays will utilize one contact as a position indicator. The state of the indicator is telemetered to the ground.

FSCM NO. 88898	SIZE A	DWG. NO. 7345-9020
SCALE	DO NOT SCALE PRINT	
	SHEET	2-34

Figure 2.5.4.2-1 Data Command Timing

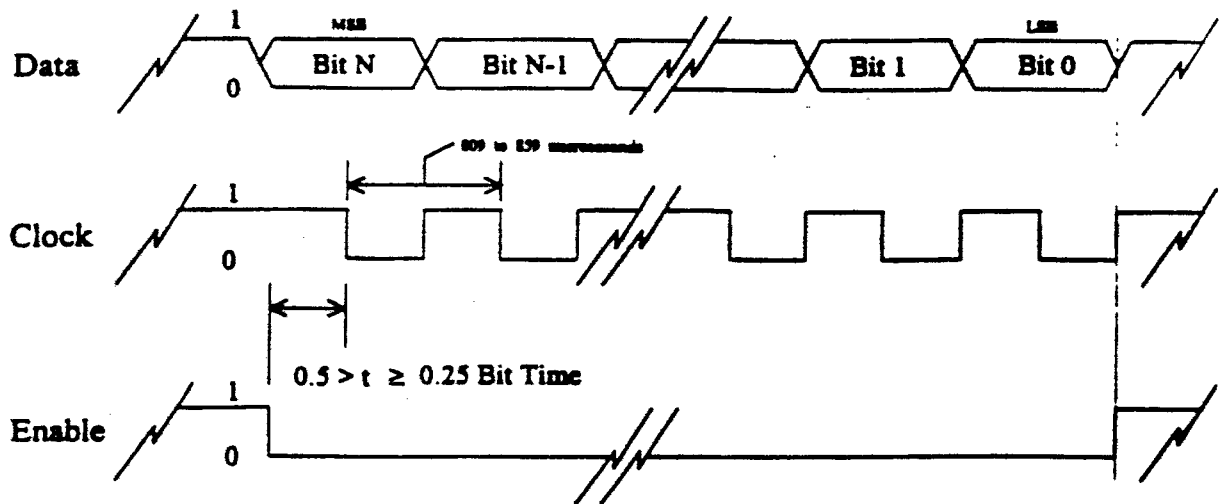

FSCM NO.	SIZE	DWG. NO.
88898	A	7345-9020
SCALE	DO NOT SCALE PRINT	SHEET 2-35

Figure 2.5.4.2.1-1 Data Command Interface

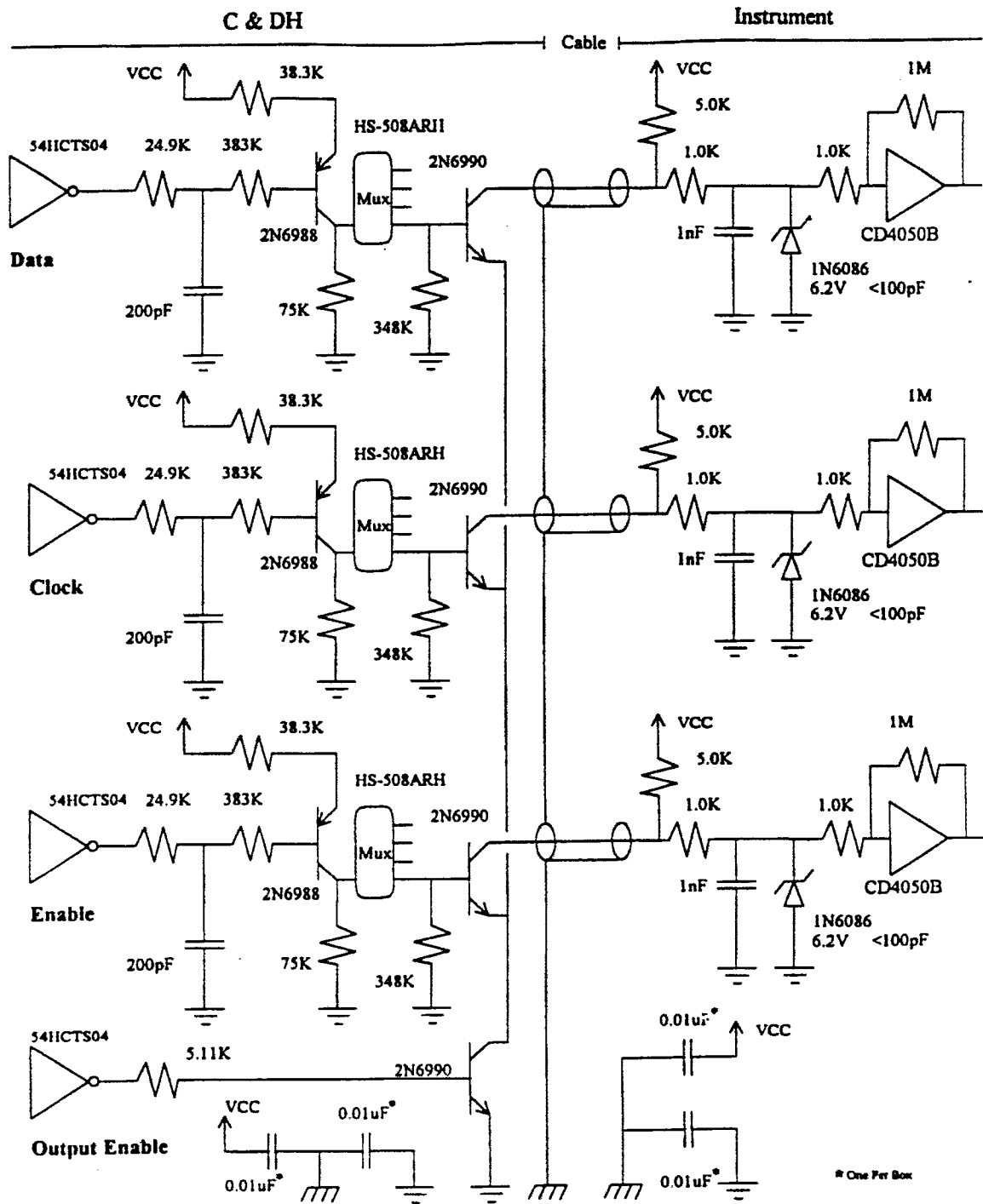

FSCM NO.	SIZE	DWG. NO.
88898	A	7345-9020
SCALE	DO NOT SCALE PRINT	SHEET 2-36

Figure 2.5.4.2.1-2 SWEPAM-I Data Command Interface

Description

The spacecraft shall provide the SWEPAM-I with a redundant Data Command interface which meets the specification defined in paragraph 2.5.4.2. The SWEPAM-I will use this interface to receive all real time commands, spacecraft stored commands, autonomy commands and memory loads. All SWEPAM-I commands are 24 bits in length. SWEPAM-I requires the ENABLE signal to return to the inactive state for at least one clock cycle between 24 bit command words.

Memory loads shall be a variable length sequence of load control and load data bytes. Most memory loads will require more than one command frame. The enable signal shall not return to the inactive state except at the end of a command frame.

When OFF, the SWEPAM-I is insensitive to the logic states presented on the ENABLE, DATA and CLOCK signal lines.

Interface Circuit

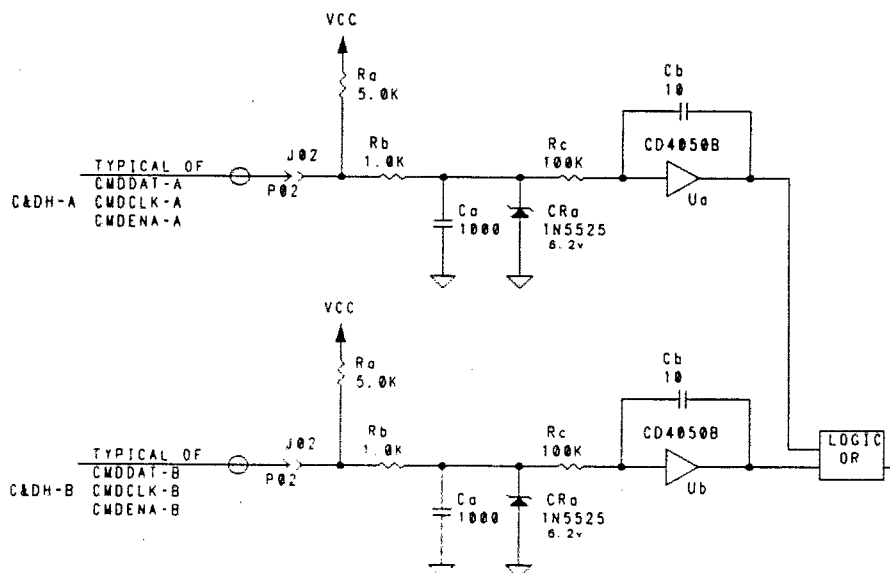

MNEMONIC DESCRIPTION
 CMDDAT = COMMAND DATA
 CMDCLK = COMMAND CLOCK
 CMDENA = COMMAND ENABLE GATE

COMPONENTS
 Ra = RNC55H5001FS
 Rb = RNC55H1001FS
 Rc = RNC50H1003FS
 Ca = M39014/05-2237
 Cb = CCR75CG100JS
 CRa = JANTX1N5525B-1
 Ua, Ub = CD4050BKMSH

NOTES
 1 THE CD4050 BUFFERS FOR THE REDUNDANT INTERFACE WILL BE FROM A SECOND DEVICE. NEITHER OF THESE TWO DEVICES ARE SHARED BY THE DATA INTERFACE

FSCM NO. 88898	SIZE A	DWG. NO. 7345-9020
SCALE	DO NOT SCALE PRINT	SHEET 2-37

2.5.4.3.2 Interface

The following illustrates the typical power switching relay interface (see Figure 2.3-1). Relays are redundant at the coil level. The wires to the user will contain one more than necessary to carry the current. The current in the return line is sensed with a current sensing resistor on a spacecraft terminal board. **The instrument power relay interface is shown in Figure 2.5.4.3.2-1.**

2.5.4.4 Relay Command (Ordnance)

2.5.4.4.1 Interface

The following illustrates a typical Ordnance Fire Interface (Figure 2.5.4.4.1-1). Notice the enable relay in series with the actual fire relay. The Ordnance Fire Component also provides 100 ohm resistors to ground in the safe position of the fire relay. The resistors in series with each ordnance is to current limit the ordnance line. Instruments shall specify minimum all fire current, recommended all fire current, maximum all fire current, and maximum no fire current.

The diagram in Figure 2.5.4.4.1-1 illustrates the wiring for the Ordnance used by a user with two redundant pyros. The Ordnance Fire Component uses one enable relay for multiple pyro, in this case two "A" and "B." Each pyro has a primary and backup side. Both primary and back-up pyros may be fired simultaneously, if specified in Figure 2.5.4.4.1-2. Not shown are the relay coils that are driven from each C&DH component. The exact ordnance relay configuration for each instrument is documented in the instrument SIIS. The requirements of Eastern Range Requirement Document (127-1) will apply except as noted in the SIIS. Pyrotechnic circuits shall be isolated from all other instrument circuits. A separate pyro connector shall be used. **The instrument ordnance fire interface is shown in Figure 2.5.4.4.1-2.**

2.5.4.4.1.1 Pyrotechnic Firing Voltage

Pyrotechnic firing voltage will be between 19 and 27 VDC; no fuses will be used in the pyrotechnic firing circuit. The pyrotechnic firing bus will be redundant.

2.5.4.4.1.2 Firing Circuitry

Firing of pyrotechnics is the responsibility of the ACE spacecraft. Each firing circuit shall be separately switched and consist of a shielded, twisted drive/return line pair. Firing of pyrotechnics shall require separate enable sequence and fire commands.

2.5.4.4.1.3 Pyrotechnic Safety Short and Arm Plugs

Each pyrotechnic device, when practical, shall have a shorting device at the ordnance element which is accessible without disassembly of the instrument/sensor at the Observatory level. The spacecraft will have pyrotechnic arming plugs that will be installed prior to launch. **See Figure 2.5.4.4.1-2**

FSCM NO. 88898	SIZE A	DWG. NO. 7345-9020
SCALE	DO NOT SCALE PRINT	SHEET 2-38

Figure 2.5.4.3.2-1 SWEPAM-I Power relay interfaces

Switched Power Interface

The spacecraft shall provide the SWEPAM-I with a single Switched Power Relay Command interface to power the instrument. The relay circuit diagram follows:

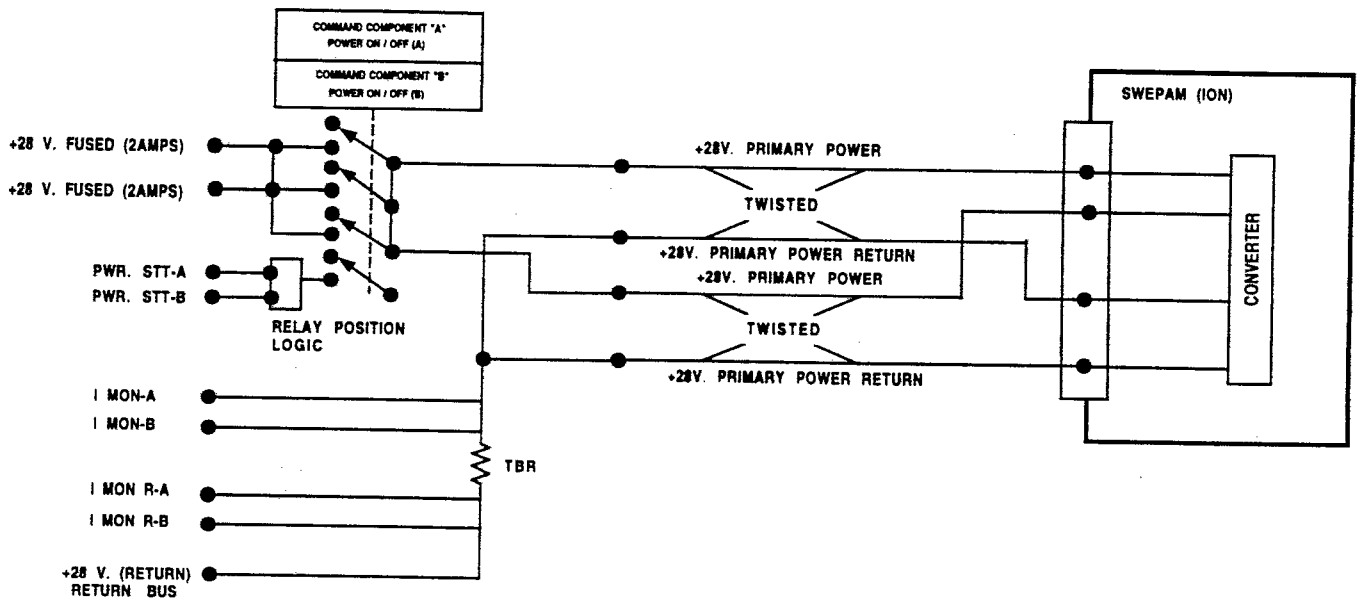

FSCM NO. 88898	SIZE A	DWG. NO. 7345-9020
SCALE	DO NOT SCALE PRINT	SHEET 2-39

Figure 2.5.4.4.1-1 Typical Ordnance Fire Control

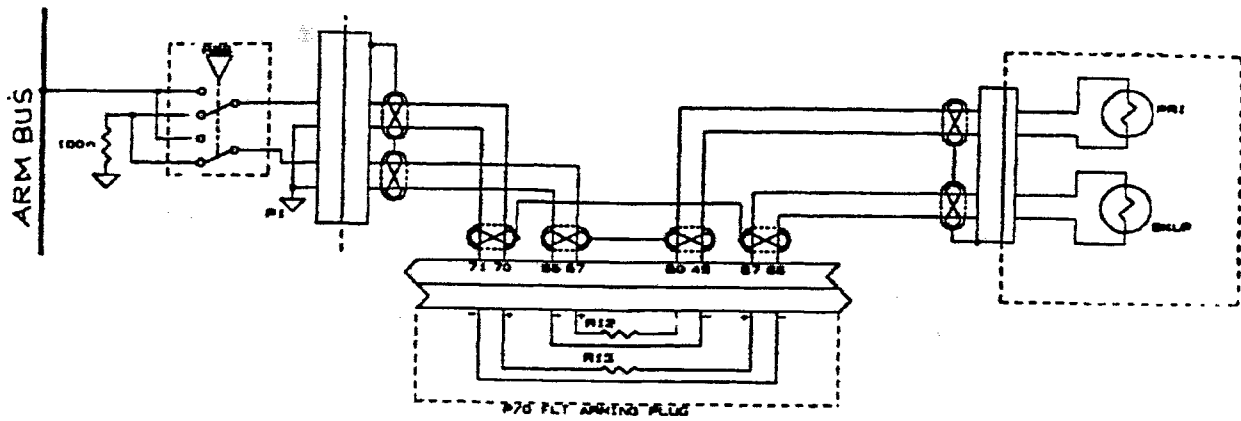

FSCM NO. 88898	SIZE A	DWG. NO. 7345-9020
SCALE	DO NOT SCALE PRINT	SHEET 2-40

Figure 2.5.4.4.1-2 SWEPAM-I Ordnance Fire Interface

Description

The SWEPAM-I uses two pyro actuators to release the single aperture cover mechanism. The initiation of either pyro is normally sufficient but the second pyro is for redundancy. The spacecraft can have the option to fire the pyros concurrently or independently. The pyro interface is on a dedicated connector (J03). The pyro circuits are isolated from all other circuits. The SWEPAM-I uses a <TBD> shorting device at the ordnance elements which is accessible without disassembly of the instrument.

Interface Circuit

The shield termination configuration for J03 is as shown in figure 2.4.2.2-1. For consistency with the SWEPAM-E instrument and to avoid confusion, the IDT recommends that the pyro shield not be connected to the shell of J03 of the SWEPAM-I instrument. To prevent the loss of this isolation, J03 and its shields shall not be allowed to come into contact with the sensor assembly housing. Only when the spacecraft C&DH interface is mated, is the sensor assembly grounded to the spacecraft.

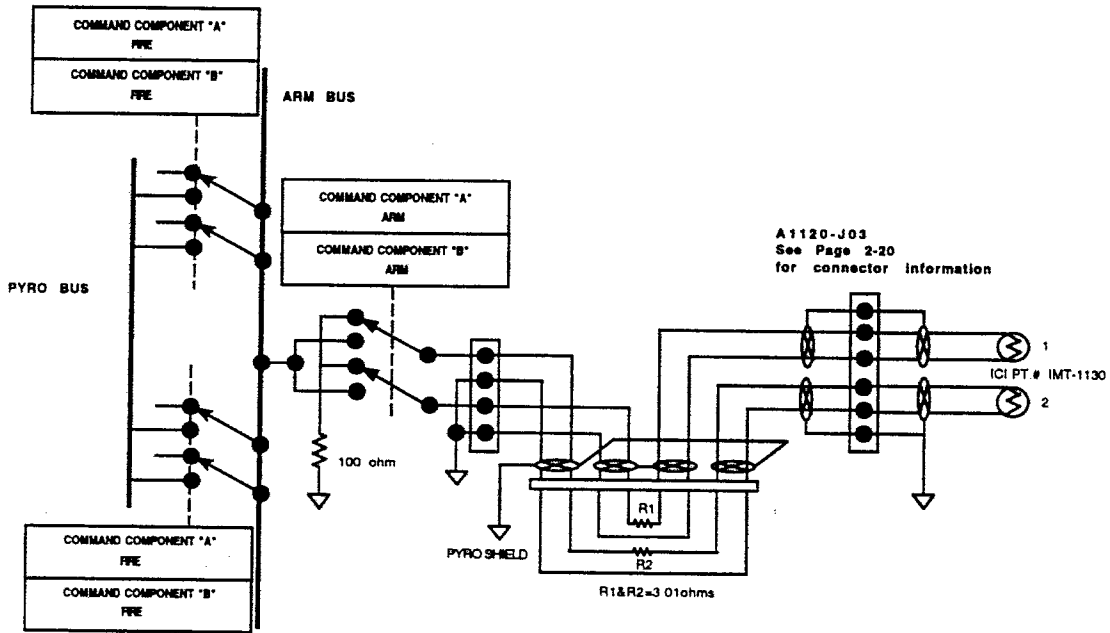

Pyro Characteristics

Pyro Type	ICI P/N IMT1130
Bridgewire	1.0 Ohms ±0.2 Ohms
NFI	1.0 amp / 5 min.
Min Fire	4.0 Amps/10 msec.
Max Fire	10 Amps

FSCM NO. 88898	SIZE A	DWG. NO. 7345-9020
SCALE	DO NOT SCALE PRINT	SHEET 2-41

2.5.4.4.1.4 Pyrotechnic Circuit Shields

The pyrotechnic firing circuit within each instrument/sensor shall be continuously shielded from the ordnance device to the interface connector. The shields shall not be used as intentional current-carrying conductors. The shields shall be grounded to the structure at multiple points.

2.5.4.5 Remote Relay Command

Remote Relay commands provide a pulsed +28 V signal or a pulsed ground signal used for switching relays in instrument packages. The pulse can have a selectable duration of 20, 40, 60, or 80 milliseconds. The remote relay command is implemented with non-latching relays in the spacecraft power switching component. **The exact interface and configuration of the remote relay command, if required, is documented in Figure 2.5.4.5-1.**

2.6 SPACECRAFT C&DH SUBSYSTEM - DATA HANDLING PORTION

Each C&DH Component includes data handling functions. Each C&DH Component collects digital science and housekeeping data, collects and digitizes analog data, and forms a composite serial data stream made up of minor and major frames. A major frame is 16 seconds long and consists of 16 minor frames. Each minor frame makes up the data field of a CCSDS compatible packet, and each packet makes up the data field of a Virtual Channel Data Unit (VCDU), which is the format to be compatible with NASA's ground data system.

Each C&DH Component can connect to instruments with several types of standard telemetry interfaces. These interfaces are serial digital (for science, housekeeping, and memory dump); digital telltale; 0 to +5 V Analog single ended; 0-50 mV differential; and temperature sensor. The instruments need to replicate each telemetry interface that it uses to each C&DH Component.

2.6.1 Data Handling Component Interfaces

The number of each interface type that can be provided to each instrument is limited, and must be negotiated.

2.6.1.1 Serial Digital - Science, Housekeeping, and Memory Dump

2.6.1.1.1 Description

A serial digital interface is used to collect a fixed amount of serial digital data at a periodic interval from each instrument. Data collection will occur in exactly the same spot and will be the same length in any minor frame. Each C&DH component can limit check telemetry data, and execute a command if an out-of-limit condition is detected. The instrument data can be limit checked by a C&DH Component only if the data is in a fixed location in the spacecraft minor frame. Each instrument has been allocated a single serial digital interface per C&DH component.

FSCM NO. 88898	SIZE A	DWG. NO. 7345-9020
SCALE	DO NOT SCALE PRINT	SHEET 2-42

Figure 2.5.4.5-1 SWEPAM-I Remote Relay Command Interface

NOT APPLICABLE

FSCM NO. 88898	SIZE A	DWG. NO. 7345-9020
SCALE	DO NOT SCALE PRINT	SHEET 2-43

Instruments will not be provided with a separate interface for memory dumps. If an instrument needs to dump memory contents, it should replace its normal allocation of science data with dump data. Typically, a command to the instrument would place it in the dump mode for a fixed number of major frames. Science and dump data should be formatted so that the ground decommutation process can detect which type of data is present. Typically, data is output most significant bit first.

Figure 2.6.1.1.1-1 shows the bit allocation for each payload instrument/sensor, and the SSS DPU.

2.6.1.1.2 Interface

Each C&DH Component provides each instrument with the following signals:

- a) Minor Frame Pulse - an active high pulse at the start of every minor frame
- b) Major Frame Pulse - an active high pulse at the start of every major frame, also called 1xMajor Frame Pulse
- c) Clock - a continuous clock at 10,956 Hertz. Exactly 10,956 clock pulses will be generated between minor frame pulses.
- d) Read Out Gate (ROG) - an active high envelope indicating when instruments should output serial data in response to the Clock

In addition, each C&DH Component will provide the following signals only to those instruments that need them:

- a) 2xMajor Frame Pulse - an active high pulse at the start of every other major frame.
- b) 4xMajor Frame Pulse - an active high pulse at the start of every fourth major frame.
- c) 8xMajor Frame Pulse - an active high pulse at the start of every eighth major frame.

In response to these signals, the instrument will output serial data over the Data line with the falling edge of the Clock signal. The first circuit interface is shown in Figure 2.6.1.1.2-1. **The instrument specific interface is shown in figure 2.6.1.1.2-2.** This interface must be duplicated to each C&DH Component. (The instrument must generate a DH select bit in order to select one of the interfaces. Typically an instrument would use a data command to generate the select bit to select the active side.) **Instruments shall provide information on the method used to select the active data interface. This data shall be provided in Figure 2.6.1.1.2-3.** The components used to implement the interface to each C&DH shall be physically distinct and separate; no single component shall serve both redundant interfaces. Interface timing is shown in Figure 2.6.1.1.2-4.

FSCM NO. 88898	SIZE A	DWG. NO. 7345-9020
SCALE	DO NOT SCALE PRINT	SHEET 2-44

Figure 2.6.1.1.1-1 Downlink Bit Allocation for Each Payload Instrument/Sensor

Payload Serial Digital Channel Allocations Per Minor Frame

Instrument	Science Format bits (1)	RTSW Format	Total bits Read out by C&DH
CRIS	464		464
SIS	1992		1992
ULEIS	1000		1000
EPAM	168	168	168
MAG	304	48	304
SWEPAM Ion	544	168	712
SWEPAM Electron	456		456
S ³ DPU	1624		1624
TOTAL	6552	384	6552

(1) Instrument bit stream includes instrument housekeeping and science data.

FSCM NO. 88898	SIZE A	DWG. NO. 7345-9020
SCALE	DO NOT SCALE PRINT	SHEET 2-45

Figure 2.6.1.1.2-1 Serial Digital Interface

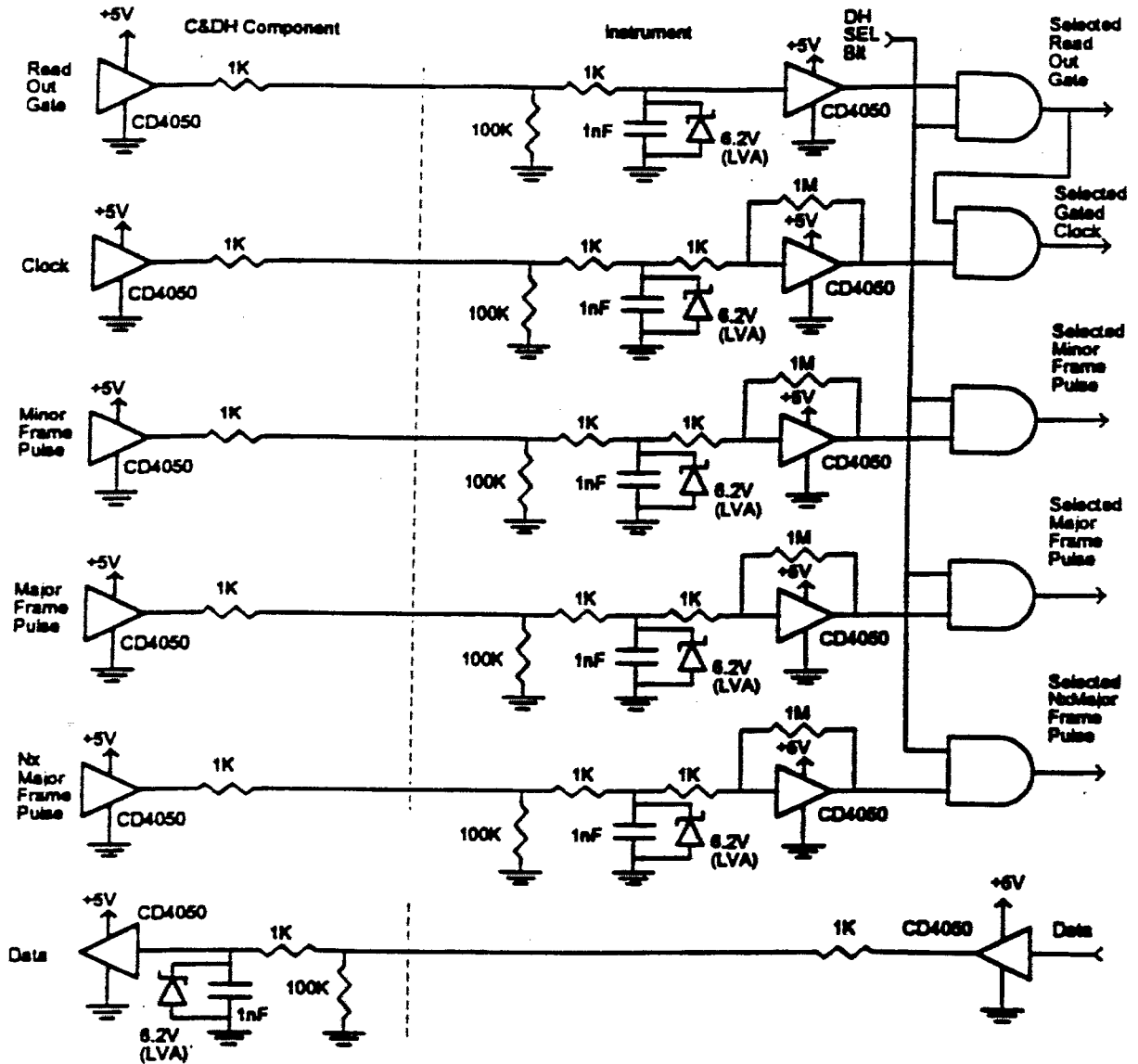

FSCM NO.	SIZE	DWG. NO.
88898	A	7345-9020
SCALE	DO NOT SCALE PRINT	SHEET 2-46

Figure 2.6.1.1.2-2 SWEPAM-I Science, Housekeeping, and Memory Dump Digital Interface (Serial Digital Interface)

Description

The SWEPAM-I will use a single redundant serial data interface to transmit all science, housekeeping (excluding the analog monitors per paragraph 2.6.1.4 and temperatures per paragraph 2.6.1.5) and memory dump data. The SWEPAM-I data format will include a format identifier once per major frame. Any data values which must be limit checked by the spacecraft (none currently defined) will be at the same location in every minor frame.

Interface Circuit

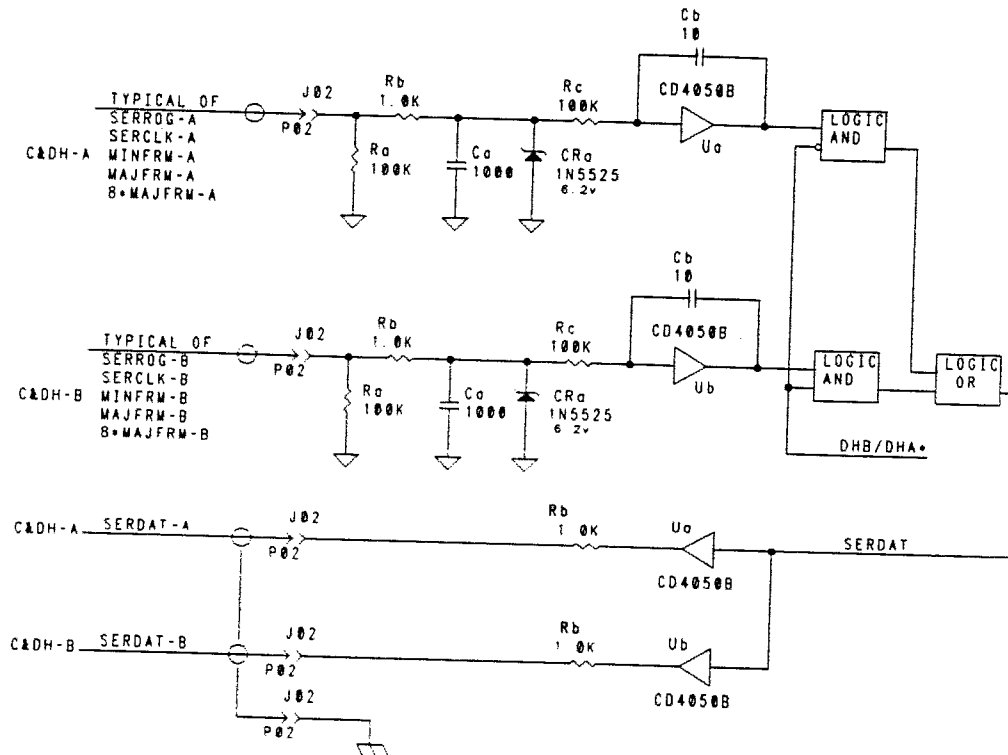

MNEMONIC DESCRIPTION
 SERDAT = SERIAL DATA
 SERROG = SERIAL DATA READ OUT GATE
 SERCLK = SERIAL DATA CLOCK
 MINFRM = MINOR FRAME PULSE
 MAJFRM = MAJOR FRAME PULSE
 B*MAJFRM = B: MAJOR FRAME PULSE

COMPONENTS
 Ra = RNC50H1003FS
 Rb = RNC55H1001FS
 Rc = RNC50H1003FS
 Ca = M39014/05-2237
 Cb = CCR75CG100JS
 CRa = JAN1XV1N5525B-1
 Ua, Ub = CD4050BKMSH

NOTES
 1. THE CD4050 BUFFERS FOR THE REDUNDANT INTERFACE WILL BE FROM A SECOND DEVICE. NEITHER OF THESE TWO DEVICES ARE SHARED BY THE COMMAND INTERFACE

FSCM NO. 88898	SIZE A	DWG. NO. 7345-9020
SCALE	DO NOT SCALE PRINT	SHEET 2-47

Figure 2.6.1.1.2-3 SWEPAM-I Method Used to Select Active Data Channel

The SWEPAM-I decodes a special serial data command to select one of the two serial data interfaces, A or B. Interface A is the default. The default or last commanded state of this selection is valid even should the SWEPAM-I processor be reset by a watchdog time-out. Also see the block diagrams at figures 2.2.2.4-1 and 2.6.1.1.2.-1.

FSCM NO. 88898	SIZE A	DWG. NO. 7345-9020
SCALE	DO NOT SCALE PRINT	SHEET 2-48

Figure 2.6.1.1.2-4 Serial Digital Interface Timing

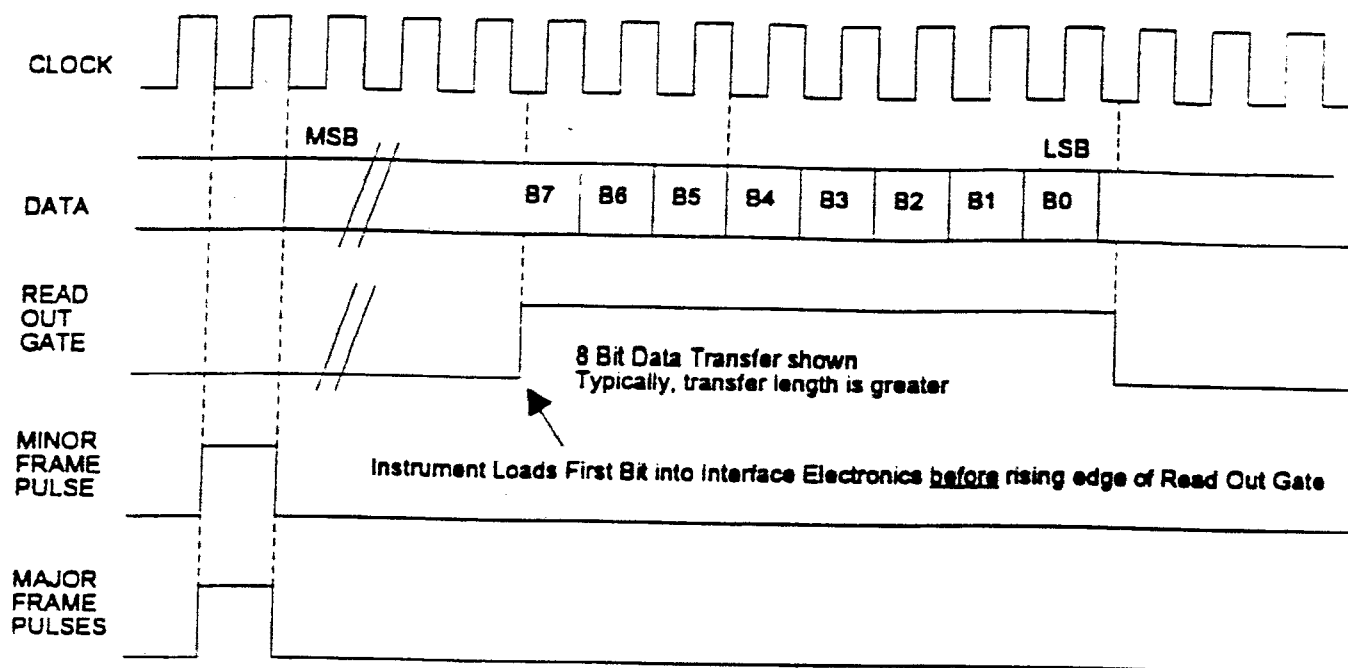

Notes:

1. Instrument initiates load of first bit before the rising edge of Read Out Gate (after Minor Frame Pulse).
2. After first data bit, instrument loads next data bit on falling edge of clock, C&DH Component reads on rising edge of clock. The data must be stable 1/4 bit time before the rising edge of the clock signal.
3. Major Frame pulses (1x, 2x, and 8x) not present every minor frame.
4. Low= logic 0 = Ground; High = logic 1 = 5V.
5. Minor and Major Frame Pulses may be delayed from the clock edges by up to 5 microseconds.

COLLECTION OF SCIENCE DATA

Start - 2472 Bits from Minor Frame Pulse (first bit in minor frame is bit 0)
Duration - 712

FSCM NO.	SIZE	DWG. NO.
88898	A	7345-9020
SCALE	DO NOT SCALE PRINT	SHEET 2-49

2.6.1.2 Digital Telltales

2.6.1.2.1 Description

The digital telltale interface will be used to sample the state of a two state device (such as a switch) in an instrument. It is only appropriate to use a digital telltale interface if the state of the device must be sampled when the instrument is turned off (otherwise the instrument could embed the telltale in its serial telemetry stream).

2.6.1.2.2 Interface

Two types of digital telltale interfaces are available. If +5V is available in the device to be sampled, the telltale can be buffered with a CD4050 device. If the telltale is derived from a switch, and +5V is not available to establish two levels, the switch should connect to signal ground in one state and be open in the other state. The two interfaces are shown in Figure 2.6.1.2.2.-1. **The instrument specific interface is shown in Figure 2.6.1.2.2-2.**

2.6.1.3 0-5V Single Ended Analog Interface

2.6.1.3.1 Description

The interface is used to sample and digitize voltages which have been conditioned to be within a 0 to 5V range. Note that if the output of a +5V DC-DC converter is to be sampled, the telemetry point should be a resistively divided version of the converter output so that a converter output over-voltage can be sensed. Subcommutated interfaces will be supported but must be synchronized to the 2x or the 8x major frame pulse. Note: users should not assume that the least significant bit is free from noise.

2.6.1.3.2 Interface

The first circuit interface is shown in Figure 2.6.1.3.2-1. Note: The op amp used to buffer the single-ended voltage should be capable of maintaining its output voltage if the output to one C&DH component is grounded. Power supply voltages can use two resistive dividers instead of an op amp. **The instrument specific interface is shown in Figure 2.6.1.3.2-2.**

2.6.1.4 0 to +50mV Differential Analog Interface

2.6.1.4.1 Description

The interface is typically used to sample the voltage across a current sensing resistor.

FSCM NO. 88898	SIZE A	DWG. NO. 7345-9020
SCALE	DO NOT SCALE PRINT	SHEET 2-50

Figure 2.6.1.2.2-1 Digital Telltale Interface

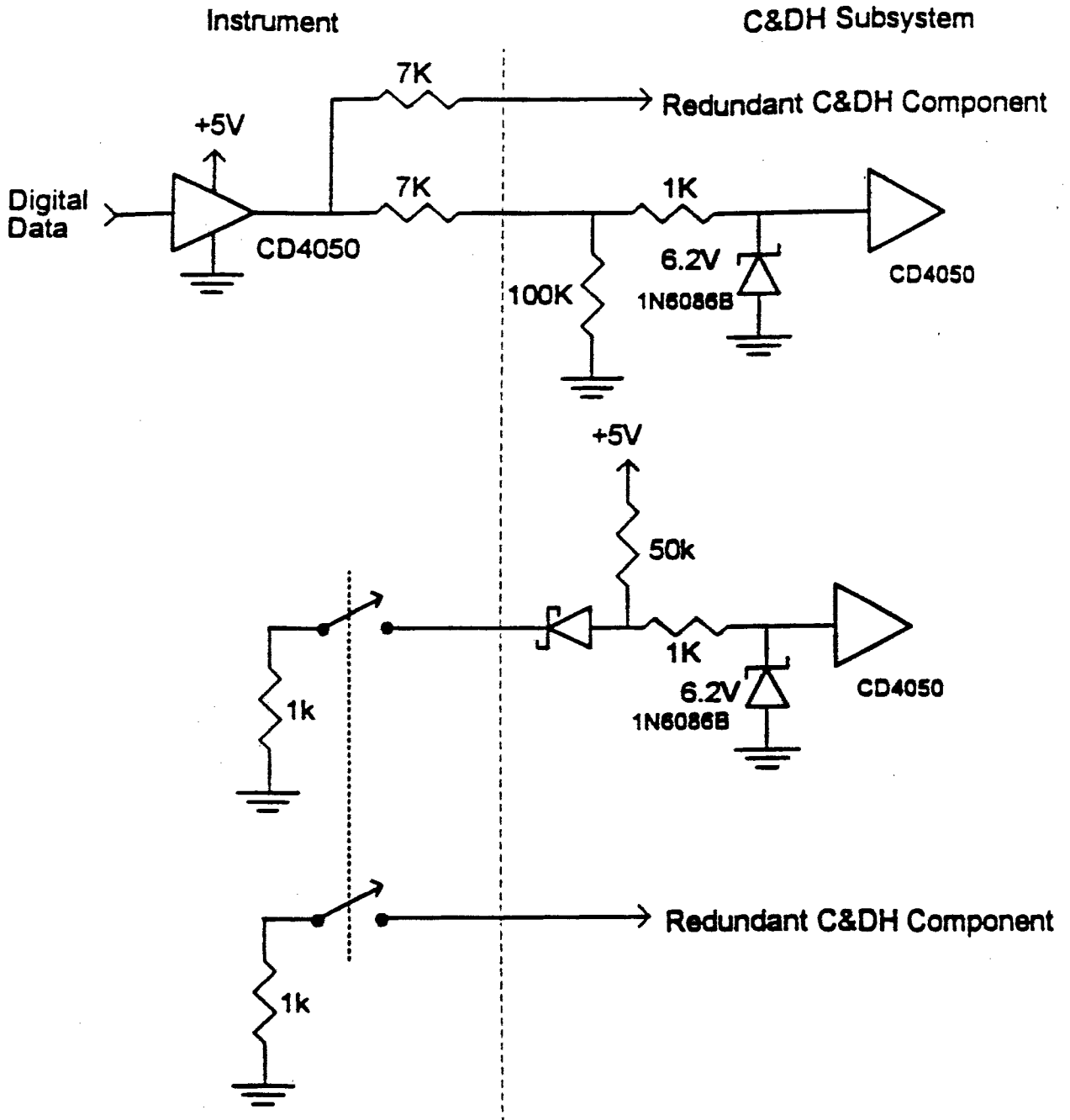

FSCM NO.	SIZE	DWG. NO.
88898	A	7345-9020
SCALE	DO NOT SCALE PRINT	SHEET 2-51

Figure 2.6.1.2.2-2 SWEPAM-I Digital Telltale Interface

The SWEPAM-I instrument does not utilize the digital telltale interface.

FSCM NO. 88898	SIZE A	DWG. NO. 7345-9020
SCALE	DO NOT SCALE PRINT	SHEET 2-52

Figure 2.6.1.3.2-1 Single Ended Analog 0-5V Interface

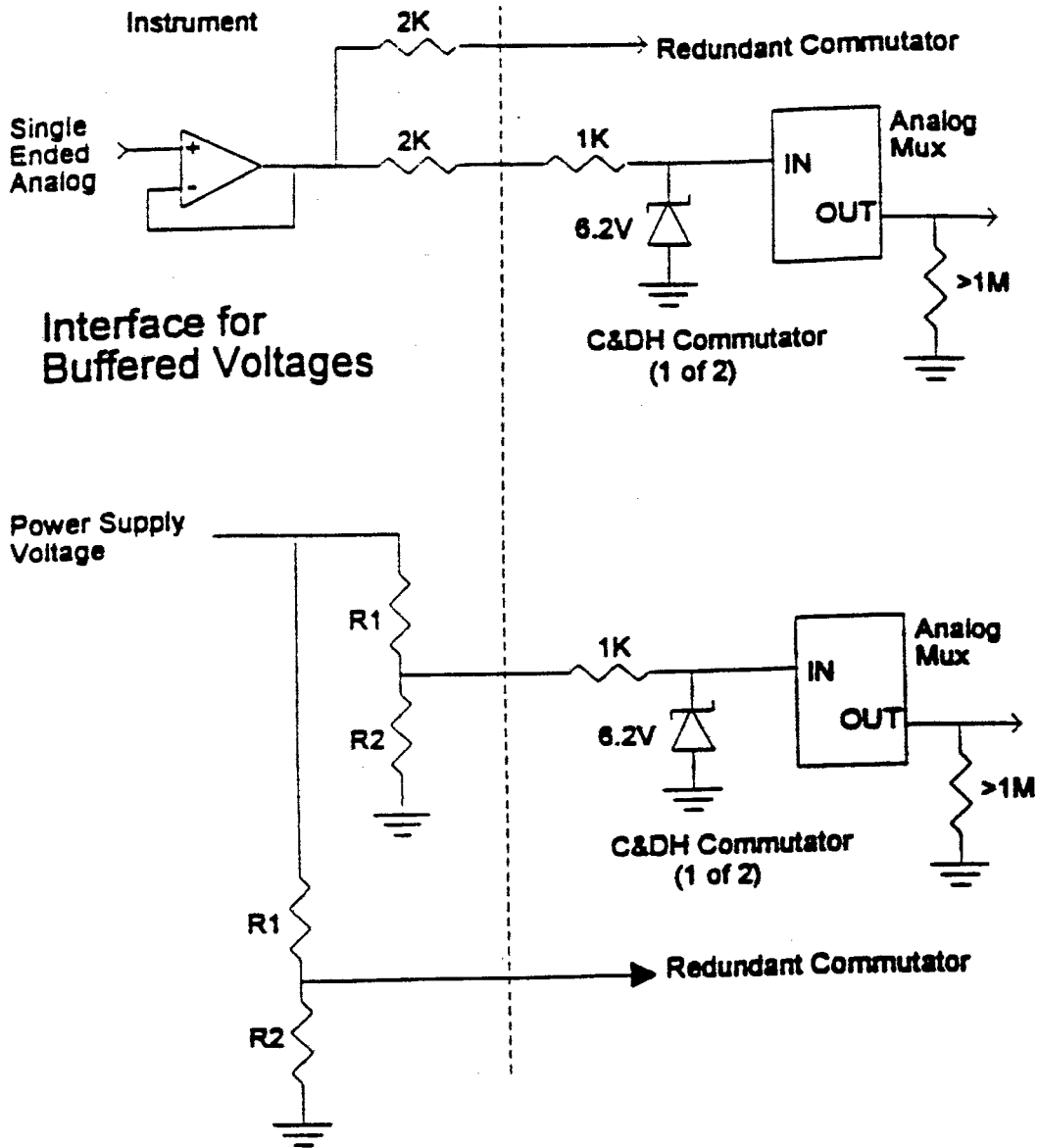

FSCM NO.	SIZE	DWG. NO.
88898	A	7345-9020
SCALE	DO NOT SCALE PRINT	SHEET 2-53

Figure 2.6.1.3.2-2 SWEPAM-I Single Ended Analog 0-5V Interface

Description

See appendix B paragraph 2.6.1.3.

Interface Circuit

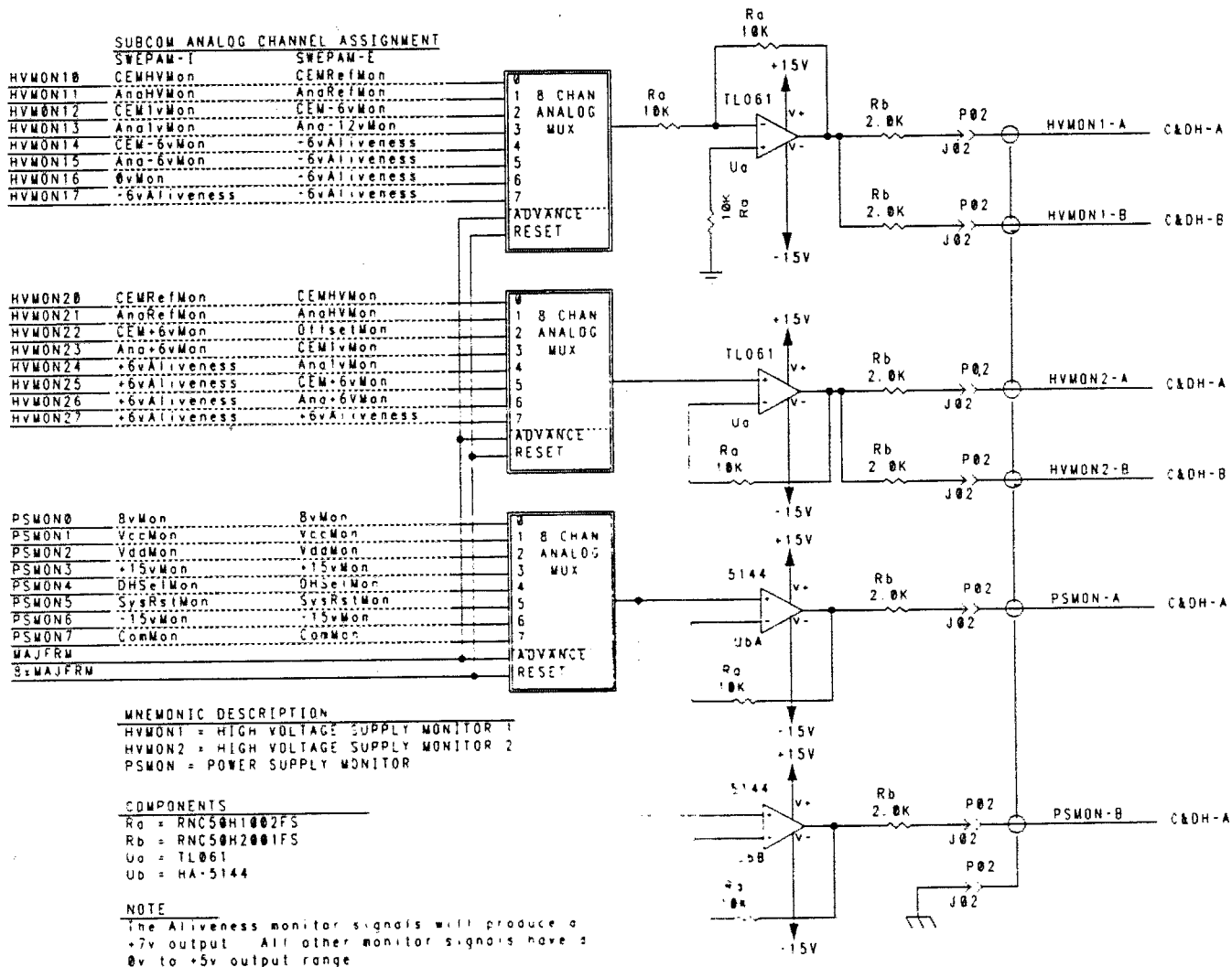

FSCM NO.	SIZE	DWG. NO.
88898	A	7345-9020
SCALE	DO NOT SCALE PRINT	SHEET 2-54

2.6.1.4.2 Interface

The first circuit interface is shown in Figure 2.6.1.4.2-1. **The instrument specific interface is shown in Figure 2.6.1.4.2-2.**

2.6.1.5 Temperature Sensor Interfaces

2.6.1.5.1 Description

Two temperature sensors are available for new instrument/sensor designs. The AD590 is for use over the range of -60 to $+100^{\circ}$ C. It is packaged in a 2 lead flatpack. The PT-103 is for use of the range of -100 to $+150^{\circ}$ C. It is a platinum wire sensor. Existing instrument/sensor designs using spacecraft powered will be treated in detail in their respective SIIS.

2.6.1.5.2 Interface

The first circuit interfaces are shown in Figure 2.6.1.5.2-1. Note that a separate temperature sensor is required to interface to each C&DH Component. **The instrument specific interface is shown in Figure 2.6.1.5.2-2.**

2.6.1.6 Sun Pulse and Spin Clock

2.6.1.6.1 Description

Each C&DH component is connected to a two axis Sun Sensor. Each Sun Sensor outputs an 8 bit X Sun Angle and an 8 bit Y Sun Angle. The C&DH Component generates a Sun Pulse based on the rising edge of the msb of the X-Axis Sun Sensor Angle. The Sun Pulse will be $732 \pm \text{TBD}$ μ s long. The C&DH Component will distribute the Sun Pulse to those instruments that require them. Each C&DH Component will also generate and distribute a Spin Clock. The Spin Clock will contain 16384 ± 10 (TBR) pulses between each rising edge of the Sun Pulse. The ± 10 (TBR) error includes all normal perturbations of the Sun Pulse, and not just error in the generation of the Spin Clock. A timing diagram of the Sun Pulse and Spin Clock is shown in Figure 2.6.1.6.1-1.

The instrument should use the same Data Handling Select Bit used to select the active Serial Digital Telemetry interface to select the active Sun Pulse and Spin Clock interface. Typically, an instrument would use a Data Command to generate the select bit and select the active side. **Note: users need to "remember" which side of the C&DH interface to use after resets.**

2.6.1.6.2 Interface

Each C&DH Component will provide each instrument with a Sun Pulse interface and a Spin Clock interface. The first circuit interface is shown in Figure 2.6.1.6.2-1. The components used to implement the interface to each C&DH Component shall be physically distinct and separate; no single component shall serve both redundant interfaces. **The instrument specific sun pulse interface is shown in Figure 2.6.1.6.2-2.**

FSCM NO. 88898	SIZE A	DWG. NO. 7345-9020
SCALE	DO NOT SCALE PRINT	SHEET 2-55

Figure 2.6.1.4.2-1 Differential Analog Interface

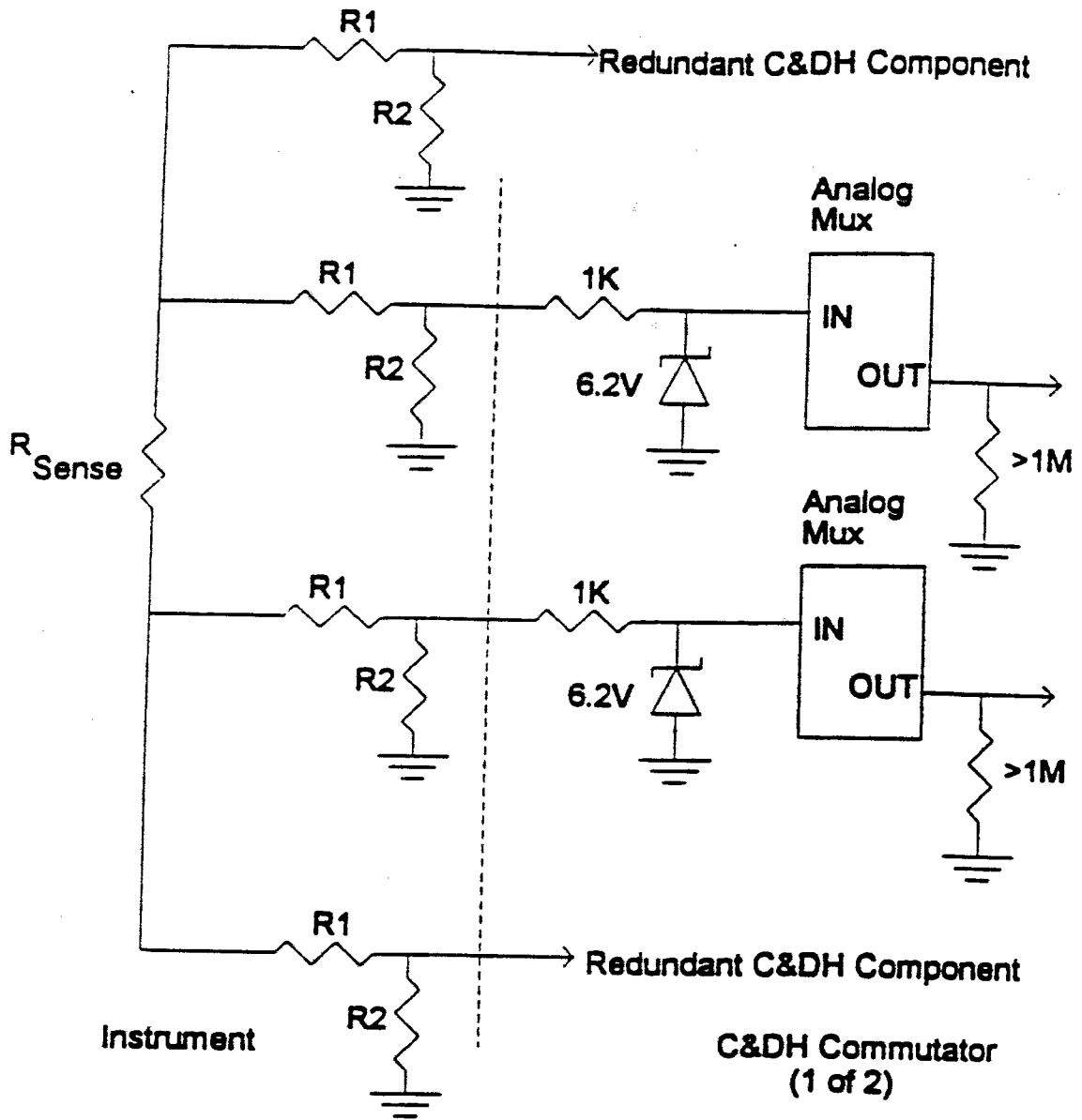

FSCM NO.	SIZE	DWG. NO.
88898	A	7345-9020
SCALE	DO NOT SCALE PRINT	SHEET
		2-56

Figure 2.6.1.4.2-2 SWEAM-I Differential Analog Interface

NOT APPLICABLE.

FSCM NO. 88898	SIZE A	DWG. NO. 7345-9020
SCALE	DO NOT SCALE PRINT	SHEET 2-57

Figure 2.6.1.5.2-1 Temperature Sensor Interfaces

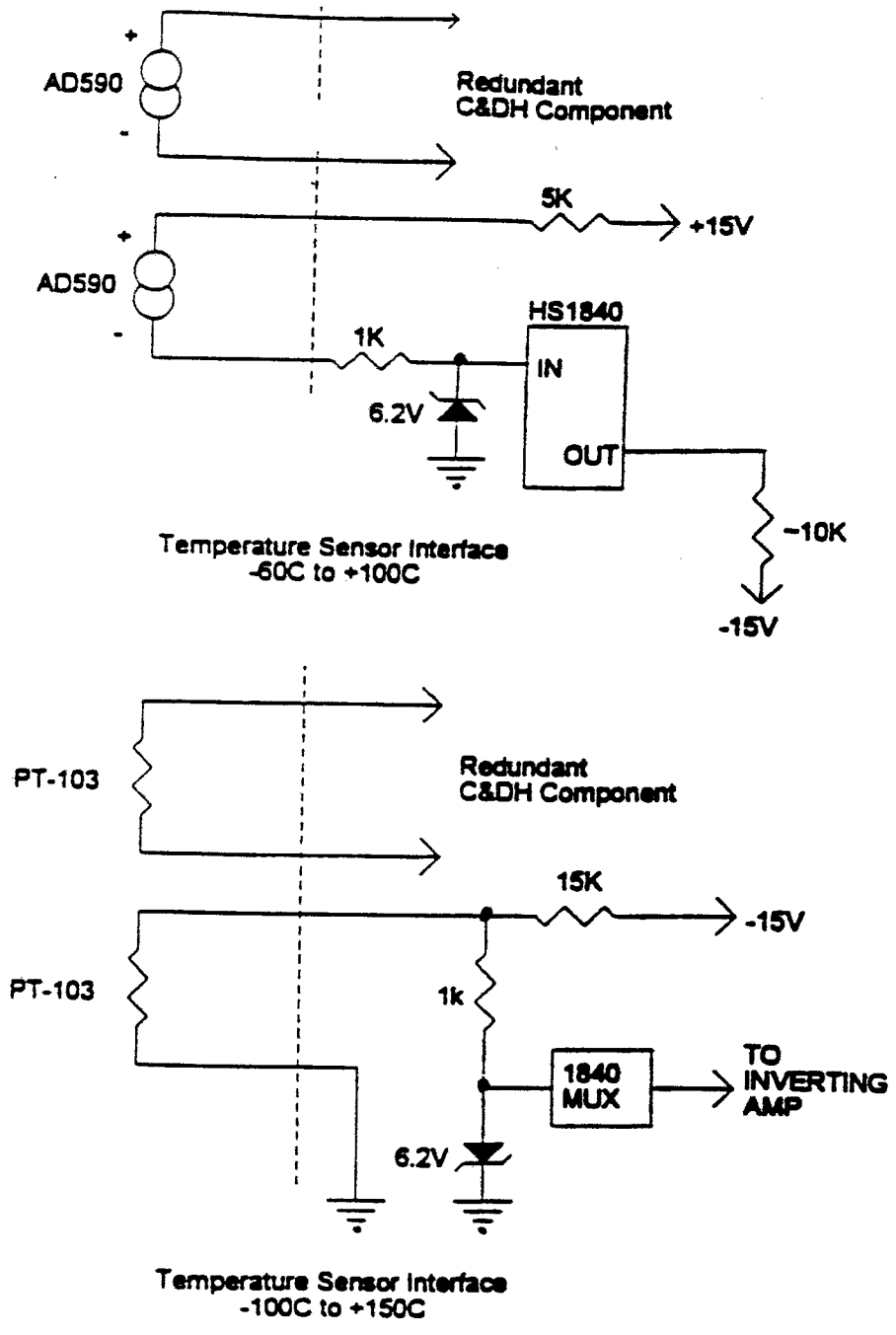

FSCM NO.	SIZE	DWG. NO.
88898	A	7345-9020
SCALE	DO NOT SCALE PRINT	SHEET
		2-58

Figure 2.6.1.5.2-2 SWEPAM-I Temperature Sensor Interfaces

Description

The SWEPAM-I has a single, redundant, AD590 temperature monitor interface. The transducers are installed in the E-Box on the low voltage power supply cavity at the end nearest the spacecraft interface. This monitor shall be used to determine if the instrument is within its operating limit prior to application of primary power to the instrument. If the SWEPAM-I remains thermally coupled, this monitor should approximately equal the interface temperature while the instrument is stable in the unpowered thermal state.

The SWEPAM-I instrument uses the standard AD-590 interface illustrated in Figure 2.6.1.5.2-1. See Page 2-19 for interface connector pin locations.

FSCM NO. 88898	SIZE A	DWG. NO. 7345-9020
SCALE	DO NOT SCALE PRINT	SHEET 2-59

Figure 2.6.1.6.1-1 Sun Pulse/Spin Clock Interface Timing

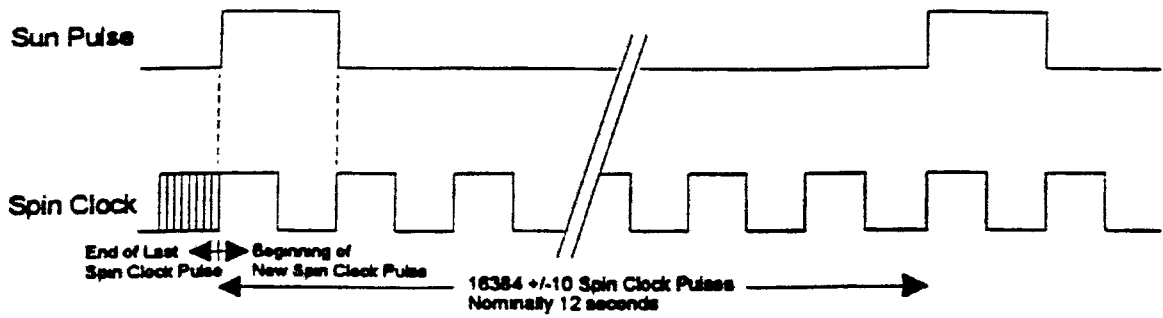

FSCM NO.	SIZE	DWG. NO.
88898	A	7345-9020
SCALE	DO NOT SCALE PRINT	SHEET 2-64

Figure 2.6.1.6.2-1 Sun Pulse/Spin Clock Interface

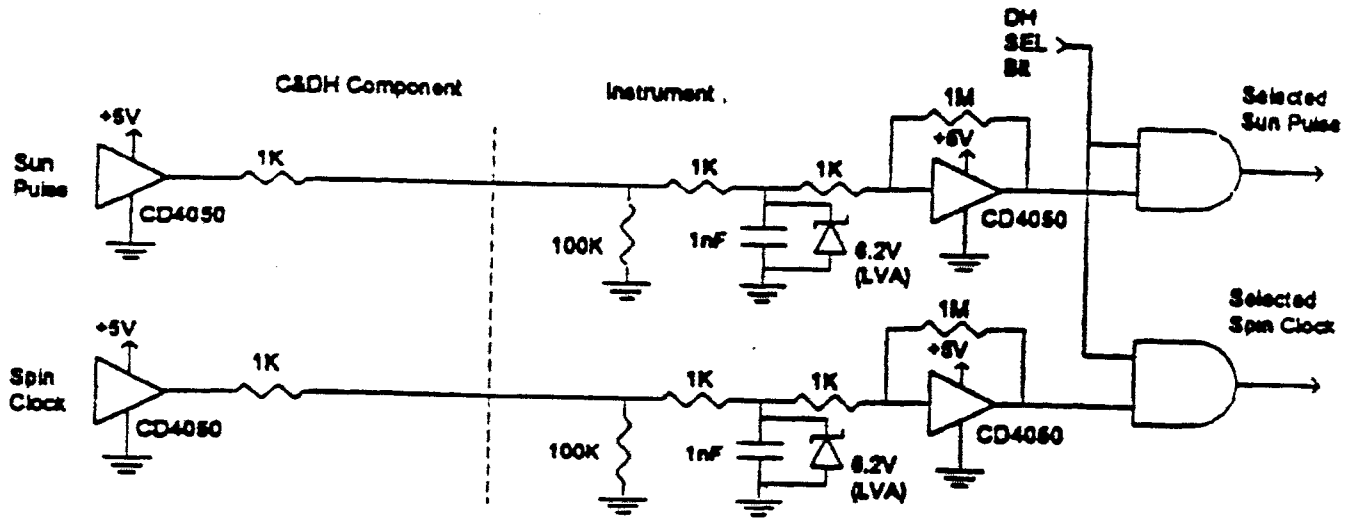

FSCM NO. 88898	SIZE A	DWG. NO. 7345-9020
SCALE	DO NOT SCALE PRINT	SHEET 2-61

Figure 2.6.1.6.2-2 SWEPAM-I Sun Pulse/Spin Clock Interface

The SWEPAM-I has no requirements for either a sun pulse or spin clock signal at the instrument's interface. The instrument will synchronize its data collection to the minor frame pulse. Yet the SWEPAM-I science requires knowledge of where in the spin the data was collected. Therefore, the spacecraft shall sample the spin phase counter on the leading edge of the minor frame pulse and include this sample in the minor frame data set.

FSCM NO. 88898	SIZE A	DWG. NO. 7345-9020
SCALE	DO NOT SCALE PRINT	SHEET 2-62

2.6.1.6.3 Sun Sensor Failure

If the Sun Sensor connected to the active Data Handling Component fails, the C&DH Component will no longer transmit a valid Sun Pulse and/or Spin Clock. The lack of a valid Sun Pulse will not be detected in a C&DH Component; a simulated Sun Pulse will not be generated and distributed. Sun Sensor failure would not be detected until the next ground pass (up to approximately 48 hours). At that time, the primary C&DH Component and Sun Sensor would be turned off, and the backup C&DH Component and Sun Sensor would be turned on.

2.7 PAYLOAD INSTRUMENT/SENSOR SYNCHRONIZATION SIGNALS

2.7.1 General

The spacecraft will supply sync. signals to the instruments/sensors which are related to the basic digital data rates, or are related to spacecraft generated attitude data. The characteristics of these sync. signals and the first circuit interfaces shall be documented in the SIIS's.

2.7.1.1 Available Synchronization Signals

The following synchronization signals are available from the spacecraft:

- a) Major Frame Pulse (an active high pulse at the start of every major frame)
- b) 2xMajor Frame Pulse (an active high pulse at the start of every 2 major frames)
- c) 8xMajor Frame Pulse (an active high pulse at the start of every 8 major frames).
- d) Minor Frame Pulse (an active high pulse at the start of every minor frame)
- e) Sun Pulse
- f) Spin Clock

FSCM NO. 88898	SIZE A	DWG. NO. 7345-9020
SCALE	DO NOT SCALE PRINT	SHEET 2-63

3.0 MECHANICAL INTERFACE REQUIREMENTS

This section describes the mechanical interfaces between the payload instruments and the spacecraft. These interfaces include the envelopes, mounting mass, products of inertia, and other mechanical forces which may be transmitted from the payload instrument to the spacecraft. The mechanical environment to which the Observatory will be tested (sine and random vibration, acoustic and shock) and recommended levels for instrument/sensor level testing are given in the ACE Environmental Specification APL 7345-9007.

3.1 INSTRUMENT PHYSICAL CHARACTERISTICS

3.1.1 Mass

The payload instrument/sensor mass including grounding straps, bolts, brackets, etc., shall be established and recorded in the Specific Instrument Interface Specification. Flight hardware shall be weighed, and the mass of each instrument/sensor assembly shall be documented to an accuracy of 1% or 1 pound, whichever is less. If the orbital configuration differs from the launch configuration (i.e., deployable covers, etc.), the mass in each configuration shall be specified. **Note: Mass estimates are shown in Figure 3.1.3-1. Please consult Caltech Table 3.2-1, Science Payload Mass Estimates.**

3.1.2 Size

Payload instrument/sensor size and envelope shall be established by the experimenter and documented in each of the Specific Instrument Interface Documents, including volume required for deploying sensor protective covers.

3.1.3 Center of Mass

Payload instrument/sensor center of mass shall be established to an accuracy of $\pm 10\%$ and documented in **Figure 3.1.3-1 and/or on the mechanical ICD drawing. Any deviation in center of mass due to deployment of protective covers shall defined and documented in the Figure 3.1.3-2.**

3.1.4 Moments of Inertia

The accuracy of payload instrument/sensor moments of inertia calculations shall have a goal of $\pm 10\%$ and documented in each of the Specific Instrument Interface Documents.

3.1.5 Mechanical Interface Drawings

Each payload instrument/sensor experimenter shall supply the following applicable Interface Control Drawings, Procedures, and Tables for inclusion in the Specific Instrument Interface Documents. **Note: S/C shall provide general drawing of instrument locations in the SIIS. All dimensions and notes shall be in English units of measure.**

- a) Envelope drawing - (Cover Stowed, Transition, Open)
- b) Center of Mass Location/Moments of Inertia

FSCM NO. 88898	SIZE A	DWG. NO. 7345-9020
SCALE	DO NOT SCALE PRINT	SHEET 3-1

Figure 3.1.3-1 SWEPAM-I Mass and Center of Mass

The mass of the SWEPAM-I shall be less than or equal to 9.92 lb (4.5 kg). The actual mass, center of mass and moments of inertia for the SWEPAM-I will be provided in a mass properties report as part of the acceptance data package. The resolution and accuracy of these measurements shall comply with the requirements set forth in paragraph 3.1. The current mass properties estimates are provided in Table 3.1.1. The reference axis and datum for these measurements are defined in Appendix A, "The SWEPAM-I Mechanical Interface Drawing(s)".

SWEPAM-I Mass Properties Estimate

	X/ixx	Y/lyy	Z/izz
Center of Mass (in)	4.65	4.27	4.00
Moments of Inertia (lb-in²)	157.0	73.6	148.4

Total Mass = 9.04 lb (4.1 kg)

The SWEPAM-I mass includes all internal cables, flight covers, flight plugs and pyrotechnics. The mass of the harness and mounting hardware required to interface the SWEPAM-I to the spacecraft are considered part of the spacecraft mass budget. The instrument thermal blankets are to be provided by the spacecraft integrator and are considered part of the spacecraft mass budget. The SWEPAM-I heritage thermal design is compatible with a direct coupled interface so there are no requirements for pads at the SWEPAM-I interface. If a thermally conductive/electrically insulative material is used between the instrument and the deck, this pad and chassis grounding strap shall be considered part of the spacecraft mass budget.

FSCM NO. 88898	SIZE A	DWG. NO. 7345-9020
SCALE	DO NOT SCALE PRINT	SHEET 2 2

Figure 3.1.3-2 Instrument Center of Mass Change Due to Cover Actuation

NEGLIGIBLE

FSCM NO. 88898	SIZE A	DWG. NO. 7345-9020
SCALE	DO NOT SCALE PRINT	SHEET 23

- c) Field-of View Drawing
- d) Alignment reference marks
- e) Mass
- f) Adjustments
- g) Full Sized Mechanical Interface Drawing
- h) Mounting Interface Preparation
- i) Mounting Hardware and Torque Specifications
- j) Connector Locations
- k) Connector Identification
- l) Red and Green Tag Items
- m) Test Connectors and Locations
- n) Special Grounding Provisions
- o) Access Requirements
- p) Handling Fixtures Interfaces and Lift Point Locations
- q) Heat Pipe Locations
- r) Location of Purge Connector
- s) Location of Pyro Actuators
- t) Critical Harness Routing/Requirements (u) Thermal/Optical Properties of Instrument Exterior Surfaces.

Specific instrument mechanical interface drawings are located in Appendix A.

3.2 INSTRUMENT MOUNTING

3.2.1 General

Payload instruments/sensors shall be designed for installation and removal from the ACE spacecraft without disassembly of the instrument/sensor. Instruments/sensors shall be mounted to the spacecraft by means of mounting hardware passing through flanges located on the payload instruments/sensors. Mounting hardware shall be accessible from the top of each

FSCM NO. 88898	SIZE A	DWG. NO. 7345-9020
SCALE	DO NOT SCALE PRINT	SHEET 3-4

instrument/sensor. Special mounting hardware if required, shall be provided by the instrument/sensor experimenter.

3.2.2 Instrument Mounting Flange Specifications

Instrument mounting hole size, mounting bolt size, mounting bolt torque, mounting hole configuration, position tolerance, and mount flange planarity shall be detailed in Figure 3.2.2-1. The spacecraft shall supply standard ANSI mounting hardware only. Note: Minimum mounting plane flatness shall be 0.015" over the longest dimension. Minimum flatness shall be verified prior to integration.

3.2.3 Instrument Mounting Hardware Specification

Mounting bolt size and quantity for each sensor shall be determined in accordance with standard practice. Mounting bolt threads shall be American Unified SAE Threads per ANSI 81.1 - 1982. Thread tolerance shall be class 2A/2B.

3.2.4 Mounting Hole Location Tolerance

Mounting hole locations shall have positional tolerances which do not exceed 0.014 inches diametrical clearance at maximum material condition. Mounting bolt hole clearance diameters shall not exceed +0.005/-0.001.

3.2.5 Instrument Mounting Repeatability

All instruments which must be removed and replaced after optical axis alignment shall provide means of preserving alignment on repeated mountings. **The method of preserving alignment shall be documented in Figure 3.2.5-1.** This requirement applies to critically aligned instruments only.

3.3 ALIGNMENT

Alignment of the payload instrument/sensor optical Axes shall be accomplished by control of the instrument/spacecraft mounting interface. **Specific alignment requirements shall be documented in Figure 3.2.2-1.**

The shift of the optical axes location with respect to the spacecraft axes, when exposed to the environment outlined in the ACE Environments Specification APL 7345-9007, shall not be greater than that defined in the Specific Instrument Interface Specification for each payload instrument.

3.3.1 Definition of Spacecraft Axes

The spacecraft axes are defined in Figure 3.3-1.

3.3.2 Definition of Instrument/Sensor Optical Axes

The instrument/sensor optical axes are defined by the use of Figure 3.3-2.

FSCM NO.	SIZE	DWG. NO.
88898	A	7345-9020
SCALE	DO NOT SCALE PRINT	SHEET
		3-5

Figure 3.2.2-1 SWEPAM-I Mounting Specification

Alignment

The SDT shall locate the instrument's bolt hole pattern to satisfy the field of view requirements of paragraph 3.3.2. The three sigma error of the actual SVA pointing direction shall not exceed the nominal by more than 1.0° including all errors due to mounting, structural alignment, attitude determination and control, thermal distortions and other error sources affecting the spacecraft. The uncertainty of this determination shall be no greater than 0.5° . It should be possible to achieve these requirements with a "bolt-on" process only. The mounting of the instrument shall also support the following requirements:

- a.) Mass characteristics of paragraph 3.1.1
- b.) Access requirements of paragraph 3.8
- c.) Thermal requirements of paragraph 4.0
- d.) The SWEPAM-I Instrument shall be mounted directly to the spacecraft deck.

Instrument Mounting Flange Specifications

The SWEPAM-I has six through hole mounting feet. These six feet are the only surfaces which contact the spacecraft deck. The balance of the SWEPAM-I foot print is offset by 0.020 inch from the mounting plane defined by the six feet. The planarity of the six mounting feet shall be better than 0.015".

Instrument Mounting Hardware Specifications

The mounting hardware shall be #10SAE. This hardware shall be provided by the SDT. For mounting torque see S.P. No. APL 1502.

Mounting Hole Location Tolerance

The location and size of the mounting holes are detailed in the SWEPAM-I mechanical interface drawing, Appendix A.

Typical Mounting Foot Detail

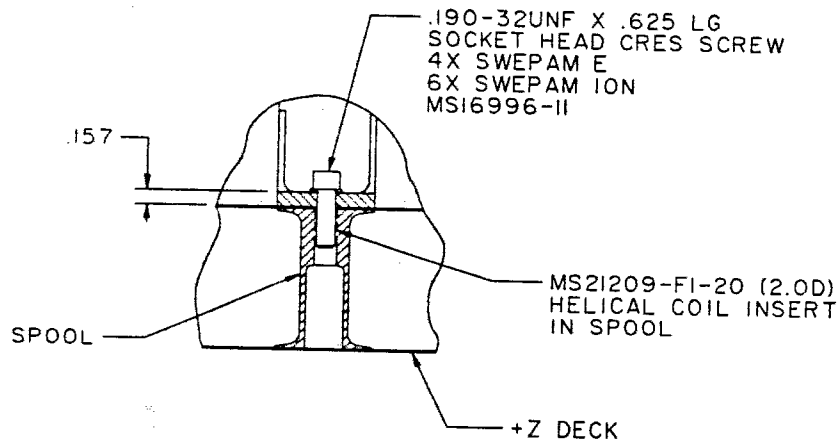

FSCM NO.	SIZE	DWG. NO.
88898	A	7345-9020
SCALE	DO NOT SCALE PRINT	SHEET 3-6

Figure 3.2.5-1 SWEPAM-I Instrument Mounting Repeatability

The SWEPAM-I Instrument has no mounting repeatability requirements as long as the alignment knowledge requirements of figure 3.2.2-1 are maintained.

FSCM NO. 88898	SIZE A	DWG NO. 7345-9020
SCALE	DO NOT SCALE PRINT	SHEET 3-7

Figure 3.3-1 Definition of Spacecraft Axes

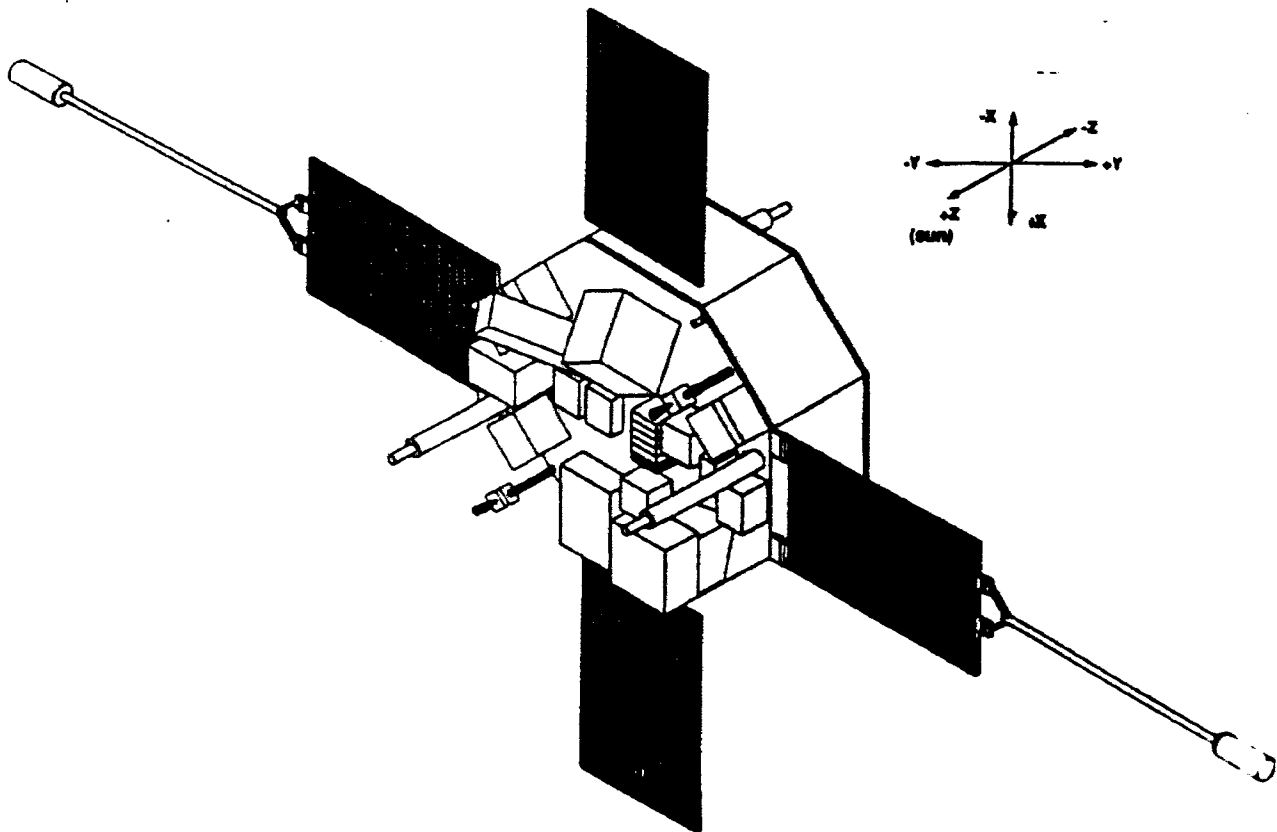

FSCM NO. 88898	SIZE A	DWG. NO. 7345-9020
SCALE	DO NOT SCALE PRINT	SHEET 38

Figure 3.3-2 Definition of SWEPAM-I Optical Axes

Axes Definition

The SWEPAM-I reference axes are a right hand definition as depicted in the SWEPAM-I Mechanical Interface Drawings (Appendix A) and described here;

X In the spacecraft/instrument mounting plane, originating from center of the reference mounting hole and passing through the center of the adjacent mounting hole.

Y In the spacecraft/instrument mounting plane, originating from center of the reference mounting hole and mutually perpendicular to the X and Z axis.

Z Normal to the spacecraft/instrument mounting plane and originating from center of the reference mounting hole.

Filed of View (FOV) Description

The SWEPAM-I has a single Sensor Viewing Axis (SVA). The projection of this axis on the instrument's XY plane is parallel to the Y reference axis and "looking" in the +Y direction. The SWEPAM-I Mechanical Interface Drawing define the SVA and FOV geometry relative to the instrument's reference axes. The SDT shall mount the instrument to achieve an unobstructed FOV while at the same time assuring the instrument's +Y reference axis and therefore SVA are parallel to a spacecraft spin radial.

Viewing Constraints Diagram

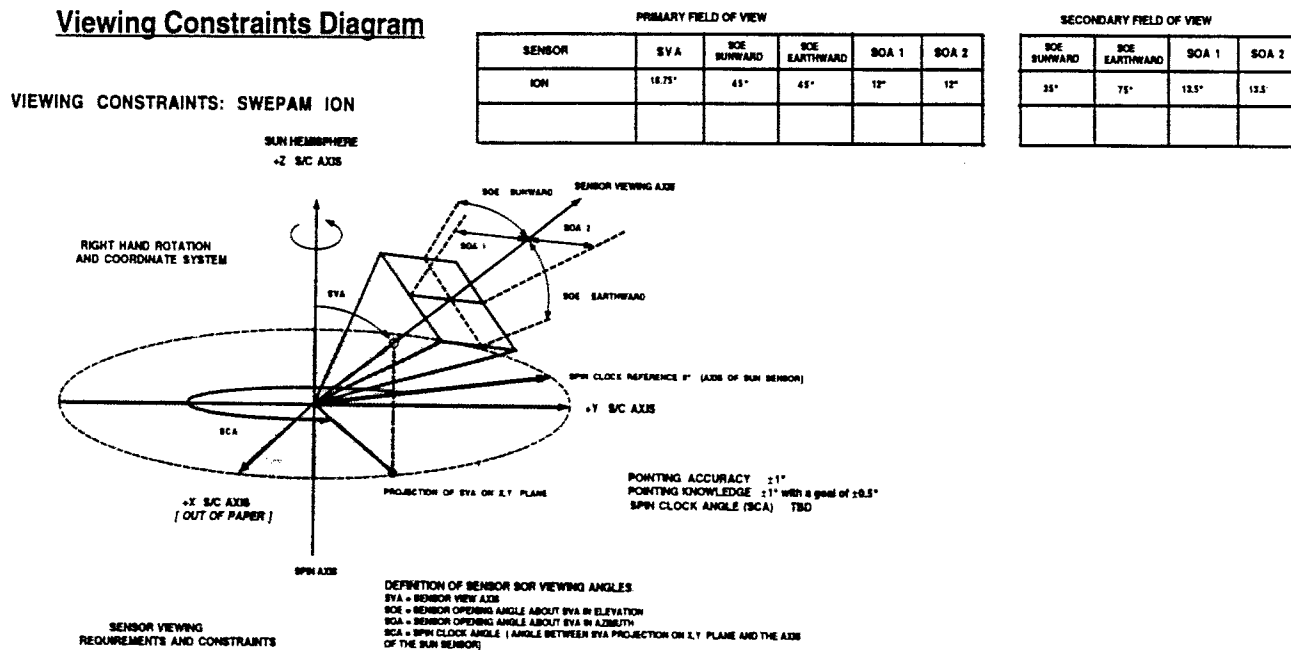

FSCM NO. 88898	SIZE A	DWG. NO. 7345-9020
SCALE	DO NOT SCALE PRINT	SHEET 3-9

3.3.3 Alignment of Optical Axis

The alignment of the instrument/sensor optical axes shall be accomplished by positioning the mounting hole locations, on the spacecraft, with respect to the spacecraft coordinate system. The optical axes of the instrument/sensor shall be related to the instrument/sensor mounting hole pattern. The instrument/sensor experimenter shall measure the optical axis alignment with respect to the mounting hole pattern to verify the validity of the optical axis alignment.

3.4 HARNESSTIE POINTS

Harness tie points, if needed, on an instrument/sensor shall consist of individual cable clamps attached to the instrument/sensor, or lacing clips bonded with epoxy adhesive.

Payload instruments/sensors shall provide suitable cable clamp tie points or areas free from surface coatings suitable for the application of epoxy adhesive. **The tie points or bonding areas are shown in Figure 3.4-1 or on the mechanical drawings.** The spacecraft shall provide a general harness drawing.

3.5 PAYLOAD INSTRUMENT/SENSOR LOAD DESIGN

3.5.1 General

The payload instruments/sensors shall be designed to provide primary load paths from the sensor masses to the sensor mounting flange in the most direct path practical.

3.5.2 Load Directions

Payload instruments/sensors shall be designed to withstand static and dynamic loads in any direction as specified in the ACE Environments Specification; APL 7345-9007. Payload instruments/sensors shall be designed to the stiffness described in APL 7345-9007.

3.6 PAYLOAD INSTRUMENT/SENSOR PROTECTIVE COVERS

3.6.1 Non-Flight Protective Covers

Protective covers shall be provided, if necessary, with each payload instrument/sensor to preclude damage caused by the entrance of foreign particles to sensitive areas and the rigors of handling, spacecraft integration and bench testing. Protective Covers shall be easily accessible and removable at the launch site. All protective covers shall be color coded and labeled "NON-FLIGHT" or shall be red-tagged. Covers for all interface connectors shall also be provided.

3.6.2 Flight Covers and Doors

The deployment of flight covers and doors shall not cause disturbance to other instruments on the spacecraft by blocking radiators, solar panels or the field-of-view of other instruments. **All sensor covers, their operational description, and their deployment envelope shall be described and documented in this document and in Figure 3.6.2-1.**

FSCM NO. 88898	SIZE A	DWG. NO. 7345-9020
SCALE	DO NOT SCALE PRINT	SHEET 3-10

Figure 3.4-1 Location of SWEPAM-I S/C Harness Tie Points

Most SWEPAM-I surfaces are painted surfaces and not generally considered compatible with epoxy bonded cable ties. Coating free surfaces have been provided around the aperture to permit installation of epoxy bonded Velcro zippers for thermal blanket installation. These areas shall not be used for interface cable tie points.

The IDT shall assure that all non interface cables (cables from the electronics box to the sensor and cables from the pyro interface connector to the pyros) are adequately secured. The interface connectors are located on the instrument such that there should be no need to secure interface cables to the instrument with cable ties. However, if the SDT does identify a real need for a cable tie on the SWEPAM-I box, the IDT will do it's best to identify or provide a suitable tie point. At that time, the SWEPAM-I Mechanical Interface Drawing will be updated to specifically identify these tie points and any limitations that may apply.

FSCM NO.	SIZE	DWG. NO.	
88898	A	7345-9020	
SCALE	DO NOT SCALE PRINT		SHEET 3-11

Figure 3.6.2-1 SWEPAM-I Sensor Cover Data

Non-Flight Protective Covers

The SWEPAM-I shall be delivered with ESD safe plastic covers installed on all flight interface connectors. If the need should arise for the SDT to install protective covers on the interface connectors, only ESD safe covers shall be used.

Prior to launch the pump-out port and aperture will be sealed and the purge port will be capped to protect the sensor. These are all non-flight covers.

A non-flight high voltage disable plug shall be provided. This non-flight plug replaces the flight plug on the test connector, J04, as needed.

When the flight plug has been removed from the test connector, it shall remain tethered to the instrument and have it's own protective cover installed. This protective cover shall be "red-tagged" to indicate that a non-flight configuration exist either because the high voltage disable plug or ground support equipment has been mated to the test connector.

Flight Covers and Doors

Prior to installation of the payload shroud during launch preparation, the IDT will need to remove the seals from the pump-out port and aperture, install the light baffle, install the flight aperture cover, assist the SDT connect the instrument to the spacecraft purge manifold and connect the high voltage to the sensors. Connecting the high voltage requires removing a protective cover on the high voltage make/break connector, moving a jumper and then reinstalling the protective cover. This is part of a single integrated procedure. Rather than each piece of this non-flight configuration being "red-tagged" a single red tag will be applied to indicate the procedure must be performed. The procedure will conclude with a count of all the non-flight items and removal of the "red-tag". The instrument shall not be operated after this procedure has been completed unless the non-flight high voltage disable plug is installed on the test connector, J04. A final inspection shall be made before the spacecraft is enshrouded to assure the flight plug is installed on J04.

The SWEPAM-I aperture cover deploys such that it is always within the envelope of the instrument and therefore causing no disturbance to the spacecraft or other instruments.

The locations of the aperture, HV make/break jumper, pump-out port and purge port are identified on the SWEPAM-I mechanical Interface Drawing in appendix A.

FSCM NO	SIZE	DWG. NO.
88898	A	7345-9020
SCALE	DO NOT SCALE PRINT	SHEET 3-12

3.7 PAYLOAD INSTRUMENT/SENSOR UNIQUE TOOLING AND HANDLING FIXTURES

3.7.1 Optical Tooling

Instruments/sensors which require unique optical equipment to define operational alignment shall provide the needed equipment prior to spacecraft integration. Equipment descriptions, designations, and alignment procedures shall be documented in the Figure 3.7.1-1.

3.7.2 Handling Fixtures

Handling fixtures shall be provided, for all instrument/sensors, by the instrument/sensor experimenter for all equipment which exceed 35 lbs. The handling fixtures shall be used to remove the instrument/sensor from the shipping container and for the installation of the instrument/sensor aboard the spacecraft. **Note: The handling fixture shall be proof tested to 2.5x the rated load. The period of certification shall be 1 year.**

3.8 PAYLOAD INSTRUMENT/SENSOR ACCESSIBILITY

All instrument/sensor experimenters shall identify the times, in the integration test flow, when access to their flight hardware is required. **The type of access, duration, test equipment required and procedures shall be documented in Figure 3.8-1.** After integration instruments shall not be removed except to repair faults or to accomplish prearranged (approved) calibration procedures.

NOTE: At some point (TBD) in the spacecraft integration, access to individual instruments/sensors may be prohibitively time consuming and/or expensive. Instruments shall provide information concerning access holes needed in thermal blankets.

3.9 PAYLOAD INSTRUMENT/SENSOR IDENTIFICATION AND MARKING

All flight hardware and shall be marked with appropriate (AXXXX) identification. The markings shall be permanent, resistant to chipping and located away from points of physical wear. Interface connectors, test points and adjustments shall be clearly labeled. (AXXXX-JXX). These "A" numbers shall be supplied by the spacecraft. **A list of instrument identification numbers is found in Figure 3.9-1**

3.10 PAYLOAD INSTRUMENT/SENSOR MAINTAINABILITY

The maintainability guidelines presented below shall be considered to the extent practical during all design efforts .

- a) Designs should avoid projecting parts which may be easily damaged during handling.
- b) Designs should be configured to stand alone in a stable manner.
- c) All design components which may be inadvertently reversed or misaligned during integration should be keyed.

FSCM NO. 88898	SIZE A	DWG. NO. 7345-9020
SCALE	DO NOT SCALE PRINT	SHEET 213

Figure 3.7.1-1 SWEPAM-I Optical Tooling Requirements

No optical tooling, alignment procedure or handling fixtures are required.

FSCM NO. 88898	SIZE A	DWG. NO. 7345-9020
SCALE	DO NOT SCALE PRINT	SHEET 3-14

Figure 3.8-1 SWEPAM-I Access Requirements

Access Points:

1.) **Test Connector:** The test connector is provided for trouble shooting, not for normal verification test flow, therefore access to this connector is infrequent. However, the SDT shall assure that access is possible up to the point the payload shroud is installed prior to launch. A high voltage disable plug will also be provided which, when mated to the test connector, inhibits activation of the instrument's high voltage supplies by any command or processor control function.

2.) **HV make/break jumper:** This jumper remains in the dummy load position until the last possible moment before launch. Only during the pre launch close out procedure will the jumper be moved to enable HV to the sensor. This procedure would be performed before the payload shroud is installed. **NOTE:** After the jumper is moved to the flight position, the SWEPAM-I shall not be operated again unless the high voltage disable plug is installed or until the instrument has been launched and the required venting time has been observed.

3.) **Pump Out Port and Aperture:** The pump-out port and aperture remain sealed until just before launch. At that time, the pump-out port seal is replaced with the light baffle and the aperture seal with the aperture flight cover mechanism.

4.) **Purge Port:** There are three times in the I&T flow where the purge port must be accessed;

a.) Before the Observatory Thermal Vacuum testing to install the charcoal filter.

b.) After Observatory Thermal Vacuum testing to purge and reseal the sensor.

c.) During the pre launch close out to connect to the spacecraft purge manifold.

Instrument Removal Requirements

There are two times during the I&T flow that the SWEPAM-I will need to be removed from the spacecraft.

1.) After the completion of the Observatory environmental test program where the instrument will be returned to the IDT for an end-to-end test in a beam facility.

2.) To execute the pre-flight close out procedures.

All other accesses should be possible with the instrument still on the spacecraft.

FSCM NO. 88898	SIZE A	DWG. NO. 7345-9020
SCALE	DO NOT SCALE PRINT	SHEET 3-15

Figure 3.9-1 Instrument Identification Numbers

INSTRUMENT	ID NUMBER	SENSOR A (-Y)	SENSOR B (+Y)
EPAM	A1100		
EPAM ADAPTER	A1101		
EPAM BRACKET	A1102		
MAGNETOMETER	A1050	A1430	A1470
ULEIS TELESCOPE	A1030		
ULEIS DPU	A1020		
ULEIS ANALOG	A1010		
SEPICA	A1040		
SWIMS	A0410		
SSSDPU	A1070		
SWICS	A1090		
SWEPAM ION	A1120		
SWEPAM ELECTRON	A1080		
CRIS	A0810		
SIS	A1060		

The SWEPAM-I shall be marked SWEPAM-I, A1120. The location of this marking is identified in the Mechanical Interface Drawings. At this time it appears best to leave the original instrument identification tags in place. Removal of these tags would necessitate repair to painted surfaces.

Connectors are marked clearly with the Jxx. The IDT has no plans to add the A1120 marking to each connector designator.

FSCM NO. 88898	SIZE A	DWG. NO. 7345-9020
SCALE	DO NOT SCALE PRINT	SHEET 3-16

- c) All design components which may be inadvertently reversed or misaligned during integration should be keyed.
- d) Instruments/sensors shall be designed to prevent ESD malfunctions caused by normal space laboratory handling and integration practices.

3.11 PAYLOAD INSTRUMENT/SENSOR STORAGE

Instruments/sensors shall be capable of being stored for at least 6 months under conditions of temperature and humidity specified in Figure 3.11-1 without requiring major repair, maintenance or recalibration. Any refurbishment requirements after storage shall be documented in Figure 3.11-2. Note: JHU/APL will supply N₂ and plumbing to the instrument purge connector for all off-line operations, which require purge, and for storage periods resulting from integration delays or other conditions.

FSCM NO. 88898	SIZE A	DWG. NO. 7345-9020
SCALE	DO NOT SCALE PRINT	SHEET 3-17

Figure 3.11-1 SWEPAM-I Storage Requirements

As long as the SWEPAM-I is handled and stored per the Operation and Handling Constraints and Hazards of paragraph 1.6, the instrument can be stored indefinitely without the need for refurbishment.

FSCM NO	SIZE	DWG. NO.	
88898	A	7345-9020	
SCALE	DO NOT SCALE PRINT		SHEET 318

Figure 3.11-2 SWEPAM-I Refurbishment After Storage

NONE REQUIRED

FSCM NO. 88898	SIZE A	DWG. NO. 7345-9020
SCALE	DO NOT SCALE PRINT	SHEET 3-19

4.0 PAYLOAD INSTRUMENT/SENSOR THERMAL INTERFACE REQUIREMENTS

4.1 GENERAL

Note: In keeping with the concept of a combined GISS and SIIS the general thermal requirements of the GISS are included in this section. Specific instrument thermal interface requirements are shown in Figures and are referenced to the general GISS paragraph numbers.

Instrument/sensor thermal dissipation will be removed via conductive transfer to the spacecraft, radiative transfer from the instrument/sensor to its external surroundings, or a combination of both depending upon the nature of the thermal interface. Any instrument requiring radiative coupling to space will be able to greatly simplify its thermal design effort by maintaining an isolated interface with the spacecraft. An isolated interface is strongly urged for most instruments. Boxes with no apertures and requiring no space view may be conductively tied to the spacecraft and covered with MLI.

Thermal control systems aboard the spacecraft will ensure that the deck temperature at each instrument/sensor mounting location remains within the limits specified in the individual SIIS (Specific Instrument Interface Specification). To accomplish this task, the interface characteristic for each instrument must be included in the overall spacecraft thermal model

4.2 SPACECRAFT THERMAL DESIGN AND CONTROL

The ACE spacecraft consists of two honeycomb decks tied together by internal supports and honeycomb side panels. The two decks are octagonally shaped with four solar panels extending horizontally from the +X and +Y deck edges, facing the sun hemisphere. The spacecraft is spinning at approximately 5 rpm. The axis of rotation points to within 20 degrees of the sun.

The preliminary spacecraft thermal design environment is illustrated in Figure 4.2-1. The upper deck of the spacecraft is covered by thermal insulation to shield it from the sun as much as possible. Heat is rejected from the +Z forward deck via radiators which are attached to all eight edges of the octagon. The radiators face radially away from the axis of symmetry of the spacecraft. The size of the various radiators will be determined as the thermal design matures.

The spacecraft side panels are used primarily for mounting spacecraft components. However, the +X/-Y and -X/+Y panels have been allocated for the isolated mounting of the SWIMS and CRIS instruments, respectively. The spacecraft thermal design will minimize the heat exchange between individual side panels and space by enclosing all of the panels in thermal insulation blankets that extend from the bottom of the instrument deck radiators to the beginning of the aft deck attach flange. For the instruments mounted on the side panels, the insulation blankets will serve to radiatively isolate the instrument from the side panel. Sun sensor and Star Scanner apertures will not be covered with MLI.

The spacecraft aft deck serves as the mounting platform for the propulsion system. In addition, components of the RF subsystem are mounted to the space-facing side of the aft deck. The observatory attach fitting is bolted to the aft deck and will also be used as a thermal radiator. Thermal blankets will closeout the areas around the exposed antenna dishes.

FSCM NO.	SIZE	DWG. NO.
88898	A	7345-9020
SCALE	DO NOT SCALE PRINT	SHEET 4-1

Figure 4.2-1 Preliminary Spacecraft Thermal Design Environment

Legend

Conductively Coupled 

Radiatively Coupled 

Dissipating Device 

■ = Ultem Spacer
0.5" D, .375" High

Orbit Attach Flange
Part MLI / Part Radiator

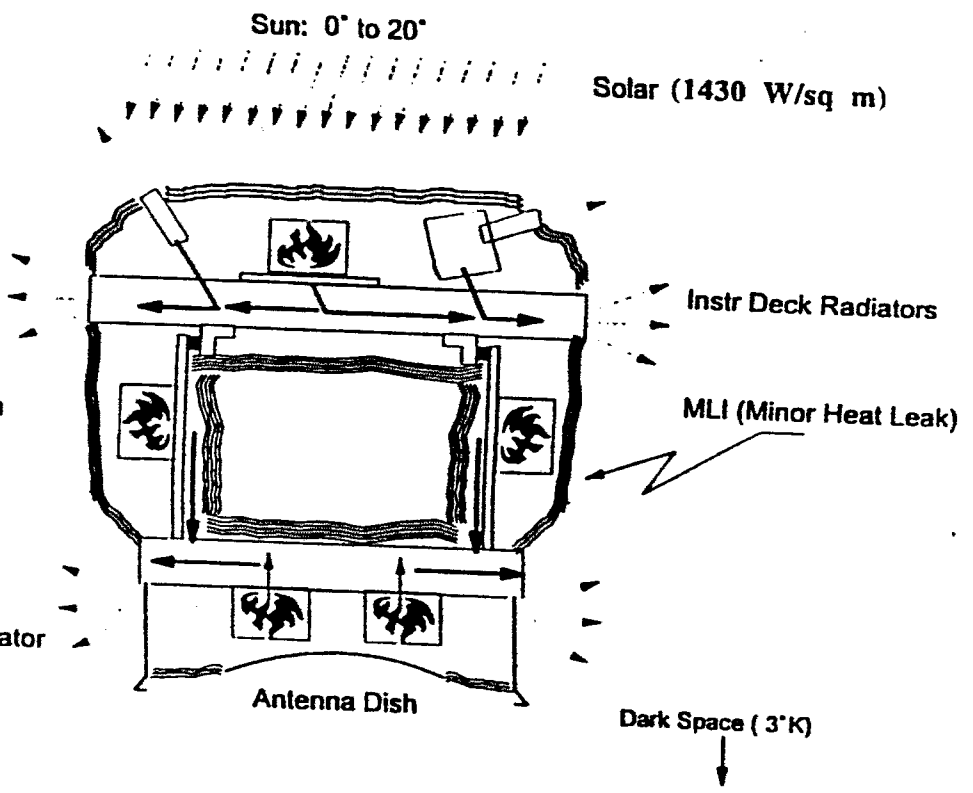

FSCM NO. 88898	SIZE A	DWG. NO. 7345-9020
SCALE	DO NOT SCALE PRINT	SHEET 42

The spacecraft will be thermally stable at the Earth-Sun libration point since there is very little variation in the thermal environment. The main cause of any thermal perturbations will be internal power fluctuations. However, customary thermal analysis techniques require that many of the thermal design parameters be allowed to vary between hot and cold cases to ensure that the design is robust. Therefore, for a spacecraft which is expected to be in a stable environment, the resultant predicted temperature variations and heater power requirements are primarily driven by the degree of variation in the thermal parameters.

Incident external environmental fluxes are included in Figure 4.2-1 for use by the instrument thermal engineers. The flux values are assumed to be averaged over the spin of the ACE spacecraft. At 5 rpm, transient effects are expected to be minimal.

4.2.1 Spacecraft-Instrument Interface Temperatures

The interface temperatures specified for the instruments and their components are always assumed to be on the spacecraft side of the interfaces. A protoflight design and test interface range is specified for each instrument depending on its type of mounting. The instrument must be capable of maintaining the temperature of all its components within the operational ranges given in the SIIS while the deck interface temperature is within the design/test range. The design/test interface temperature range is 5° C outside of the spacecraft operating range. In addition, a survival range is specified for each instrument interface. While the observatory is in survival mode, i.e., all instruments off and spacecraft in survival mode, each instrument must maintain the temperature of its components within the survival ranges given in the SIIS.

For cases in which one or more instruments are powered off while the spacecraft is still in operational mode, instrument interface temperatures will be maintained within operational limits by interface heaters located on the deck. Under these circumstances, the ACE Observatory is still defined as being in operational mode. For analysis, instruments should always use the spacecraft design/test temperature range of their interfaces.

The instruments should recognize the difference between the interface temperature ranges specified in Section 4.2.1 and the various temperature ranges specified in the SIIS. The interface temperatures should be used as inputs to the instrument thermal models. For an isolated instrument, the interface temperature should, by design, have little impact on its internal component temperatures. An instrument with a conductively coupled interface will have a greater dependence on interface temperature, but, only as a more significant input to its thermal model. The interface ranges are not specifically required to fall within any component range defined for an instrument. However, the definition of the interface temperature ranges for an instrument is consistent with the requirements of its responsible thermal engineer.

The spacecraft is responsible for the transition of interface temperatures from survival to operational mode. However, each instrument is responsible for transitioning its components from survival to turn-on, given that the interface temperatures shall be within the design/test range specified in this section. The simplest approach is for an instrument to define its minimum survival and turn-on temperatures to be the same, if possible.

Control of Observatory deck temperatures at the instrument mounting locations will depend on the choice of individual mounting configurations. Instrument sensors which require a

FSCM NO. 88898	SIZE A	DWG. NO. 7345-9020
SCALE	DO NOT SCALE PRINT	SHEET 4-3

thermally conductive interface with the deck can expect a design/test range of -15°C to $+15^{\circ}\text{C}$ and a survival range of -25°C to $+15^{\circ}\text{C}$ on the spacecraft side of the interface. These ranges are consistent with the instrument temperature requirements defined in each SIIS and should be used for instrument thermal analyses. Instrument sensors with thermally conductive interfaces have a direct effect on spacecraft thermal design. Therefore, the demands placed by the spacecraft on instruments with thermally conductive interfaces are more severe than for those instruments with isolated interfaces.

Instrument electronics boxes that require thermally conductive interfaces with the deck will be treated as general electronics unless,

- a) The box cannot be thermally separated from its sensor; or,
- b) The box has component limitations preventing exposure to the typical design range for general electronics.

General electronics boxes have a design/test temperature range of -23°C to $+55^{\circ}\text{C}$ at their mounting interfaces. The survival temperature range is also defined as -23°C to $+55^{\circ}\text{C}$. Instrument electronics boxes which cannot be treated as general electronics must negotiate their interfaces with the spacecraft thermal engineer. Allowable temperature ranges shall be included in the appropriate SIIS.

Instruments which are isolated from the deck have only a minor effect on spacecraft thermal design and are less sensitive to the interface temperature. Interface temperatures for isolated instruments shall have a design/test range of -20°C to $+40^{\circ}\text{C}$. The survival range shall be -25°C to $+40^{\circ}\text{C}$ on the spacecraft side of the interface. These ranges are consistent with the temperature requirements defined in the SIIS for each isolated instrument and should be used in the instrument thermal analyses.

Instruments mounted to the ACE side panels will be exposed to a design/test interface temperature range of -10°C to 40°C . During the Observatory survival mode, instrument interfaces on the side panel will be maintained within the same range of -10°C to $+40^{\circ}\text{C}$. Instruments mounted to the aft deck will be exposed to an design/test interface temperature range of -10°C to $+45^{\circ}\text{C}$. During the Observatory survival mode, instrument interfaces on the aft deck will be maintained at the same range of -10°C to $+45^{\circ}\text{C}$. **Specific instrument interface temperature information is found in Figure 4.2.1-1**

4.3 Instrument Sensor Thermal Design and Control

The instrument/sensor experimenters shall be responsible for the thermal design of their instruments/sensors. The primary methods of thermal control available to the instrument/sensor designers are illustrated in Figure 4.3-1 and are described below. **Figure 4.3-2 illustrates the specific instrument thermal control methods.** The choice of thermal control method will be made by the spacecraft thermal engineer in conjunction with the instrument/sensor engineer. For all methods of thermal control, the instrument thermal engineer must take into account the allowable deck temperatures on the spacecraft side of the thermal interfaces.

- a) **Local Thermal Control:** Thermal dissipation is radiated directly from the external instrument/sensor surfaces to space. All non-radiator surfaces must be radiatively isolated from the spacecraft and other instruments. In addition, the instrument must be conductively isolated from the spacecraft. The instrument thermal engineer must be able to show, by analysis, a thermal interface resistance of $\geq 20^{\circ}\text{C/W}$. Finally, the

FSCM NO. 88898	SIZE A	DWG. NO. 7345-9020
SCALE	DO NOT SCALE PRINT	SHEET 44

Figure 4.2.1-1 SWEPAM-I Interface Temperature Data

Reference Paragraph 4.2.1

The SWEPAM-I Instrument is conductively coupled to the +Z instrument deck. The SWEPAM-I Instrument contains no component limitations preventing exposure to the typical design temperature range for general electronics. The in-spec operating range is -20 to +45°C. See Figure 4.4-1 for the full set of temperature limits.

FSCM NO. 88898	SIZE A	DWG. NO. 7345-9020
SCALE	DO NOT SCALE PRINT	SHEET 4-5

Figure 4.3-1 Typical Instrument/Sensor Thermal Control Methods

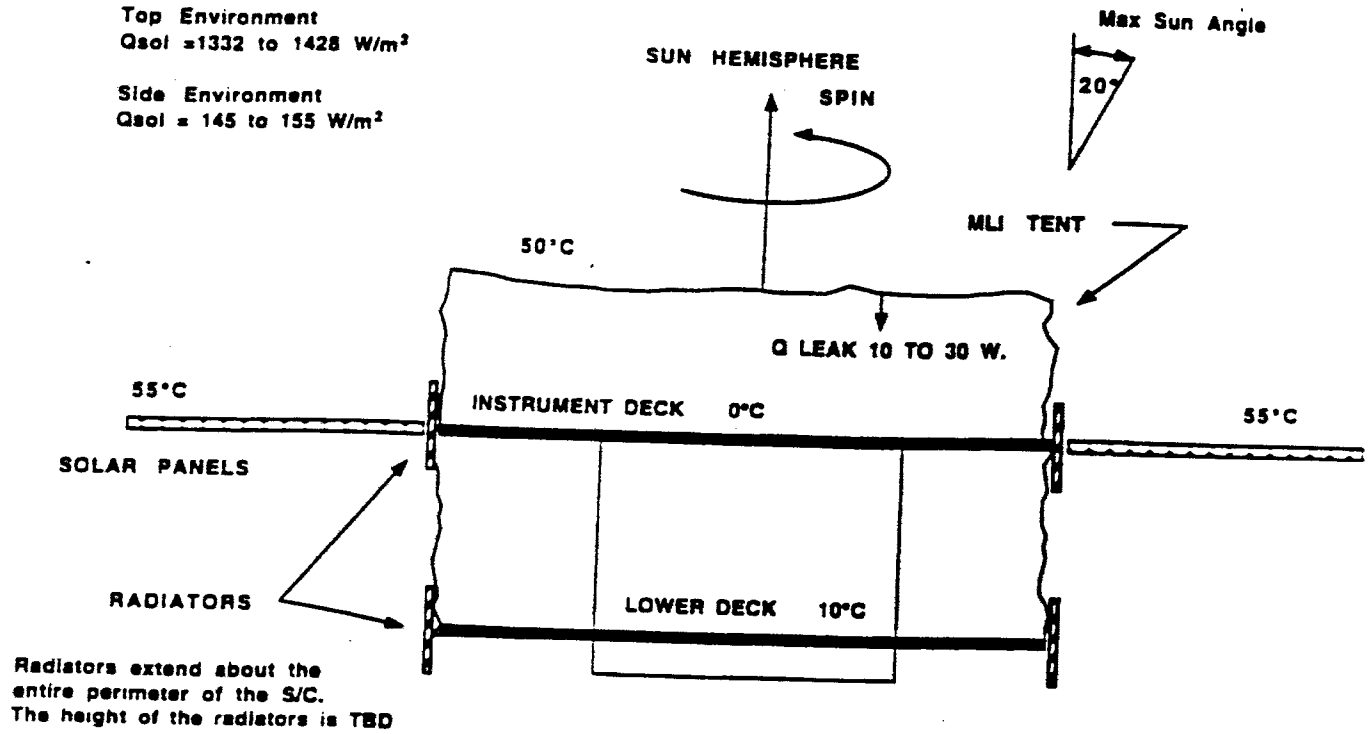

FSCM NO. 88898	SIZE A	DWG. NO. 7345-9020
SCALE	DO NOT SCALE PRINT	SHEET 46

Figure 4.3-2 SWEPAM-I Thermal Control Method

The SWEPAM-I thermal design is a passive design, relying on the +Z deck temperature, selected thermal surfaces and MLI blanket for thermal control. The instrument's electronics box is thermally coupled to the spacecraft +Z deck. The sensor and sensor amplifiers are electrically isolated from the electronics box resulting in a moderate amount of thermal isolation between the sensor and the electronics box. The sensor aperture is exposed to space. As such, the SWEPAM-I thermal design falls into the "Hybrid Thermal Control" category .

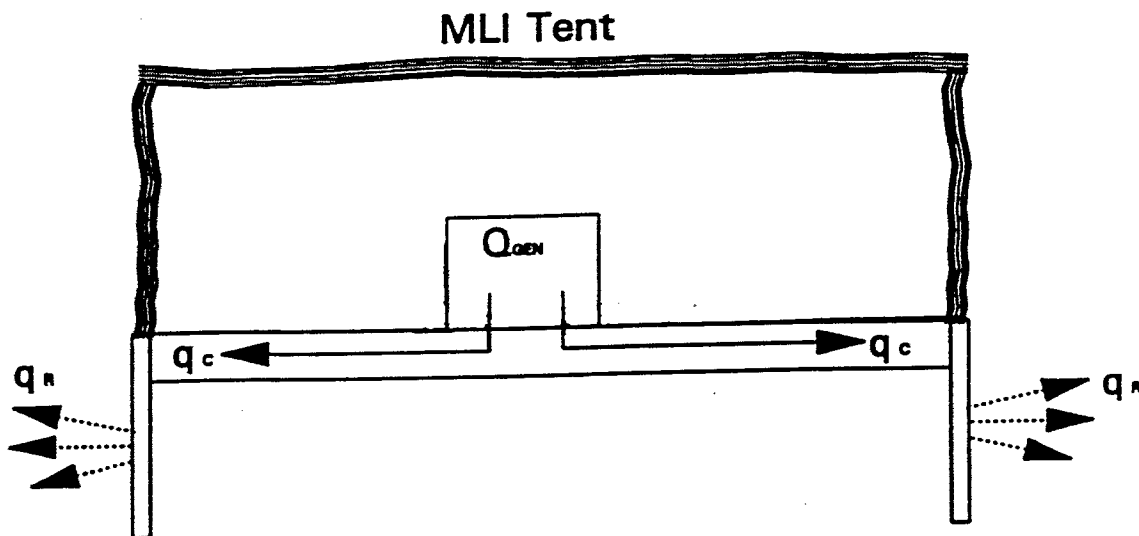

FSCM NO.	SIZE	DWG. NO.
88898	A	7345-9020
SCALE	DO NOT SCALE PRINT	SHEET 47

design placement of local radiators, if required to remove localized heat, must be coordinated with the spacecraft thermal engineer.

- b) **Central Thermal Control:** Thermal dissipation is conducted from the instrument/sensor to the observatory deck for eventual rejection to space. Candidates for central control include support electronics that have no apertures and which can be thermally decoupled from the sensor sections that require extended temperature ranges. Use of central thermal control requires approval of the spacecraft thermal engineer.
- c) **Hybrid Thermal Control:** Thermal dissipation is removed from the instrument/sensor via a combination of radiation to the environment and conduction to the observatory deck. The use of hybrid thermal control is undesirable because of analysis difficulties. Instruments desiring hybrid control must demonstrate the necessity of its use and be prepared to work very closely the spacecraft thermal engineer if its use is allowed.

In any case, the thermal design of the instruments/sensors will require cooperation between the instrument/sensor thermal engineer and the spacecraft engineer. It is important that liaison between instrument/sensor designers and the spacecraft designers begins as early in the design phase as possible.

4.4 **PAYLOAD INSTRUMENT/SENSOR SPACE ENVIRONMENT TEMPERATURE LIMITS**

The allowable instrument/sensor orbital temperature limits shall be established by the experimenter and documented in Figure 4.4-1. Instrument thermal models, delivered to the spacecraft, must include nodes for all critical temperatures defined in Figure 4.4-1. As a minimum, the following limits shall be specified at the appropriate control locations:

- a) **Operating Limits:** Temperature range within which each instrument/sensor must meet its operating specifications. For instruments utilizing Local Thermal Control, the operating limits must be specified at control surfaces, usually the radiators. Limits must also be given for critical components within the instrument and for acceptable deck interface temperatures. For instruments utilizing Central Thermal Control, operating limits must be specified at the spacecraft side of the interface between the instrument and the deck. Limits for critical components must also be specified. For instruments utilizing Hybrid Thermal Control, operating limits must be specified for all control locations and for critical components.
- b) **Survival Limits:** Widest temperature range that each instrument/sensor can undergo in an unpowered state without damage or performance degradation. Survival limits must be specified at the appropriate thermal control locations as defined above for Operating Limits.

FSCM NO. 88898	SIZE A	DWG. NO. 7345-9020
SCALE	DO NOT SCALE PRINT	SHEET 4-8

Figure 4.4-1 Instrument Temperature Limits

The SWEPAM-I shall meet its operational specification through out the normal operating range. The preferred range identifies a smaller portion of the normal range which provides improved calibration/noise figures and/or reduced component thermal stress and therefore improved reliability.

The SWEPAM-I shall be tested at a temperature less than the turn-on limit in order to demonstrate design margin. This tested range becomes the demonstrated survival range. The actual survival range is probably larger. At the same time, it is acknowledged that operationally, the turn-on limit and survival limits are really synonymous.

Temperature Limits at the E-Box base plate (all temperatures °C)

Range Definition	lower	upper
Preferred Operating Range	0	+20
Operating In Specification	-20	+45
Operating Survival Range (turn-on)	-25	+50
Non-Operating Survival Range	-30	+60

FSCM NO. 88898	SIZE A	DWG. NO. 7345-9020
SCALE	DO NOT SCALE PRINT	SHEET 14

- c) Turn-on Limits: Widest temperature range within which each instrument/sensor must be capable of turning on without damage or performance degradation of any kind. The instrument is not necessarily required to operate within design specifications at the turn-on limits. However, once the instrument is within the specified operating limits, full compliance with design specifications is required. In most cases, the turn-on temperature range should be the same as the survival temperature range.

4.5 OBSERVATORY TEST TEMPERATURE LIMITS

Observatory thermal and thermal vacuum test limits are documented in APL 7347-9007. The instruments/sensors shall survive and not suffer damage or performance degradation after exposure to the specified limits. In general, temperature variations at the interfaces of the instruments are given by the design/test limits. Under no circumstances shall the temperature on the spacecraft side of the interface be allowed to exceed the corresponding instrument interface design/test limits defined here and in section 4.2.1

4.6 TEMPERATURE SENSOR LOCATIONS

The spacecraft integration team will mount temperature sensors to the baseplate of each instrument/sensor in order to monitor the interface temperature. The temperature sensors will be provided and located by the spacecraft designers. **The location of each temperature sensor shall be depicted on the instrument/sensor interface control drawing and documented in Figure 4.6-1.**

4.7 PAYLOAD INSTRUMENT/SENSOR THERMAL MODEL ANALYSIS

4.7.1 Thermal Model

A reduced thermal model of each instrument/sensor shall be provided by the instrument/sensor thermal engineer for inclusion in the overall spacecraft thermal model. The number of nodes in each model shall be consistent with the thermal complexity. Simple systems may have as few as three nodes. The models should include nodes for all critical components. Thermal models shall be provided in the SINDA format.

After integration with the spacecraft thermal model, the reduced instrument thermal models will be used by the spacecraft thermal engineer to predict instrument temperatures. Therefore, the reduced models should correlate well with the detailed instrument thermal model in the areas of heat transfer across the spacecraft interface, heat transfer with the space environment, and critical component temperatures. In addition, detailed instrument thermal models must be validated during some phase of thermal vacuum testing. If the instrument sponsors do not require qualification testing in vacuum, then, the interfaces cannot be validated until the observatory level thermal vacuum test. At that point, each instrument risks the possibility that its interface will differ significantly from that of the thermal model. Since the instrument models will be relied upon to define thermal control requirements of the instrument deck and surrounding surfaces, a significant error in the models could limit the thermal control available during flight. **Specific instrument thermal model information is defined in Figure 4.7.1-1.**

FSCM NO. 88898	SIZE A	DWG. NO. 7345-9020
SCALE	DO NOT SCALE PRINT	SHEET 4-10

Figure 4.6-1 Location of Spacecraft Supplied Temperature Sensors

The SWEPAM-I has a single, but redundant, internal temperature monitor. The spacecraft can sample this monitor regardless of the SWEPAM-I power state. The monitor is located in the electronics box, near the spacecraft interface but also near the instrument's power converter. The approximate location of this monitor is shown in the SWEPAM-I Mechanical Interface Drawing (see Appendix A).

This monitor will very nearly reflect the interface temperature when the instrument is stable in the power-off state. Soon after power is applied, the monitor will begin to read warmer than the interface due to thermal dissipation in the power converter.

The SDT shall add any additional temperature monitors as required for the interface temperature control function. The most desirable arrangement would be to apply the additional monitors to the spacecraft rather than the instrument. However, if additional monitor(s) must be applied to the instrument, the IDT will work with the SDT to identify a suitable bonding surface and mate/de-mate plan. The SDT requires an area approximately 1"x 1" for mounting of the spacecraft temperature sensor package.

FSCM NO. 88898	SIZE A	DWG. NO. 7345-9020
SCALE	DO NOT SCALE PRINT	SHEET 4 11

Figure 4.7.1-1 SWEPAM-I Thermal Model Information

SWEPAM-I IDT shall provide a instrument thermal model directly to the spacecraft thermal engineer. The node numbers for the SWEPAM instruments shall be 600 to 699 inclusively.

FSCM NO. 88898	SIZE A	DWG. NO. 7345-9020
SCALE	DO NOT SCALE PRINT	SHEET 4-12

4.7.2 Geometry Model

Experimenters shall provide, to the spacecraft, geometric models of their instruments in SSPTA format, for inclusion in the overall spacecraft geometric model. In return, the spacecraft will -provide flux information for each surface of the model to the instrument/sensor designers for use in their detailed thermal modeling effort.

Geometric models shall be delivered to the spacecraft no later than June 7, 1993 to allow adequate time for incorporation into the spacecraft models prior to PDR. Updated models shall be delivered to the spacecraft no later than March 1, 1994 to allow adequate time for analysis prior to the spacecraft CDR.

4.8 THERMAL CONTROL DEVICES

Special thermal control devices required by an instrument shall be defined and described in the SIIS. The primary concern is for devices that will have some affect on the thermal interface between an instrument and the spacecraft.

4.8.1 Heaters

There are three classes of heaters that are of concern to the instruments/sensors aboard the ACE Observatory: interface, operational, and survival **The instrument heater capacities are the peak power requirements for the operational, interface, and survival heaters shown in Figure 4.8.1-1**

Interface heaters are mounted on the ACE experiment deck and are used to augment the instrument deck operational heaters during times when one or more instruments are turned off. The interface heaters replace some of the dissipation lost when an instrument is turned off. Sizing and placement of the interface heaters is the responsibility of the spacecraft thermal engineer. The heater power is allocated from the spacecraft power budget. The interface heater design effort cannot be completed until all of the final instrument thermal models have been incorporated into the spacecraft thermal model. The interface heaters are of primary importance to the instruments that utilize central thermal control. Instruments utilizing local thermal control are less affected by changes in deck temperature because of low thermal conduction in the interface.

The two remaining types of heaters, operational and survival, fall within the domain of the instrument thermal engineer. The instrument operational heaters are intended to support internal temperature requirements and can be used during normal instrument operation. The use of operational heaters is optional and the heater power will be allocated from the instrument power budget. Since the majority of the instruments are baselining a thermally isolated design, it may be necessary for the spacecraft to provide some additional instrument operational heater power. This will only be possible if the spacecraft deck temperature limits are as indicated in Section 4.2.1.

The ability of the spacecraft thermal engineer to provide additional operational heater power to the instruments will depend on the outcome of the overall spacecraft thermal analysis which will include all of the instrument thermal models. If additional operational heater power is required, the instrument thermal engineer must work with the spacecraft thermal engineer to define the requirement.

FSCM NO. 88898	SIZE A	DWG. NO. 7345-9020
SCALE	DO NOT SCALE PRINT	SHEET 4-13

Figure 4.8.1-1 SWEPAM-I Thermal Control Devices

Except for any interface heaters that may be required by the spacecraft to maintain the SWEPAM-I interface temperatures, the SWEPAM-I has no heaters.

FSCM NO. 88898	SIZE A	DWG. NO. 7345-9020
SCALE	DO NOT SCALE PRINT	SHEET 4 14

Additional operational heater power will only be provided if the instrument thermal engineer can show that no other reasonable means can be used to control the instrument within its operational limits. This heater power is not for use in place of operational heaters already defined in the instrument design. Finally, if the final instrument analysis shows that the additional heater power will not be used, it will be reallocated to the spacecraft heater power budget.

The instrument survival heaters support internal temperatures during periods in which the instrument is in a powered off state. However, when an instrument is off, its operational power will be reallocated to the spacecraft power budget, specifically for the observatory deck interface heaters. Since only part of the instrument power budget will be used for interface heaters, there will be power available for instrument survival heaters. However, the instrument thermal engineer must coordinate the use of internal survival heaters with the spacecraft thermal engineer. Instrument survival heater power will be charged against the spacecraft power budget but cannot exceed the instrument operational power budget less the amount reserved for interface heaters.

FSCM NO. 88898	SIZE A	DWG. NO. 7345-9020
SCALE	DO NOT SCALE PRINT	SHEET 4 15

5.0

PAYLOAD INSTRUMENT/SENSOR MAGNETIC INTERFACE REQUIREMENTS

The ACE Observatory includes a sensitive magnetometer. Residual magnetic fields from the payload instrument/sensors and the spacecraft subsystems must be kept to a minimum by using standard magnetic cleanliness guidelines which include: minimum use of magnetic materials, power feed and return line twisting, compensation techniques, grounding, battery placement and solar panels with back wiring and other magnetic field reduction techniques.

There is a goal of achieving an Observatory residual magnetic field, at the Magnetometer sensor(s) position, which is less than 0.1 nT. The goal for AC interference, at the Magnetometer sensor(s) location, is less than 0.001 nT over a frequency range of 0 to 10 Hz and the specific frequencies of 15 kHz (± 200 Hz), 30 kHz (± 200 Hz) and 60 kHz (± 200 Hz).

Guidelines for reducing magnetic fields are given in the Environmental Specification, 7345-9007.

5.1 INSTRUMENT/SENSOR DEGAUSSING

Currently, there are no plans to degauss hardware at JHU/APL prior to integration with the spacecraft.

5.2 INSTRUMENT MAGNETIC FIELDS

Any instrument/sensor which generates a magnetic field shall specify the level and nature of the field in Figure 5.2-1.

FSCM NO.	SIZE A	DWG. NO. 7345-9020
SCALE	DO NOT SCALE PRINT	SHEET 5-1

Figure 5.2-1 SWEPAM-I Magnetic Field Properties

Instrument Magnetics

The SWEPAM-I has no permanent magnets. The use of magnetic materials is limited to a few inductor cores. All connectors and mounting hardware are of materials with low residual magnetic properties. The generated field measured at 1 meter is ≤ 0.30 nT; the AC component is below detectable levels.

Instrument Degaussing

If degaussing is required the SWEPAM-I will suffer no ill effects with degaussing fields less than 100 gauss.

FSCM NO.	SIZE A	DWG. NO. 7345-9020	
SCALE	DO NOT SCALE PRINT		SHEET 5-2

6.0 PAYLOAD INSTRUMENT/SENSOR ELECTROMAGNETIC INTERFACE REQUIREMENTS

6.1 PROGRAM REQUIREMENTS

6.1.1 Objectives

All electronic components of the ACE Observatory must operate in electromagnetic harmony. The object of the Observatory EMI/EMC program is to verify compatibility of the payload sensors with each other, the spacecraft subsystems, and the launch site environment.

The Observatory shall conform to MIL-STD-461B, Part 3, Class A2a, tailored for the ACE mission. The specific requirements are given in the ACE Environmental Specification APL 7345-9007. The Observatory shall be tested in accordance with MIL-STD-462, tailored to the ACE mission.

FSCM NO. 88898	SIZE A	DWG. NO. 7345-9018
SCALE	DO NOT SCALE PRINT	SHEET 6-1

7.0

ENVIRONMENTAL INTERFACE REQUIREMENTS

The environments that the instruments/sensors will be exposed during all phases of the ACE mission, including ground handling, storage, integration, testing, transportation, launch and flight operations are described in the ACE Environment Definition, spacecraft and Observatory Test Requirements and Instrument Test Recommendations Document, APL 7345-9007. **Any deviation from the guidelines in aforementioned specification shall be presented in detail in Figure 7.0-1.** Instruments shall be designed to withstand electrostatic discharge (ESD) possible during packing and unpacking, transportation, and integration.

FSCM NO. 88898	SIZE A	DWG. NO. 7345-9020
SCALE	DO NOT SCALE PRINT	SHEET - 1

Figure 7.0-1 Deviations from ACE Environments and Test Requirements Specification

**SWEPAM-I will conform to the ACE Payload Environmental Design and Test Requirements:
ACE-CT-100-22. No exceptions taken.**

FSCM NO. 88898	SIZE A	DWG. NO. 7345-9020
SCALE	DO NOT SCALE PRINT	SHEET 7-2

8.0 PAYLOAD INSTRUMENT/SENSOR CONTAMINATION CONTROL

8.1 GENERAL

The contamination requirements for each of the payload instruments/sensors shall be documented in Figure 8.1-1. Prior to integration, the instrument/sensor experimenters shall verify the cleanliness levels of all sensitive surfaces. The test methods shall be identified by the experimenter.

The following chemicals are prohibited in the integration and Observatory test areas:

- a) Aromatic Hydrocarbons
- b) Acetone
- c) Methyl Ethyl Ketone
- d) Propyl Alcohol
- e) Xylene
- f) Acetylene
- g) Vacuum pump oil and oil vapor
- h) Ammonia
- i) Caustic or acid fumes
- j) Mercury
- k) Ionic Salts
- l) TBD.

8.2 PURGING

If required, instruments/sensors will be provided, throughout the integration and test phases at JHU/APL and the launch site, a nearly continuous flow of dry filtered nitrogen distributed through Teflon FEP tubes. Purge will be interrupted during thermal-vacuum testing and certain ground handling procedures. Instrument/sensor test teams will be notified in advance of interruptions lasting longer than the times specified in the Specific Instrument Interface Specification. Purge shall be provided until the observatory is disconnected from the umbilical at lift-off. The instrument/sensor designer is responsible for the design of the purge system within their instrument/sensor.

8.2.1 Purge Connectors

Instruments/sensors, which require continuous purging from the spacecraft purge manifold, shall use the following purge fitting: SWAGELOCK SS-400-X-X.

FSCM NO. 88898	SIZE A	DWG. NO. 7345-9020
SCALE	DO NOT SCALE PRINT	SHEET 8-1

Figure 8.1-1 SWEPAM-I Contamination Requirements

The SWEPAM-I has been designed to comply with the provisions of paragraph 8.1. The Instrument shall always be handled with cotton or ESD safe polymer gloves. If required, the instrument can be cleaned with solvent dampened, lint free wipes. Suitable solvents are isopropyl alcohol or ethyl alcohol.

FSCM NO. 88898	SIZE A	DWG. NO. 7345-9020
SCALE	DO NOT SCALE PRINT	SHEET 8-2

8.2.2 **Purge Gas Flow Rate**

Determination of the purge gas flow rate shall be the responsibility of the instrument/sensor experimenter. The necessary purge gas flow rate shall be controlled by the use of a restrictor integral with the purge connector or contained within the instrument/sensor. **Purge gas flow rate and restrictor information shall be documented in Figure 8.2.2-1.** The S/C purge manifold will be regulated at 3 psi. The maximum gas pressure is limited to 5 psi.

8.2.3 **Materials Outgassing**

Polymeric materials used in the instrument/sensor design shall conform to the requirements of the ACE Performance Assurance Implementation Requirements. **Exceptions and additions to these outgassing requirements shall be documented in Figure 8.2.3-1.**

FSCM NO. 88898	SIZE A	DWG. NO. 7345-9020
SCALE	DO NOT SCALE PRINT	SHEET 8-3

Figure 8.2.2-1 SWEPAM-I Purge Requirements

General Requirements

The SWEPAM-I will not normally require purge until just before launch. As part of the pre-launch close out procedure, the environmental seals will be removed. At that time the spacecraft shall provide the SWEPAM-I with a connection to the purge manifold and continuous purge up to umbilical separation. Prior to that time, the SWEPAM-I will have a cap on it's purge port and the spacecraft must close off the supply to the instrument.

Purge Connectors

The purge fitting on the instrument is a SWAGELOCK SS-400-X-X . The location of this fitting is shown in the instrument's Mechanical Interface Drawing (see Appendix A).

Purge Pressure and Flow Rates

The spacecraft shall maintain the pressure at the input of the instrument in the range of 3 to 5 psi. The SWEPAM-I shall provide a flow restrictor to achieve a flow rate of 0.2 l/m at 3 psi. At no time shall the supply pressure exceed 5 psi or instrument damage is possible due to over pressurization.

Purge Gasses

The purge media shall be $\geq 99.95\%$ pure nitrogen gas. The temperature of the gas shall preclude cooling the instrument below the local dew point temperature. The IDT believes a temperature range of 15 to 30 °C is easily achievable and consistent with this requirement for all environments up to launch in which the instrument will be exposed.

FSCM NO. 88898	SIZE A	DWG. NO. 7345-9020
SCALE	DO NOT SCALE PRINT	SHEET 8.4

Figure 8.2.3-1 SWEPAM-I Exceptions or Additions to General Outgassing Requirements

Materials Outgassing

The SWEPAM-I materials conform to the requirements as set forth in the Performance Assurance Requirements for the Science Payload of ACE, GSFC-410-ACE-008. No exceptions to these requirements have been identified. If any non-conforming materials are identified at a later date, the materials and waiver request status shall be included in the SWEPAM materials list.

The SWEPAM-I is not susceptible to effluents from conventional materials used in satellite structures and assemblies. However, the instrument does use plastics and surface coatings that can be damaged by exposure to some solvents commonly used in the aerospace industry. The list of such solvents include trichloroethane and ketone based solvents such as acetone.

Hazardous Materials

The SWEPAM-I contains no hazardous materials in either its flight or test configuration.

FSCM NO. 88898	SIZE A	DWG. NO. 7345-9020
SCALE	DO NOT SCALE PRINT	SHEET 8-5

9.0 PAYLOAD INSTRUMENT/SENSOR GROUND SUPPORT EQUIPMENT

9.1 GENERAL

Ground support equipment (GSE) used for integration testing and prelaunch operations is the experimenter's responsibility and shall demonstrate compliance with the provisions of this document including contamination control, ground handling and storage.

The instrument/sensor GSE shall be capable of:

- a) verifying that the instrument/sensor has survived shipment and is ready for integration.
- b) accepting and processing the Observatory telemetry and science data downlink in real time and performing engineering analysis necessary to verify the successful operation of the instrument during all levels of Observatory testing.
- c) provide any required external stimulus.

9.2 INTERFACE

All GSE interfaces between the instrument/sensor and the ACE Observatory shall be documented in Figure 9.2-1. The GSE shall not interface directly with any spacecraft subsystem. Any GSE interface with the instrument shall be buffered and not have any impact on the S/C interfaces.

9.2.1 Telemetry Interface

The ACE Observatory GSE Interface and Test Operation Control Center (ITOCC) will provide the full S/C telemetry stream to each Payload GSE.

9.2.2 Command Interface

The ACE Observatory GSE (ITOCC) will provide serial interfaces for inputs from instrument GSEs to synchronize instrument/sensor testing with the instrument/sensor stimulus configuration.

9.2.3 Sun Sensor Interface

The ACE Observatory will provide buffered outputs of the Sun Pulse and the Spin Clock for instrument/sensor GSE synchronization.

9.3 GENERAL DESIGN FEATURES

The design and material construction of the GSE should incorporate the following features:

FSCM NO. 88898	SIZE A	DWG. NO. 7345-9020
SCALE	DO NOT SCALE PRINT	SHEET 9-1

Figure 9.2-1 SWEPAM-I GSE Interface

General

The principle SWEPAM-I I&T GSE is the one computer work station shared by this instrument and the SWEPAM-E. This station will consist of a desk top computer, printer and possibly an additional disk drive. This computer will be capable of performing the Instrument post-ship test using a spacecraft simulator. This spacecraft simulator is the same one that the IDT will use for instrument level testing. The SWEPAM-I has an internal electronic calibration capability and no external stimulus is required.

Interface

The SWEPAM computer work station can be connected to the SWEPAM-I test connector through a ground isolating buffer box. No power will be provided to the instrument through this interface. Except for thermal vacuum testing where the instrument high voltage needs to be interlocked with the vacuum quality sensor at GSFC, this configuration is not normally used for I&T procedures . The buffer box and test cable are on the IDT's GSE equipment list and will be provided by the IDT as needed. The cables for the ITOCC interface are to be provided by the SDT. Access through the vacuum chamber wall and to the vacuum quality sensors shall be provided by GSFC.

Telemetry Interface

The SWEPAM computer work station shall receive and process the real-time Observatory telemetry and science data as it is sent from the ITOCC. The hardware and software interfaces are outside the scope of this document.

Command Interface

While there are no hard requirements for synchronizing this computer with the ITOCC computer, it would be very desirable for the ITOCC and all instrument GSE to have access to a common time base. The "test time" clock would be a good candidate for this since proceduralized command and data acquisition would be tagged to this clock. It would also be desirable if the SWEPAM GSE could "witness" the commands going to the instrument. This would allow the GSE to verify that the command was received by the instrument and that the instrument achieved the desired state. The hardware and software interfaces are outside the scope of this document.

Sun Sensor Interface

The SWEPAM GSE has no requirement for buffered sun pulse and spin clocks from the spacecraft C&DH components during Observatory testing. However, at some point in the test flow it will be necessary to verify the sun pulse time tagging accuracy relative to the timing of the minor frame pulse. This probably will require that the test team have access to these buffered signals but the SWEPAM GSE is probably not involved.

FSCM NO. 88898	SIZE A	DWG. NO. 7345-9020
SCALE	DO NOT SCALE PRINT	SHEET 4

- a) EMC Shielding
- b) Low Contamination Potential
- c) Easily Transportable (if necessary, provide I-bolts for the overhead crane)
- d) Ability to Test Instrument/Sensor on the Bench and After Observatory Integration.

9.3.1 Power

The instrument GSE shall not draw power from the spacecraft power systems; nor shall it provide power to the S/C unless the designer has first obtained written approval from the JHU/APL Program Office. Instrument/Sensor providers shall provide information on power requirements prior to delivery to the integration facility.

9.3.2 Identification and Marking

GSE equipment shall be clearly marked with the following information:

- a) Name of Assembly.
- b) Part number.
- c) Serial number.
- d) Manufacturer.
- e) Power requirements.
- f) Instrument name.

9.3.3 Calibration

The calibration of the GSE shall be the responsibility of the payload instrument/sensor experimenter. Spares, consumables and field replaceable critical components shall be defined and documented in the SIIS.

9.3.4 Documentation

The instrument/sensor GSE is the only equipment which is able to analyze the unique instrument/sensor data and operation characteristics. The GSE must therefore be included in the Observatory test and calibration procedures. The provider shall supply the following documentation for Observatory level testing:

- a) Specifications
- b) Set-up Procedures
- c) Safety Requirements, Operation Limits and Constraints

9.3.5 Radioactive Sources

Radioactive sources required during integrated system tests, thermal vacuum tests and pre-integration acceptance tests shall be provided by the instrument/sensor providers and shall conform to all relevant U.S. Government, State of Maryland, and JHU/APL procedures for possession and use.

FSCM NO. 88898	SIZE A	DWG. NO. 7345-9020
SCALE	DO NOT SCALE PRINT	SHEET 93

Each instrument radioactive source shall be identified by isotope name, activity, emitted particles and energy and shall be documented in Figure 9.3.5-1.

9.3.6 Thermal Vacuum Testing

Any non-flight hardware required inside the TV Chamber to support TV tests shall be approved by the spacecraft Integration and Test Engineer and shall meet the outgassing requirements of this document.

FSCM NO. 88898	SIZE A	DWG. NO. 7345-9020
SCALE	DO NOT SCALE PRINT	SHEET 9.4

Figure 9.3.5-1 SWEPAM-I Radioactive Source List

SWEPAM-I uses no radioactive test sources

FSCM NO	SIZE	DWG. NO.	
88898	A	7345-9020	
SCALE	DO NOT SCALE PRINT		SHEET
			9-5

10.0 SPACECRAFT CABLE RESPONSIBILITIES

10.1 GENERAL POLICY

Consistent with past programs, the spacecraft does NOT provide any intra-instrument cabling (between instrument components) as part of the spacecraft harness responsibility. For instruments with more than one component, the spacecraft will be responsible for positioning these components and for routing any cabling between the components. The Instrument/Sensor experimenters shall provide all connecting cabling within their instrument subsystem.

10.2 INSTRUMENT CONCERN ON INTRA-INSTRUMENT CABLING

Several instruments will have more than one component within their instrument subsystem. This particularly applies to the instruments being served by an external DPU, with the DPU functioning as one of the "components" for several instrument subsystems. Meanwhile, the deck layout will be governed by many constraints, including FOV, magnetics, center of gravity, and so on, which could force the "components" of an instrument subsystem to be nonadjacent. In addition, minor changes in positioning may be needed late in the program to accommodate things such as refinement of component mass and cg, etc., as they are received. The spacecraft is responsible for routing the cabling between instrument components when they are distributed. This routing determines the cable length which the instruments would then have to provide. Several of the instruments expressed concern over providing cables between their instrument components in this type of scenario. A request has been made for the spacecraft to provide certain flight intra-instrument cables as part of the spacecraft harness. This request is reasonable, and the spacecraft will satisfy this request, under the stated conditions below. The spacecraft also has concerns regarding this new interface, but with properly handled agreements as described below, all parties should be satisfied.

10.3 CONDITIONS FOR GENERAL POLICY EXCEPTIONS

The spacecraft can only provide flight cables under certain conditions as listed below:

- a) The spacecraft cannot provide any performance sensitive cables; these cables must be provided by the instrument/sensor experimenter. **Constraints for their use shall be documented in Figure 10.3-1.**
- b) The spacecraft will only fabricate cables for the flight harness, i.e. cables will not be provided for instrument/sensor level testing.
- c) The instrument/sensor experimenter must provide the connectors used for flight cable fabrication. This procedure will ensure the correct mating connector. Mating connectors are easily procured at the same time that the instrument connector is procured. Three additional sets of connectors, plug, jack, and backshells, shall be provided for harness spares and for the breakout box used to test the harness.

FSCM NO. 88898	SIZE A	DWG NO. 7345-9020
SCALE	DO NOT SCALE PRINT	SHEET 10-1

Figure 10.3-1 Instrument Supplied Cable Constraints

NOT APPLICABLE

FSCM NO. 88898	SIZE A	DWG. NO. 7345-9020
SCALE	DO NOT SCALE PRINT	SHEET 10-2

10.4

PROCEDURES FOR INTRA INSTRUMENT CABLING REQUESTS

A "Cabling Form" will be developed for each intra instrument flight cable to be fabricated by the spacecraft. This form will be separate from the SIISs, but will be handled by the APL ACE interface manager. This form will have two versions, first a "request" to let the spacecraft know that this cable is to be fabricated by the spacecraft. General information, as available at the time, should be included on this form, and should be submitted as soon as possible. Information to be provided on this "request" should include instrument identification, instrument components involved, cable type, cable length constraints (as available), connector type to be supplied (as available) and any other needed information. This form must then be followed much later by a "fabrication order" which must include the detailed information needed to fabricate the cable. The connectors should accompany this form. It is preferred that this information be in the form of a formal drawing; however, handwritten or hand drawn sketches will be accepted. Whatever form the final drawing takes, it must have the instrument representative's approval signature. **Status of intra instrument cabling request and form/s is shown in Figure 10.4-1**

After the cable is fabricated, it will be tested for continuity at APL to verify its compliance with the drawing. The drawing and cable will be verified with the instrument team when the instrument is delivered for Observatory integration.

FSCM NO. 88898	SIZE A	DWG. NO. 7345-9020
SCALE	DO NOT SCALE PRINT	SHEET 10-3

Figure 10.4-1 Status of SWEPAM-I Intra Instrument Cabling Request and Form/s

SWEPAM-I will not require cabling support from spacecraft personnel.

FSCM NO. 88898	SIZE A	DWG. NO. 7345-9020
SCALE	DO NOT SCALE PRINT	SHEET 10-4

11.0 INSTRUMENT/SENSOR INTEGRATION

11.1 DELIVERY

Each instrument/sensor supplier shall be responsible for the delivery of their instrument/sensor, its ground support equipment (), and the preship review documentation. The instrument/sensors and their associated equipment are delivered to JHU/APL as Government Furnished Equipment (GFE). Calibration of the is the responsibility of the instrument/sensor designer.

At JHU/APL, the instrument/sensor supplier shall be responsible for all testing prior to integration with the ACE Observatory.

JHU/APL will work with the instrument/sensor suppliers to develop integration and test plans. Instrument/Sensor suppliers will be responsible for providing Observatory level test sequences and pass/fail criterion. JHU/APL will use these data to prepare integration test plans and procedures.

11.2 INSTRUMENT/SENSOR RECEIVING/ACCEPTANCE AT JHU/APL

Each instrument/sensor shall be tested on delivery to JHU/APL. The following criteria will be used by JHU/APL for instrument/sensor acceptance.

- a) Prepare JHU/APL receiving flow card (SOR).
- b) Inspection for physical damage; document on flow card.
- c) Inspection for conformance with Interface Control Drawings; document on flow card.
- d) Record data package including handling procedures, test procedures and data; document on flow card.
- e) Instrument/sensor experimenters will perform post-shipment electrical tests to verify survival after shipment and confirm conformance to the performance specifications.
- f) JHU/APL integration and test engineers will review the instrument/sensor supplier's acceptance test data package for comparison with the data from the post-shipment electrical tests.
- g)* JHU/APL PA Manager will review the instrument/sensor documentation to ensure closure of Problem Failure Reports and acceptance test discrepancies. This review is necessary to limit the risk to other flight hardware.
- h) JHU/APL integration and test engineers will review cleanliness documentation and handling procedures.

FSCM NO. 88898	SIZE A	DWG. NO. 7345-9020
SCALE	DO NOT SCALE PRINT	SHEET 11-1

- i)* The experimenter must provide test data or verification that the instrument/sensor will survive the test environments specified in the ACE environmental specification; APL 7345-9007.
- j) Acceptance shall be documented on flow card by the system engineer, integration and test engineer and the PA Manager.

* Data may be supplied at the Pre-Ship Review.

11.3 PRE-INTEGRATION INSTRUMENT/SENSOR INTERFACE TESTING

The purpose of the pre-interface test is to verify that instrument/sensor-to-spacecraft interfaces are within specifications before the instrument/sensor is integrated with the Observatory. Of particular interest are power turn-on transients. The instrument command telemetry interfaces shall be exercised during this test to verify correct performance. These test will be performed prior to integration. Mechanical fit checks will also be performed.

11.4 COMPREHENSIVE PERFORMANCE TEST

The purpose of the comprehensive performance test is to exercise as many instrument operational modes as possible in order to verify the proper performance of the instrument/sensor prior to integration with the Observatory. The integration of the with the instruments and performance verification is the responsibility of the experimenter.

11.4.1 Comprehensive Performance Test Deliverables

The instrument/sensor provider shall provide the following instrument test deliverables prior to integration:

- a) An overall instrument/sensor test plan.
- b) Detailed test procedures.
- c) A document containing specifications, charts, graphs, indicating expected test results. This will be used to compare with the actual test results for performance verification.

These test deliverables are part of the CALTECH IDDPs.

FSCM NO.	SIZE	DWG. NO.
88898	A	7345-9020
SCALE	DO NOT SCALE PRINT	SHEET 11-2

APPENDIX A – SWEPAM-I Instrument Mechanical And Electrical Interface Drawings

FSCM NO. 88898	SIZE A	DWG. NO. 7345-9020
SCALE	DO NOT SCALE PRINT	SHEET A1

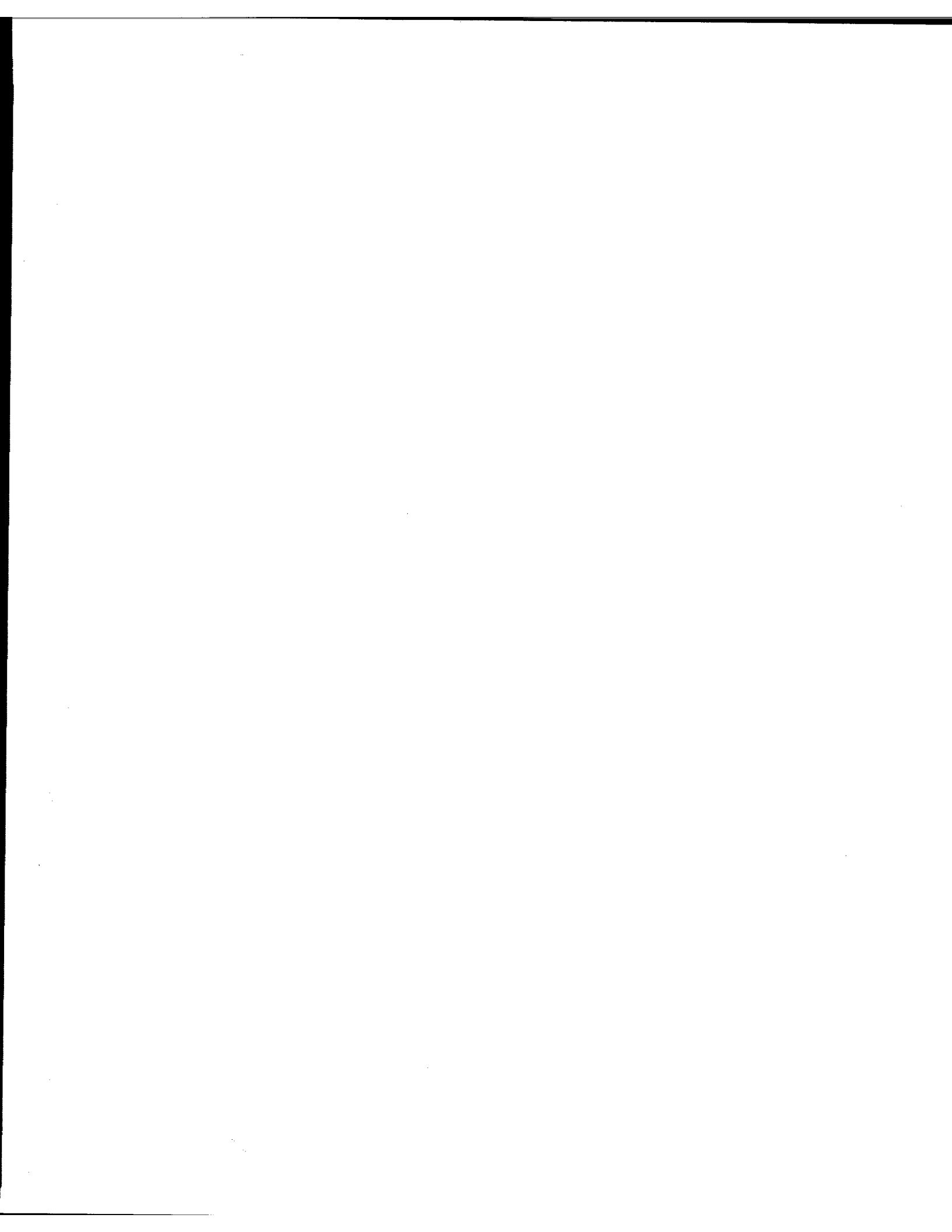

APPENDIX B-- Additional SWEPAM-I Specifications

FSCM NO. 88898	SIZE A	DWG. NO. 7345-9020
SCALE	DO NOT SCALE PRINT	SHEET B1

B1.0 GENERAL

This appendix is documentation provided by the SWEPAM IDT which does not easily fit the format of the main section of this SIIS but which is still an integral part of this interface control document. The information included here is no less binding than that provided in the main section and is subject to the same revision control.

The paragraph number conforms to that of the main section except that a letter B prefaces the number to avoid confusion when referencing the paragraph either in this document or in other documentation or correspondence. If the information provided for a given paragraph is complete in the main section, the paragraph will remain empty here in appendix B. Here, as elsewhere in this document, the Los Alamos and Sandia National Labs organization responsible for the SWEPAM-I shall be referred to as the IDT (Instrument Development Team) and the JHU/APL organization responsible for ACE spacecraft/observatory shall be referred to as the SDT (Spacecraft Development Team).

B1.1 PURPOSE OF THIS DOCUMENT

B1.2 SWEPAM-I DESCRIPTION

The ACE spacecraft serves as a stable platform providing suitable mounting, attitude control, and clear field of view for the SWEPAM-I. The spacecraft also provides the necessary power, telemetry transfer, command transfer and thermal control.

The SWEPAM-I is a single component instrument with two major assemblies; the sensor assembly and the electronics box (E-Box). Two sensor mounting brackets secure the sensor assembly to the E-Box and in turn become part of the instrument to spacecraft mounting structure. The chassis of these two assemblies are electrically isolated. The sensor assembly has a thermal blanket attachment surface which surrounds the aperture. This plate is electrically isolated from the sensor chassis and electrically connected to the E-Box.

The sensor assembly is a 105° spherical section electrostatic analyzer with 16 channel electron multipliers (CEMs) which cover a polar angle range of 90°. Measurements of the azimuth angle distribution are made by gating the CEM counters as the spacecraft spins. The analyzer is enclosed in a light tight package with an entrance aperture of 1 cm in width. The analyzer gap width is 0.28 cm and the average radius of curvature is 10 cm. The measuring range is 257ev to 35 kev. The preamplifier is an integral part of the sensor assembly.

Because the pumping speed through the analyzer aperture is not sufficient, the sensor is provided with a baffled pump out port with blackened surfaces. Both the entrance aperture and baffle must be exposed to space. To preserve the cleanliness of the sensor interior, the aperture and baffle openings will be sealed during most observatory testing. The sensor is purged with dry nitrogen prior to sealing. Prior to launch, the pump out port seal is removed and from that time on, the instrument must be on continuous purge up to umbilical separation. The sensor incorporates a pyrotechnically actuated spring loaded aperture cover (weight approx. 2 grams) which swings open while remaining attached to the instrument.

FSCM NO	SIZE	DWG. NO.
88898	A	7345-9020
SCALE	DO NOT SCALE PRINT	SHEET
		B2

The E-Box has five electronics cavities and all but one are covered and protected from handling. These cavities are;

- a.) The low voltage power supply converts spacecraft 28v into +5v, +8v, +/-6V and +/-15v for use by the various electronics.
- b.) The high voltage cavity houses two independent supplies, a 200 level -2Kv analyzer supply and a 16 level -4Kv CEM supply. The high voltage exists these cavities and are routed to the Sensor Assembly on high voltage coaxial cables. The CEM high voltage make-break jumper block is on the Sensor Assembly
- c.) The electronics suite contains the microprocessor, scalars, spacecraft C&DH interface electronics and high voltage controller modules.
- d.) The motherboard cavity is the primary wiring cavity, interconnecting the spacecraft interface connectors, power supplies, electronics and sensor. All signals enter and exit this cavity on connectors.
- e.) The sensor wiring cavity is an extension of the motherboard cavity. formed by the E-Box, Sensor Assembly and Sensor Mounting Brackets. It is via this cavity that the signals cables are routed from the E-Box to the sensor and test connector. This cavity is uncovered but when mounted to the spacecraft it becomes inaccessible.

The SWEPAM-I has four external electrical connectors; Spacecraft C&DH, spacecraft power, pyro connector and a test connector. The test connector is not normally used during testing but when it is used, either a break out box or buffer box is installed. When not in use a protective flight cover is installed. There is also a single purge connector.

B1.3 APPLICABLE DOCUMENTATION

The following documents form a part of this SIIS to the extent specified herein.

B1.3.1 NASA Documents

GSFC-410-ACE-008 Performance Assurance Requirements for the Science Payload of ACE

B1.3.2 Non Government Documents

a.) CIT documents

ACE-CT-100-20 Payload Assurance Implementation Plan
ACE-CT-100-22 Environmental Design and Test Requirements for the ACE Payload

c.) SWEPAM IDT documents

SNL-ACE004 Instrument Assurance Implementation Plan for the ACE SWEPAM

FSCM NO.	SIZE	DWG. NO.
88898	A	7345-9020
SCALE	DO NOT SCALE PRINT	SHEET
		B3

B1.3.3 Government Documents

B1.4 DOCUMENT CONFIGURATION

B1.5 DELIVERABLES

See Figure 1.5-1 in the main section.

B1.6 INSTRUMENT OPERATION AND HANDLING CONSTRAINTS AND HAZARDS

See Figure 1.6-1 in the main section.

B2.0 ELECTRICAL INTERFACE REQUIREMENTS

B2.1 GENERAL

The spacecraft provides power (+28v) and aperture door ordnance signals from the Power Switching Component (PSC) to the SWEPAM-I. The SWEPAM-I routes its telemetry and science data to the spacecraft Command and Data Handling (C&DH) component for both real-time transmission and delayed transmission through the spacecraft solid state recorder. The spacecraft C&DH error checks SWEPAM-I commands then route them to the instrument.

Figure B2.1-1 presents a functional overview of the interface between the spacecraft and the SWEPAM-I.

B2.1.1 Redundancy

The SWEPAM-I has some spare memory. Other than that, the SWEPAM-I is a single string design. For compatibility with the redundant spacecraft C&DH components, the SWEPAM-I has two C&DH interfaces designated "interface-A" and "interface-B". The design of these interfaces assures that a failure of an interface signal does not propagate to the redundant path. Except for the interface connector (J02), no electronic device are common to both interfaces.

The SWEPAM-I temperature and 5v analog monitors are simultaneously presented on both interfaces. The science data is also transmitted on both interfaces simultaneously but SWEPAM-I must be commanded to select the readout timing signals from just one of the interfaces. When power is first applied to the instrument this selection will default to interface-A but since the processor remains in reset, no science data transmission will be initiated. The command to start the processor must also select the appropriate data interface. If a processor rest should occur due to a watch dog time out, the data interface selection remains valid.

The SWEPAM-I can receive commands from either spacecraft C&DH component without any select signal. However, the instrument can not receive commands or even command timing signals simultaneously from both components. Attempts to do so could result in an inappropriate command being received and executed.

FSCM NO. 88898	SIZE A	DWG. NO. 7345-9020
SCALE	DO NOT SCALE PRINT	SHEET B4

Figure B2.1-1 Functional Block Diagram of ACE Spacecraft/Instrument Interfaces

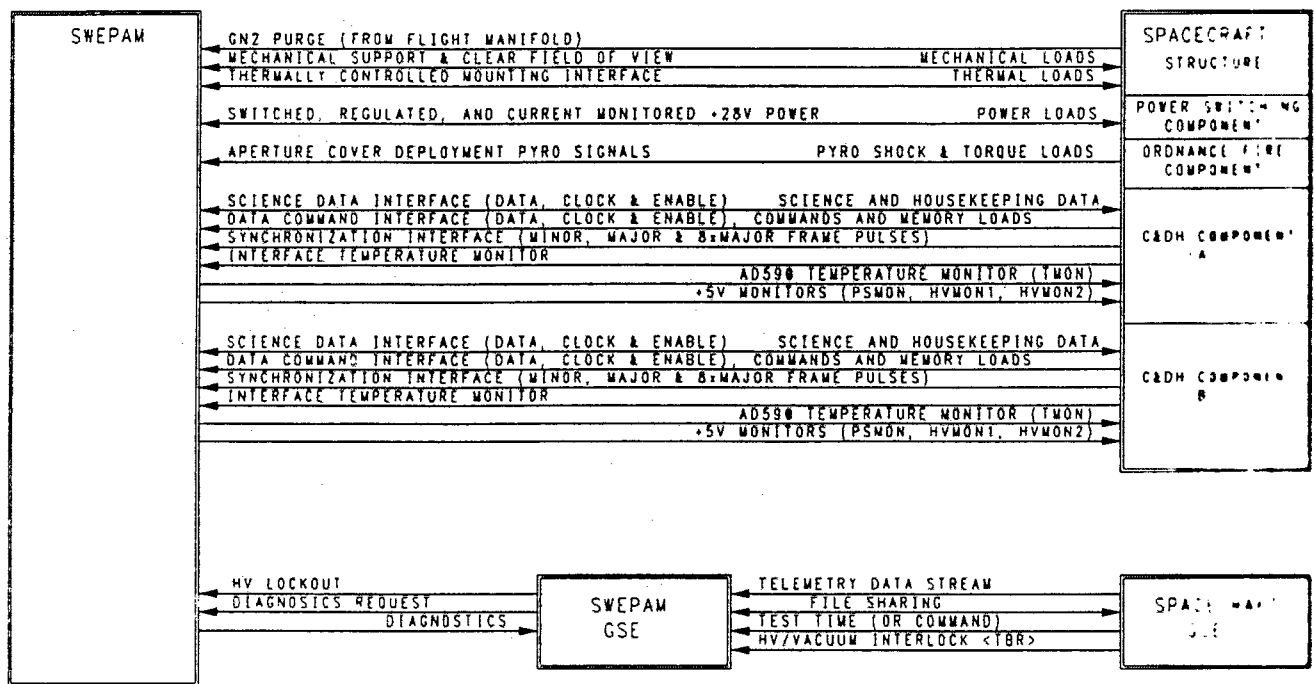

FSCM NO. 88898	SIZE A	DWG. NO. 7345-9020
SCALE	DO NOT SCALE PRINT	SHEET B5

B2.2 SYSTEM GROUNDING

B2.2.1 General

B2.2.2 Instrument/Sensor Grounding

The SWEPAM-I signal and power grounds are internally isolated from the chassis of the E-Box. The case of the sensor assembly is connected to the SWEPAM-I signal ground but isolated from the chassis of the E-Box. When mounting the SWEPAM-I to the spacecraft, it is imperative that the sensor assembly remain electrically isolated from the spacecraft structure except through the central ground point. This requires careful attention to things such as thermal blankets and non-jacketed shielded cable bundles.

B2.2.2.1 Central Ground Point (CGP)

Prior to mating the spacecraft interface connectors, the SWEPAM-I primary power ground, signal ground and E-Box chassis ground are mutually isolated. When these connectors are mated, the spacecraft shall connect the power and signal grounds to the spacecraft single point ground.

B2.2.2.2 Chassis Ground

Electrical bonding of the E-Box to the spacecraft will be achieved directly through the mounting hardware and mounting surfaces. If the thermal design dictates the use of an electrically isolating material between the spacecraft and the E-Box, a grounding straps shall be provided by the SDT to bond the instrument to the spacecraft structural ground. Since no special provisions are made for these straps, it is requested that these straps be mounted under the head(s) of the instrument to spacecraft mounting bolts. The SDT shall verify the bonding impedance as set forth in paragraph 2.2.2.2. A chassis ground pin is provided in J02 (C&DH interface connector) to facilitate this measurement.

B2.2.2.3 Primary D.C. Power Circuits Grounds

The SWEPAM-I power supply is a DC-to-DC converter. The primary power return is isolated from secondary power ground and chassis ground by at least 20 megohms <TBR> and less than 0.01 micro farad <TBR>.

B2.2.2.4 Secondary D.C. Power Circuit Grounds

The SWEPAM-I secondary power ground is also the instrument's signal ground. The secondary power ground is isolated from primary power ground and chassis ground by at least 20 megohms <TBR> and less than 0.01 micro farad <TBR>. One or more contacts on the C&DH interface connector (J02) has been designated as SWEPAM-I signal ground. The spacecraft shall connect these signal grounds to the spacecraft single point ground using the most direct routing possible. There shall be no current branches on this ground signal between the spacecraft single point ground and the SWEPAM-I interface connector. Figure 2.2.2.4-1 further documents the SWEPAM-I/Spacecraft grounding configuration.

B2.2.2.5 Signal Grounds

FSCM NO. 88898	SIZE A	DWG. NO. 7345-9020
SCALE	DO NOT SCALE PRINT	SHEET B6

See paragraph B2.2.2.4.

B2.2.2.6 Shield Grounds

On the spacecraft side of the C&DH interface connector (P02), the shields from all signals which originate from the SWEPAM-I shall be tied to a halo ring and the halo ring in turn connected to the instruments chassis ground via a contact in the SWEPAM-I interface connector (J02). The SDT shall assure that the shields of all SWEPAM-I signals which originate from the spacecraft are tied to chassis ground at the C&DH end of the interface cable.

The SWEPAM-I power connector (J01) does not provide a chassis ground contact but the shell of the connector is at chassis ground. Since power is to be distributed to the SWEPAM-I on non shielded twisted conductor cable, it is not clear that a chassis pin is really needed in the power connector.

The pyro shields will be taken through the SWEPAM-I pyro connector (J03) and connected to chassis ground near the pyros. In order to be consistent with the SWEPAM-E instrument, which has a hard requirement not to connect the pyro shields to the shell of J-03 (the spacecraft side of the SWEPAM pyro interface connector), the IDT recommends that the pyro shields of the SWEPAM-I instrument also remain isolated from the shell of P03.

B2.2.2.7 R.F. Bypassing

The SWEPAM-I does not use EMI filters on its primary or primary return power signals. There are also no plans to bypass the secondary power and power ground to chassis.

B2.2.2.8 Variations in Grounding Configuration

The SWEPAM -E conforms to the standard grounding scheme except for:

a.) the absence of a chassis ground pin on the power interface connector (ref. par. B2.2.2.6) and

b.) pyro connector shell should not be used as a tie point for the pyro shields (ref. par. B2.2.2.6).

These variations are also shown in figure 2.2.2.4-1.

B2.2.2.9 Wiring

The SWEPAM-I power and pyro connector pin out comply with the requirement for twisted primary power and twisted shielded pyro cables. Except for the two wire temperature monitors, the C&DH signals shall be single conductor shielded. The temperature monitors should be twisted shielded pair. The shields shall be tied as defined in paragraph B2.2.2.6. The IDT encourages the SDT to use shielded cable on the interface temperature monitors as well.

B2.3 POWER

FSCM NO. 88898	SIZE A	DWG. NO. 7345-9020
SCALE	DO NOT SCALE PRINT	SHEET B7

The SWEPAM-I shall accept power from the spacecraft PSC from a redundant contact power relay. This power will enter the instrument on the dedicated primary power connector (J01) on redundant contacts; 2 contacts for +28v and 2 contacts for 28V return. The spacecraft shall control and monitor the position of this relay with the currently active C&DH component.

B2.3.1 Power Interface Characteristics

B2.3.1.1 Voltage

The SWEPAM-I is compatible with the power distribution system as defined in paragraph 2.3.1.1. The spacecraft shall provide power to the SWEPAM-I such that the voltage at the input of the instrument is 28v less the line drop between the output of the spacecraft power supply and the instrument. This line drop shall not exceed 0.1 volt while the SWEPAM-I current is less than or equal to 0.121 amp even if one supply line, one relay contact and one fuse have failed open. Therefore, the spacecraft power distribution impedance can not exceed 0.826 ohms. If one assumes the impedance would double in the event of all three failures, figure 2.3.1.3-1 implies the dc impedance would still be less than 0.400 ohms so this specification should be achievable.

It is further acknowledged here that except in a bus fault condition, the spacecraft shall provide this power to the instrument interface connector with a regulation at least as good as +/-2% not including the self induced ripple due to the SWEPAM-I current variations across the impedances noted above.

B2.3.1.2 Power Allocation

The estimated SWEPAM-I nominal and peak power requirement are the same, 3.4 watt (0.121 amp @ 28V). Actual measurements will be reported when known. The SWEPAM-I has no heaters which would count against the instrument's power allocation.

B2.3.1.3 Power Bus Source Impedance

The SWEPAM-I power subsystem is compatible with the spacecraft +28v supply and bus characteristics as defined in the main section of this SIIS. This includes output impedances, regulation characteristics, voltage ripple, voltage transients and power initialization. The SWEPAM shall produce no current ripple or current transients that exceed the limits as specified in the main section of this SIIS.

B2.3.1.4 Spacecraft Power Bus Normal Operation

The SWEPAM-I shall operate within specifications as long as the S/C power bus characteristics remain as defined in paragraphs 2.3.1.4.

B2.3.1.5 Spacecraft Power Bus Abnormal Operation

The SWEPAM-I shall be able to survive without damage the abnormal S/C power bus characteristics as defined in paragraph 2.3.1.5. It is understood that all voltages given in this definition are as measured with respect to the S/C CGP and are non additive.

FSCM NO. 88898	SIZE A	DWG. NO. 7345-9020
SCALE	DO NOT SCALE PRINT	SHEET B8

The SWEPAM-I is compatible with the under voltage bus protection system as defined in the main section of this SIIS. There are no instrument configurations from which a power interruption would cause damage to the SWEPAM-I instrument.

B2.3.2 SWEPAM-I Relay Considerations

See figures 2.5.4.3.2-1 and 2.5.4.4.1-2 for the specific SWEPAM relay configurations. The contacts on the power relay shall be rated for 2.0 Amperes and those on the Pyro relays 10.0 Amperes.

B2.3.2.1 Turn-on Transients

See figure 2.3.2.1-2.

B2.3.2.2 Turn-off Transients

The SWEPAM-I design is compatible with the switched power distribution method used by the spacecraft. The induced voltages resulting from inductance have been allowed for in the design.

B2.3.3 Power Wiring

B2.3.4 Power Profiles

See figure 2.3.4-1.

B2.4 CONNECTORS

2B.4.1 General

B2.4.1.1 Equipment Interface and Test Connector Selection

See figure 2.4.1.1-1 for the general characteristics and three plates of figure 2.4.2.2-1 for the specific connector specifications for J01(Power), J02(C&DH) and J03(Pyro).

B2.4.1.2 Magnetic Properties

B2.4.2 ACE Spacecraft/Instrument Interface Connectors

B2.4.2.1 General

B2.4.2.2 Pin Assignments

See three plates of figure 2.4.2.2-1 for the specific connector specifications for J01(Power), J02(C&DH) and J03(Pyro).

B2.4.3 Test and GSE Interface Connectors

See figure 2.4.3-1.

FSCM NO. 88898	SIZE A	DWG. NO. 7345-9020
SCALE	DO NOT SCALE PRINT	SHEET B9

B2.4.4 Flight Plugs and Location

See figure 2.4.4-1

B2.4.5 Payload Stimulation and Monitor Interface

None Required.

B2.5 Command and Data Handling Subsystem

The SWEPAM-I is capable of interfacing with both strings of the spacecraft C&DH subsystem. The spacecraft design and/or operating procedures shall assure that only one string is active at any given time. Figure 2.2.2.4-1 provides an overall block diagram of the SWEPAM-I/Spacecraft electrical interface.

B2.5.1 C&DH Component Command Acceptance

The SWEPAM-I can receive commands from either C&DH component but not at the same time. The spacecraft or spacecraft operating procedures shall insure that commands, regardless of the command stream (real-time, stored or autonomous), are not transmitted to the SWEPAM-I from both C&DH components at the same time.

There are currently no operational command sequences, which if aborted would cause instrument damage. This assumes that all commands sent to the instrument were valid up to the point of interruption.

B2.5.2 Command Execution- Real-time

All SWEPAM-I commands can be sent in real-time. Due to their critical nature, some commands should only be sent in real time so that the instrument's configuration and response can be verified immediately by an operator.

B2.5.3 Command Execution-Stored

There are some operational scenarios which require SWEPAM-I commands to be stored and executed at a later time. Since the spacecraft's stored command capabilities are quite adequate, there are no plans to include stored command capabilities in the SWEPAM-I instrument. The only autonomy command identified is for over current power shut down. The limits for this are defined in figure 2.3.4-1.

B2.5.4 C&DH Subsystem Command Interface

B2.5.4.1 Logic Pulse Command

None required.

B2.5.4.2 Data Command

FSCM NO. 88898	SIZE A	DWG. NO. 7345-9020
SCALE	DO NOT SCALE PRINT	SHEET B10

See figure 2.5.4.2-2.

B2.5.4.3 Relay Command (Switched Power)

See figure 2.5.4.3.2-2

B2.5.4.4 Relay Command (Ordnance)

See figure 2.5.4.4.1-2.

B2.5.4.5 Remote Relay Command

No Requirements.

B2.6 SPACECRAFT C&DH SUBSYSTEM - DATA HANDLING PORTION

B2.6.1 Data Handling Component Interfaces

B2.6.1.1 Serial Digital - Science, Housekeeping, and Memory Dump

See figure 2.6.1.1.2-1 for the SWEPAM-I interface to the serial data portions of the C&DH subsystem. See figure 2.6.1.1.2-3 for the method used to select the active data interface.

When the SWEPAM-I is powered or after a watchdog time-out, the data output will be disabled and present "0s" to the command receivers of both C&DH components. Even after the instrument is commanded out of the HLT state, there will be a period of time before the instrument is ready to transmit data. During this time the data output remains disabled.

B2.6.1.2 Digital Telltales

No Requirements.

B2.6.1.3 0-5V Single Ended Analog Interface

B2.6.1.3.1 Description

The spacecraft shall provide the SWEPAM-I with three, redundant, 0-5v single ended analog monitor interfaces which meet the specification defined in paragraph 2.6.1.3. The data presented on these monitor channels are the SWEPAM-I state-of-health monitors. While the instrument is powered, the spacecraft shall assure that all three signals are sampled and output in both the real time (when ground contact has been made) and recorded data streams once per major frame. The digitizing resolution shall be 8 bits, therefore these three analog channels represent a 24 bits per major frame data stream. This stream is in addition to the instrument's serial data allocation.

All three channels (PSMON, HVMON1 and HVMON2) are commutated to present 8 subcommutated channels each. The commutator position is stepped by the major frame pulse and reset by the 8x major frame pulse. Into an open circuit, the output of these two monitors shall be valid within 5 milliseconds after the arrival of the leading edge of the major frame pulse at the

FSCM NO	SIZE	DWG. NO.
88898	A	7345-9020
SCALE	DO NOT SCALE PRINT	SHEET
		B11

input of the instrument. The spacecraft can sample these signals after they are valid and before the next major frame pulse.

The commutator position is not reset or held at a default position by the power-on-reset circuit. Since the SWEPAM-I can be powered asynchronously with the 8*major frame pulse, all samples of these two commutated monitors will be indeterminant until the "top" of the 8*major frame.

The +/-6 volt Aliveness positions, which were used by Ulysses to identify the commutator position, will present as much as +7 volts on the interface. Except in a fault condition all other commutation positions will never exceed +5.0V. In the event of a fault, the output buffer resistor has been selected to limit the current into the spacecraft input to preclude damage to the over voltage protection diode and propagation of the failure.

See figure 2.6.1.3.2-1 for the interface circuit of all three of these interfaces.

B2.6.1.3.2 Interface

Figure 2.6.1.1.3-1 defines the SWEPAM-I 0-5v analog monitor interface circuits. The calibration of these channels shall be unchanged should any one of the redundant interfaces become shorted to signal ground <TBR>.

B2.6.1.4 0 to +50mV Differential Analog Interface

No requirement except for the instrument buss current monitor provided by the spacecraft power distribution subsystem.

B2.6.1.5 Temperature Sensor Interface

See figure 2.6.1.5.2-2.

B2.6.1.6 Sun Pulse and Spin Clock

See figure 2.6.1.6.2-2.

B2.7 PAYLOAD INSTRUMENT SYNCHRONIZATION SIGNALS

B2.7.1 Description

The spacecraft shall provide the SWEPAM-I with redundant minor frame, major frame and 8x major frame synchronization pulses. All SWEPAM-I data formats are aligned with major frame boundaries. Data collection for these formats are synchronized to the minor frame pulse. The 8x major frame pulse synchronizes the subcommutated analog monitors as described in paragraph B2.6.1.3.1. In all cases, it is the leading edge of the pulse which is used by the instrument.

B2.7.2 Interface

See figure 2.6.1.1.2-2

FSCM NO. 88898	SIZE A	DWG. NO. 7345-9020
SCALE	DO NOT SCALE PRINT	SHEET B12

B3.0 MECHANICAL INTERFACE REQUIREMENTS

B3.1 INSTRUMENT PHYSICAL CHARACTERISTICS

See figure 3.1.3-1 for estimates of the mass properties. The mass of the flight aperture cover is so little it is in the error budget of the mass properties estimate so the change in center of mass after deployment is negligible.

B3.2 INSTRUMENT MOUNTING

See figure 3.2.2-1 for the general and specific SWEPAM-I mounting requirements.

B3.3 ALIGNMENT

See figure 3.2.2-1 for the SWEPAM-I alignment requirements. See figure 3.3-2 for the definition of the SWEPAM-I axes, field of view (FOV) and viewing constraints.

B3.4 HARNESS TIE POINTS

See figure 3.4-1.

B3.5 INSTRUMENT LOAD DESIGN

B3.6 INSTRUMENT PROTECTIVE COVERS

See figure 3.6.2-1.

B3.7 INSTRUMENT UNIQUE TOOLING AND HANDLING FIXTURES

The IDT can provide a template of the SWEPAM-I mounting foot print with mounting holes that can be used as a fit check article.

B3.8 INSTRUMENT ACCESSIBILITY

See figure 3.8-1.

B3.9 INSTRUMENT IDENTIFICATION AND MARKING

B3.10 INSTRUMENT MAINTAINABILITY

B3.11 INSTRUMENT STORAGE

B4.0 INSTRUMENT THERMAL INTERFACE REQUIREMENTS

B4.1 GENERAL

FSCM NO.	SIZE	DWG. NO.
88898	A	7345-9020
SCALE	DO NOT SCALE PRINT	SHEET
		B13

The SWEPAM-I thermal design is a collaborative effort between the SDT and the IDT. The IDT is responsible for the instrument models, internal thermal state and dynamics analysis, adjustments to thermal surfaces and validation of the model. The SDT shall maintain the latest revision of the SWEPAM-I model in the observatory thermal model. From this model the SDT should be able to establish the operating and non-operating temperatures of the SWEPAM-I for a suite of different spacecraft power states and attitude test cases. These predictions will be used by the IDT to adjust any thermal surfaces to achieve an instrument which is compatible with the ACE spacecraft. The SWEPAM-I thermal model is documented in SNL-ACE005.

B4.2 SPACECRAFT THERMAL DESIGN AND CONTROL

B4.3 SWEPAM-I THERMAL DESIGN

The SWEPAM-I thermal design is a passive design, relying on the +Z deck temperature, selected thermal surfaces and MLI blanket for thermal control. The instrument's electronics box is thermally coupled to the spacecraft +Z deck. The sensor and sensor amplifiers are electrically isolated from the electronics box resulting in a moderate amount of thermal isolation between the sensor and the electronics box. The sensor aperture is exposed to space. As such, the SWEPAM-I thermal design falls into the "Hybrid Thermal Control" category.

When the instrument is powered, there is a net thermal flow to the spacecraft even though a good deal of the instrument's self generated heat is radiated to space through the aperture. When the instrument is unpowered there is a thermal load on the spacecraft. The instrument has no operational heaters or survival heaters since the predicted operational and survival temperatures are well within the instrument and spacecraft capabilities.

The IDT shall apply all required surface coatings. The SDT shall design, manufacture and install the MLI blanket. This blanket must be designed and installed so that it does not interfere with the aperture deployment mechanism or obstruct the instrument's field of view. The blanket or blanket mounting techniques shall not induce an electrical short between the isolated sensor head and spacecraft chassis ground. For these reasons, the MLI thermal blanket design will require a great deal of cooperative interaction between the SDT and the IDT.

B4.4 INSTRUMENT SPACE ENVIRONMENT TEMPERATURE LIMITS

See figure 4.4-1.

B4.5 OBSERVATORY TEST TEMPERATURE LIMITS

B4.6 TEMPERATURE SENSOR LOCATIONS

See figure 4.6-1

B4.7 INSTRUMENT THERMAL MODEL ANALYSIS

B4.8 THERMAL CONTROL DEVICES

B4.8.1 Heaters

FSCM NO. 88898	SIZE A	DWG. NO. 7345-9020
SCALE	DO NOT SCALE PRINT	SHEET B14

See figure 4.8.1-1

B5.0 INSTRUMENT MAGNETIC INTERFACE

See figure 5.2-1

B6.0 INSTRUMENT ELECTROMAGNETIC INTERFACE REQUIREMENTS

B7.0 ENVIRONMENTAL INTERFACE REQUIREMENTS

See figure 7.0-1...No exceptions are taken.

B8.0 INSTRUMENT CONTAMINATION CONTROL

B8.1 GENERAL

See figure 8.1-1.

B8.2 PURGING

B8.2.1 Purge Connector

B8.2.2 Purge Gas Flow Rate

See figure 8.2.2-1 for a description of the SWEPAM-I purge requirements.

B8.2.3 Materials Outgassing

See figure 8.2.3...No exceptions taken.

B8.2.4 Hazardous Materials

None.

B9.0 INSTRUMENT GROUND SUPPORT EQUIPMENT

See figure 9.2-1 for a description of the GSE and interfaces. The SWEPAM-I or GSE require no radioactive sources.

The SWEPAM-I test connector includes a high voltage disable pin. This function is used during vacuum testing to interlock the high voltage supply operation to the state of the vacuum. The IDT plans to use this feature during instrument and Observatory level testing. The test connector buffer box is vacuum certified and the materials compatible with the ACE outgassing requirements. The SDT or GSFC will need to provide any thermal vacuum cable design requirements and any non-standard hermetic bulk head connectors. The IDT will manufacture and deliver the cable(s) in time for thermal vacuum test preparations.

B10.0 SPACECRAFT CABLE REQUIREMENTS

FSCM NO. 88898	SIZE A	DWG. NO. 7345-9020
SCALE	DO NOT SCALE PRINT	SHEET B15

B11.0 INSTRUMENT INTEGRATION

B11.1 DELIVERY

The IDT shall be responsible for the delivery of the SWEPAM-I and all required support material to the APL/JHU. This equipment shall be GFE to JHU/APL and as such requires the JHU/APL be accountable for the handling, storage and use of the equipment upon receipt.

B11.2 RECEIVING/ACCEPTANCE AT APL

The IDT will perform the post ship test at the JHU/APL. JHU/APL will perform any pre-integration interface tests which may still remain to be completed. After these tests are completed, the SDT shall host a pre-integration review to determine the readiness of the instrument, spacecraft, associated GSE and procedures to proceed with the integration and test of the SWEPAM-I. At this review the IDT shall present the results of the post ship test compared to the pre ship test. Any open action items left from the pre-ship review or initiated since will be reviewed and either closed before integration will be permitted to continue or added, at least in reference, to the observatories AI list for tracking.

B11.3 PRE-INTEGRATION INTERFACE TESTING

The IDT would like to perform as much of the pre-integration interface test, as defined in paragraph 11.3, prior to the instrument's acceptance test flow. This would provide time for any corrective action that might be required of the SWEPAM-I or the spacecraft without undue risk to the ACE schedule. Upon delivery and prior to the pre-integration review, those portions of the pre-integration test which could not be run earlier and any retest that might be required, shall be performed.

B11.4 COMPREHENSIVE PERFORMANCE TEST(CPT)

The IDT shall assist the SDT to integrate the SWEPAM-I CPT into the Observatory CPT. The IDT is responsible for the review of the test results and certification of the performance. The IDT has an obligation to notify the test team at the earliest possible time of a discrepancy so that the test configuration is not changed before a discrepancy review can determine the need for a retest.

FSCM NO. 88898	SIZE A	DWG. NO. 7345-9020
SCALE	DO NOT SCALE PRINT	SHEET B16