



JHU/APL
7345-9016
Rev. -
June 1996

ACE

Advanced Composition Explorer

SWIMS

Specific Instrument Interface Specification (SIIS)



The Johns Hopkins University
Applied Physics Laboratory
Johns Hopkins Road, Laurel, Maryland 20723

JC

REVISIONS				
REV.	BY & DATE	DESCRIPTION	CHECK	APPROVED & DATE



7345-9016-

PART NUMBER	SIZE	NEXT ASSEMBLY	QTY. / NA	USED ON	EFFECTIVITY-END ITEM SER. NO.	WEIGHT

DRAWN BY	SECTION	DATE
CHECK	DATE	DATE
GROUP	DATE	DATE
SYSTEM	DATE	DATE
PA ENGR	DATE	DATE
	DATE	DATE

THE JOHNS HOPKINS UNIVERSITY
APPLIED PHYSICS LABORATORY
 JOHNS HOPKINS ROAD LAUREL, MD. 20723

SWIMS
ADVANCED COMPOSITION EXPLORER
SPECIFIC INSTRUMENT INTERFACE
SPECIFICATION

RELEASE:	FSCM NO.	SIZE	DWG. NO.	REV.
<i>RK Butcher 8-13-96</i>	88898	A	7345-9016	-
SCALE	DO NOT SCALE PRINT		SHEET	ii

REVISION LOG

This log identifies the portions of this specification revised since the formal issue date.

REVISION	PAGE NUMBER	REV DATE	APPROVAL
----------	-------------	----------	----------

FSCM NO. 88898	SIZE A	DWG. NO. 7345-9016
SCALE	DO NOT SCALE PRINT	SHEET iii

TECHNICAL CONTENT APPROVAL

JHU/APL

William Cloeren 9/29/94
Prepared by
J. M. Cloeren
Spacecraft Instrument Interface Manager

CALTECH

Gerald Murphy
Gerald Murphy
ACE Payload System Engineer

M. C. Chiu
M. C. Chiu
ACE Payload System Engineer

U. I. von Mehlem
U. I. von Mehlem
Spacecraft System Engineer

INSTRUMENT

Dr. George Gloeckler
Co- Investigator

Peter Bedini 9/23/94
Payload Instrument
Interface Engineer

GSFC PROJECT OFFICE

William B. Cross 6/14/96
William Cross
ACE System Manager

John R. Thurber 6/14/96
John Thurber
ACE Observatory Manager

FSCM NO. 88898	SIZE A	DWG. NO. 7345-9016
SCALE	DO NOT SCALE PRINT	SHEET iv

TECHNICAL CONTENT APPROVAL

JHU/APL

J. M. Cloeren 9/29/94

Prepared by
J. M. Cloeren
Spacecraft Instrument Interface Manager

CALTECH

Gerald Murphy
Gerald Murphy
ACE Payload System Engineer

M. C. Chiu

M. C. Chiu
ACE Payload System Engineer

U. I. von Mehlem

U. I. von Mehlem
Spacecraft System Engineer

INSTRUMENT

Dr. George Gloeckler

Co- Investigator

Peter Bedini 9/23/94

Payload Instrument
Interface Engineer

GSFC PROJECT OFFICE

William Cross
ACE System Manager

John Thurber
ACE Observatory Manager

FSCM NO. 88898	SIZE A	DWG. NO. 7345-9016
SCALE	DO NOT SCALE PRINT	SHEET iv

**JHU/APL LEAD ENGINEERS
TECHNICAL CONTENT REVIEW**



R. F. Conde
C&DH Subsystems

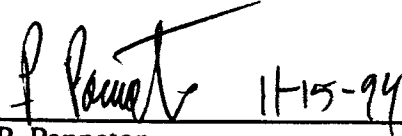

P. Panneton
Power Subsystem

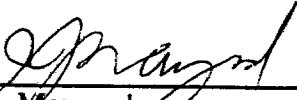

J. J. Maynard
Thermal Engineer



J. P. Staiger
I&T Engineer



C.E. Willey
Structure

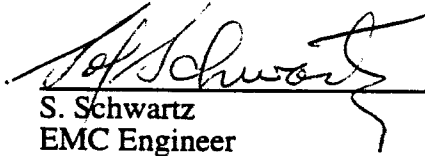

S. Schwartz
EMC Engineer

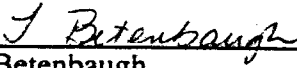

T. Betenbaugh
Stress Engineer

FSCM NO. 88898	SIZE A	DWG. NO. 7345-9016
SCALE	DO NOT SCALE PRINT	SHEET v

Table of Contents

1.0	General	1-1
1.1	Purpose Of Document	1-1
1.2	Overall Program	1-1
1.3	Applicable Documentation	1-1
1.3.1	NASA Documents	1-1
1.3.2	JHU/APL Documents	1-2
1.3.3	Government Documents	1-2
1.4	Document Configuration	1-3
1.4.1	Update and Change Control	1-3
1.5	Deliverables	1-3
1.6	Instrument Operation And Handling Constraints And Hazards	1-5
2.0	Electrical Interface Requirements	2-1
2.1	General	2-1
2.1.1	C&DH Component Redundancy	2-1
2.2	System Grounding	2-4
2.2.1	General	2-4
2.2.2	Instrument/Sensor Grounding	2-4
2.2.2.1	Single Point Ground (SPG)	2-4
2.2.2.2	Chassis Ground	2-4
2.2.2.3	Primary D.C. Power Circuit Grounds	2-4
2.2.2.4	Secondary D.C. Power Circuit Grounds	2-4
2.2.2.5	Signal Grounds	2-7
2.2.2.6	Shield Grounds	2-7
2.2.2.7	R.F. Bypassing	2-7
2.2.2.8	Variations In Grounding Configuration	2-7
2.2.2.9	Wiring	2-7
2.3	Power	2-7
2.3.1	Power Interface Characteristics	2-7
2.3.1.1	Voltage	2-7
2.3.1.2	Power Allocation	2-9
2.3.1.3	Power Bus Source Impedance	2-9
2.3.1.4	Spacecraft Power Bus Normal Operation	2-9
2.3.1.5	Spacecraft Power Bus Abnormal Operation	2-9
2.3.2	Relay Considerations	2-11
2.3.2.1	Turn-On Transients	2-11
2.3.2.2	Turn-Off Transients	2-14
2.3.3	Power Wiring	2-14
2.3.4	Instrument/Sensor Power Profiles	2-14
2.4	Connectors	2-14
2.4.1	General	2-14
2.4.1.1	Equipment Interface And Test Connector Selection	2-14
2.4.1.2	Magnetic Properties	2-14
2.4.2	ACE Spacecraft/Instrument Interface Connectors	2-17
2.4.2.1	General	2-17
2.4.2.2	Pin Assignments	2-17
2.4.3	Test And GSE Interface Connectors	2-23
2.4.4	Flight Plugs And Locations	2-23

FSCM NO. 88898	SIZE A	DWG. NO. 7345-9016
SCALE	DO NOT SCALE PRINT	SHEET vi

2.4.4.1	Special Connector Plugs	2-23
2.4.5	Payload Stimulus And Monitor Interface	2-23
2.5	Spacecraft Command And Data Handling Subsystem	2-28
2.5.1	C&DH Component Command Acceptance	2-28
2.5.2	Command Execution - Real-Time	2-28
2.5.3	Command Execution - Stored	2-28
2.5.4	C&DH Subsystem Command Interfaces	2-30
2.5.4.1	Logic Pulse Command	2-30
2.5.4.1.1	Description	2-30
2.5.4.1.2	Interface	2-30
2.5.4.2	Data Command	2-30
2.5.4.2.1	Interface	2-34
2.5.4.3	Relay Command (Switched Power)	2-34
2.5.4.3.1	Description	2-34
2.5.4.3.2	Interface	2-38
2.5.4.4	Relay Command (Ordnance)	2-38
2.5.4.4.1	Interface	2-38
2.5.4.4.1.1	Pyrotechnic Firing Voltage	2-38
2.5.4.4.1.2	Firing Circuitry	2-38
2.5.4.4.1.3	Pyrotechnic Safety Short And Arm Plugs	2-38
2.5.4.4.1.4	Pyrotechnic Circuit Shields	2-42
2.5.4.5	Remote Relay Command	2-42
2.6	Spacecraft C&DH Subsystem - Data Handling Portion	2-42
2.6.1	Data Handling Component Interfaces	2-42
2.6.1.1	Serial Digital - Science, Housekeeping, And Memory Dump	2-42
2.6.1.1.1	Description	2-42
2.6.1.1.2	Interface	2-44
2.6.1.2	Digital Telltale	2-50
2.6.1.2.1	Description	2-50
2.6.1.2.2	Interface	2-50
2.6.1.3	0-5v Single Ended Analog Interface	2-50
2.6.1.3.1	Description	2-50
2.6.1.3.2	Interface	2-50
2.6.1.4	0 To +50mv Differential Analog Interface	2-50
2.6.1.4.1	Description	2-50
2.6.1.4.2	Interface	2-55
2.6.1.5	Temperature Sensor Interfaces	2-55
2.6.1.5.1	Description	2-55
2.6.1.5.2	Interface	2-55
2.6.1.6	Sun Pulse And Spin Clock	2-55
2.6.1.6.1	Description	2-55
2.6.1.6.2	Interface	2-55
2.6.1.6.3	Sun Sensor Failure	2-63
2.7	Payload Instrument/Sensor Synchronization Signals	2-63
2.7.1	General	2-63
2.7.1.1	Available Synchronization Signals	2-63
3.0	Mechanical Interface Requirements	3-1
3.1	Instrument Physical Characteristics	3-1
3.1.1	Mass	3-1

FSCM NO. 88898	SIZE A	DWG. NO. 7345-9016
SCALE	DO NOT SCALE PRINT	SHEET vii

3.1.2	Size	3-1
3.1.3	Center Of Mass	3-1
3.1.4	Moments Of Inertia	3-1
3.1.5	Mechanical Interface Drawings	3-1
3.2	Instrument Mounting	3-4
3.2.1	General	3-4
3.2.2	Instrument Mounting Flange Specifications	3-5
3.2.3	Instrument Mounting Hardware Specifications	3-5
3.2.4	Mounting Hole Location Tolerance	3-5
3.2.5	Instrument Mounting Repeatability	3-5
3.3	Alignment	3-5
3.3.1	Definition Of Spacecraft Axes	3-5
3.3.2	Definition Of Instrument/Sensor Optical Axes	3-5
3.3.3	Alignment of Optical Axis	3-10
3.4	Harness Tie Points	3-10
3.5	Payload Instrument/Sensor Load Design	3-10
3.5.1	General	3-10
3.5.2	Load Directions	3-10
3.6	Payload Instrument/Sensor Protective Covers	3-10
3.6.1	Non-Flight Protective Covers	3-10
3.6.2	Flight Covers And Doors	3-10
3.7	Payload Instrument/Sensor Unique Tooling and Handling Fixtures	3-13
3.7.1	Optical Tooling	3-13
3.7.2	Handling Fixtures	3-13
3.8	Payload Instrument/Sensor Accessibility	3-13
3.9	Payload Instrument/Sensor Identification And Marking	3-13
3.10	Payload Instrument/Sensor Maintainability	3-13
4.0	Payload Instrument/Sensor Thermal Interface Requirements	4-1
4.1	General	4-1
4.2	Spacecraft Thermal Design And Control	4-1
4.2.1	Spacecraft-Instrument Interface Temperatures	4-3
4.3	Instrument Sensor Thermal Design And Control	4-4
4.4	Payload Instrument/Sensor Space Environment Temperature Limits	4-8
4.5	Observatory Test Temperature Limits	4-10
4.6	Temperature Sensor Locations	4-10
4.7	Payload Instrument/Sensor Thermal Model Analysis	4-10
4.7.1	Thermal Model	4-10
4.7.2	Geometry Model	4-13
4.8	Thermal Control Devices	4-13
4.8.1	Heaters	4-13
5.0	Payload Instrument/Sensor Magnetic Interface Requirements	5-1
5.1	Instrument/Sensor Degaussing	5-1
5.2	Instrument Magnetic Fields	5-1
6.0	Payload Instrument/Sensor Electromagnetic Interface Requirements	6-1
6.1	Program Requirements	6-1
6.1.1	Objectives	6-1
7.0	Environmental Interface Requirements	7-1
8.0	Payload Instrument/Sensor Contamination Control	8-1
8.1	General	8-1

FSCM NO. 88898	SIZE A	DWG. NO. 7345-9016
SCALE	DO NOT SCALE PRINT	SHEET viii

8.2	Purging	8-1
8.2.1	Purge Connectors	8-1
8.2.2	Purge Gas Flow Rate	8-3
8.2.3	Materials Outgassing	8-3
9.0	Payload Instrument/Sensor Ground Support Equipment	9-1
9.1	General	9-1
9.2	Interface	9-1
9.2.1	Telemetry Interface	9-1
9.2.2	Command Interface	9-1
9.2.3	Sun Sensor Interface	9-1
9.3	General Design Features	9-1
9.3.1	Power	9-3
9.3.2	Identification And Marking	9-3
9.3.3	Calibration	9-3
9.3.4	Documentation	9-3
9.3.5	Radioactive Sources	9-3
9.3.6	Thermal Vacuum Testing	9-4
10.0	Spacecraft Cable Responsibilities	10-1
10.1	General Policy	10-1
10.2	Instrument Concern On Intra-Instrument Cabling	10-1
10.3	Conditions For General Policy Exceptions	10-1
10.4	Procedures For Intra Instrument Cabling Requests	10-3
11.0	Instrument/Sensor Integration	11-1
11.1	Delivery	11-1
11.2	Instrument/Sensor Receiving/Acceptance at JHU/APL	11-1
11.3	Pre-Integration Instrument/Sensor Interface Testing	11-2
11.4	Comprehensive Performance Test	11-2
11.4.1	Comprehensive Performance Test Deliverables	11-2
APPENDIX A -- Specific Instrument Mechanical Interface Drawings		A-1
APPENDIX B -- Open Action Items		B-1

FSCM NO. 88898	SIZE A	DWG. NO. 7345-9016
SCALE	DO NOT SCALE PRINT	SHEET ix

1.0

GENERAL

This specification details the electrical, mechanical, thermal, and environmental interfaces between the instrument, named on the title page of this document, and the ACE spacecraft when the interface is not already defined by the ACE General Instrument Interface Specification (GIIS). The structure and section numbering of the GIIS and this document are correlated. The requirements of the GIIS apply, unless amended in the corresponding sections of the document. All instrument specific interfaces shall be documented in this specification.

1.1 **PURPOSE OF DOCUMENT**

This document specifies the interface of ACE spacecraft and the instrument named in the title. This specification assumes interface conformance with the GIIS and shall document unique information and exceptions to the GIIS. **NOTE: Specific Instrument Interface information and comments are shown in bold type and a different font.**

1.2 **OVERALL PROGRAM**

The Advanced Composition Explorer mission is designed to observe particles, of solar, interplanetary, interstellar, and galactic origins, spanning the energy range from that of the solar wind to galactic cosmic rays. Definitive studies will be made of the abundance of all isotopes from hydrogen to zinc. Experimental studies will extend the isotope abundance range to zirconium.

ACE will be a coordinated effort to determine and compare the isotopic and elemental composition of several distinct samples of matter; the solar corona, the interplanetary medium, the local interstellar medium, and galactic matter. ACE will provide the first extensive tabulation of solar isotopic abundance's based on direct sampling of solar material.

The ACE Observatory will consist of the spacecraft bus and nine science instruments and a data processing unit (S3DPU)

1.2.1 **Mission Operations**

Mission operations will be conducted by the Goddard Payload Operation Control Center (POCC). All science payload instrument mission operational constraints shall be communicated directly to the cognizant personnel at Goddard.

NOTICE: The spacecraft may be out -of -contact with ground stations for as much as 52 hours.

1.3 **APPLICABLE DOCUMENTATION**

The documents listed below were used to guide the design of the ACE Spacecraft and the payload instrumentation and therefore are referenced in this Specific Instrument Interface Specification (SIIS), as applicable.

1.3.1 **NASA Documents**

GSFC-410-ACE-005

ACE Performance Assurance Requirements

FSCM NO. 88898	SIZE A	DWG. NO. 7345-9016
SCALE	DO NOT SCALE PRINT	SHEET 1-1

GSFC-410-ACE-003
GSFC-410-ACE-004

ACE Mission Requirements Document
ACE Configuration Management Procedure

1.3.2

JHU/APL Documents

7345-9001	Design Specification for the ACE Spacecraft
7345-9002	ACE Interface Control Documentation Plan
7345-9003	APL Input to the ACE Observatory to DSN Interface Document
7345-9004	APL Input to the ACE Observatory to Launch Vehicle Interface Document
7345-9100	Spacecraft Assurance Implementation Plan
7345-9006	ACE Observatory Integration and Test Plan
7345-9007	ACE Environmental Definition, Spacecraft and Observatory Test Requirements and Instruments Test Recommendation Document (ACE Environmental Specification)
7345-9100	S/C Assurance Implementation Plan (AIP)
7345-9101	ACE Configuration Management
7345-9010	CRIS - Specific Instrument Interface Specification
7345-9011	SIS - Specific Instrument Interface Specification
7345-9012	ULEIS - Specific Instrument Interface Specification
7345-9013	SEPICA - Specific Instrument Interface Specification
7345-9014	MAG - Specific Instrument Interface Specification
7345-9015	SWICS - Specific Instrument Interface Specification
7345-9016	SWIMS - Specific Instrument Interface Specification
7345-9017	EPAM - Specific Instrument Interface Specification
7345-9018	SWEPAM-E - Specific Inst. Interface Specification
7345-9019	S3DPU - Specific Instrument Interface Specification
7345-9020	SWEPAM-I - Specific Inst. Interface Specification
7345-9102	ACE Contamination Control Plan

1.3.3

Government Documents

GSFC PPL-20	GSFC Preferred Parts List
MIL-STD-975 (Grade 2)	NASA-STD (EEE) Parts List
MIL-M-38510	Microcircuit General Specification
MIL-STD-750	Methods for Semiconductor Devices
MIL-STD-883C	Test Methods and Procedures for Microelectronics
MIL-STD-461B	Electromagnetic Emission and Susceptibility Requirements for the Control of Electromagnetic Interference
MIL-STD-462 (Notice 2)	Measurement of Electromagnetic Interference Characteristics
MIL-STD-480B	Configuration Control
NASA Pub 1124	Outgassing for Spacecraft Materials
NHB 5300.4 (3A-1)	Requirements for Soldering Electrical Connections

FSCM NO. 88898	SIZE A	DWG. NO. 7345-9016
SCALE	DO NOT SCALE PRINT	SHEET 1-2

NHB 5300.4 (1C)
 MIL-D-1000
 MIL-STD-100
 MIL-C-45662
 MSFC-SPEC-522A
 MIL-STD-1629A
 MIL-HDBK-5D

MIL-STD-889
 MIL-HDBK-17A
 MIL-HDBK-23A
 MIL-STD-1522

NSS/HP 1740.1
 MIL-B-5087B

MIL-STD-1541

DOD-E-83578A

GEVS-SE

MIL-P-55110
 MIL-STD-275
 MIL-S-19500
 MIL-STD-202

FED-STD-209

Inspection System Provisions
 Drawings, Engineering and Associated Lists
 Engineering Drawing Practices
 Calibration System Requirements
 Design Criteria for Controlling Stress Corrosion
 Failure Modes, Effects and Criticality Analysis
 Metallic Materials and Elements for Aerospace
 Vehicle Structures
 Dissimilar Materials
 Plastics for Aerospace Vehicles
 Structural Sandwich Components
 Standard General Requirements for Safe Design and
 Operation of Pressurized Missile and Space
 Systems
 NASA Aerospace Pressure Vessel Safety Standards
 Bonding, Electrical and Lightning Protection for
 Aerospace Systems
 Electromagnetic Compatibility Requirements for
 Space systems
 Explosive Ordnance for Space Vehicles, General
 Specifications for
 General Environmental Verification Specification
 for STS and ELV Payloads, Subsystems and
 Components
 Printed Wiring Boards
 Printed Wiring for Electronic Equipment
 General Specification for Semiconductors
 Test Methods for Electronic and Electrical
 Components
 Federal Standard Clean Room and Work Station
 Requirements, Controlled Environment

1.4 DOCUMENT CONFIGURATION

1.4.1 Update and Change Control

The data contained in this document represent the current definition of the ACE Spacecraft Interface characteristics and limitations. This document, after formal release, shall be revised only through the formal change control procedures as described in the APL ACE Configuration Management Plan.

1.5 DELIVERABLES

Each instrument/sensor provider shall deliver the items listed below for, or in support of, Observatory integration. Ground support equipment (GSE) consisting of hardware, software, and procedures, shall be shipped simultaneously or prior to the delivery of flight hardware. Safety rules, handling constraints and procedures, analytical models, analyses, drawings, test plans and procedures, test results, etc., shall be required prior to instrument delivery or as specified in the SIIS. **Deliverables and their due dates are listed in Figure 1.5-1.**

FSCM NO. 88898	SIZE A	DWG. NO. 7345-9016
SCALE	DO NOT SCALE PRINT	SHEET 1-3

Figure 1.5-1 SWIMS Instrument Deliverables

1. SWIMS Instrument
2. Sealed Instrument Case
3. Shipping Container (3' x 3' x 3' crate)
4. Red-tag items
 - a. four (4) venting plugs
 - b. one (1) pyro safety plug
 - c. one (1) H.V .disable plug
 - d. three (3) protective connector covers
5. Green-tag items
 - a. one (1) HV enable plug
6. Sensor cover opening tool
7. EGSE
 - a. TBD Personal Computer System
 - b. T. U. Braunschweig S/C Simulator Rack
 - c. U. Maryland Test Hardware
 - i. CAMAC crate
 - ii. CAMAC hardware modules
 - iii. power supplies
 - iv. tbd
8. Interface Control Drawings
9. Written Procedures
 - a. SWIMS Instrument Transport, Handling, and Storage Procedure
 - b. SWIMS Special Mounting Concerns
 - c. SWIMS Benchtest Procedure
 - d. SWIMS Operations Manual
 - e. SWIMS HV Test Procedure
 - f. tbd
10. Acceptance Test Data
 - a. SWIMS Electrical Test Data
 - b. SWIMS Environmental Test Data

FSCM NO. 88898	SIZE A	DWG. NO. 7345-9016
SCALE	DO NOT SCALE PRINT	SHEET 1-4

1.6

INSTRUMENT OPERATION AND HANDLING CONSTRAINTS AND HAZARDS

Each instrument/sensor experimenter shall summarize all constraints and hazards, which are applicable, to the handling and operation of their respective hardware. **These constraints and hazards shall be listed in Figure 1.6-1.**

FSCM NO. 88898	SIZE A	DWG. NO. 7345-9016
SCALE	DO NOT SCALE PRINT	SHEET 1-5

Figure 1.6-1 SWIMS Instrument Operation and Handling Constraints

1. Purging Requirements

SWIMS contains extremely sensitive microchannel plates (MCPs) that require a very clean and low-humidity environment. Substantial deviation from such an environment renders these MCPs non-flight-worthy. The most reliable way to maintain an acceptable environment for SWIMS is for it to be either under purge with clean, dry Nitrogen, or in the sealed SWIMS storage case that has been flushed and slightly overpressurized with clean, dry Nitrogen. See SWIMS Transport, Handling, and Storage Procedure for details.

2. Contamination Concerns

The SWIMS MCPs are extremely sensitive to contamination by a large number of solvents that are commonly used in a laboratory environment, such as Ammonia. Even when the instrument is under purge or in its flushed case, care should be used not to expose SWIMS to any cleaning compounds (except isopropyl alcohol) or other solutions or materials with high outgassing rates.

3. Instrument Turn On Constraints

As defined in the SWIMS Operations Manual, SWIMS should be powered-on only by trained operators and in accordance with the agreed upon turn-on procedures. If these procedures are not followed, damage will be done to the MCPs in SWIMS, and they must be replaced. In particular:

- a. *MCPs may only be powered on in high-vacuum ($10e-6$ torr). The aperture cover must be open and the chamber pressure must be $10e-6$ torr for at least 12 hours before power may be applied to the MCPs. A red-tag high-voltage disable plug will be installed in SWIMS at all times other than during vacuum tests.*
- c. *During vacuum tests, high-voltages must be turned up slowly. During vacuum tests wherein the SWIMS high-voltage power supplies are to be powered, these voltages must be turned up slowly, as detailed in the SWIMS Operations Manual.*

4. Physical Handling Concerns

The SWIMS instrument is extremely delicate, and must be handled only in accordance with all of the considerations detailed in the SWIMS Transport, Handling, and Storage Procedure. In particular:

- a. *SWIMS thermal surfaces must never be handled, even with gloves. These surfaces include MLI blankets, heaters, and special paints, and are identified on the drawing included in the above-mentioned procedure.*
- b. *The aperture cover must be opened only by a trained handler and in accordance with the cover-opening procedure included in the SWIMS Transport, Handling, and Storage Procedure. A special tool (supplied by the experimenter) must be used to open the aperture cover if it is not to be opened by firing its dimple motors (pyros).*
- c. *The replacement of the pyros must be performed only by a trained handler and in accordance with the pyro-replacement procedure included in the SWIMS Transport, handling, and Storage Procedure.*

Figure 1.6- 1 Instrument Operation and Handling Constraints (continued)

FSCM NO. 88898	SIZE A	DWG. NO. 7345-9016
SCALE	DO NOT SCALE PRINT	
		SHEET 1-6

2.0 ELECTRICAL INTERFACE REQUIREMENTS

2.1 GENERAL

The Command and Data Handling (C&DH) component receives, decodes and distributes spacecraft commands. It also receives, formats, stores, and transmits telemetry data from the instrument/sensor payloads and the spacecraft.

This C&DH subsystem provides the electrical interface between the ACE Spacecraft and the payload instruments/sensors.

Figure 2.1-1 presents a functional overview of the electrical interfaces between the spacecraft and the payload instruments/sensors.

2.1.1 C&DH Component Redundancy

The C&DH subsystem will be redundant, thus providing complete interface redundancy to all instruments/sensors. Each instrument/sensor shall provide interfaces to each of the redundant C&DH spacecraft subsystems. These instrument interfaces shall insure that a failure on one side of the interface does not propagate to or affect operation of the redundant side.

Each instrument shall provide a method by which the C&DH component with active data handling functions can be selected by ground command. The ground command may be a data command or a logic pulse command.

For example, each instrument could generate a data handling select bit that would enable the data handling, sun pulse, and spin clock interfaces from one C&DH component, and disable the data handling, sun pulse, and spin clock interfaces from the other interfaces. One way to implement the data handling select bit is with a data command. One data command bit pattern (op code) could be used to configure instrument electronics to use the data handling, sun pulse, and spin clock interfaces from one C&DH component, and another bit pattern could be used to select the data handling, sun pulse, and spin clock interfaces from the other C&DH component.

Note: Each instrument/sensor shall have provisions to monitor and accept commands from either of the redundant spacecraft command components.

FSCM NO. 88898	SIZE A	DWG. NO. 7345-9016
SCALE	DO NOT SCALE PRINT	SHEET 2-1

Figure 2.1-1 Functional Block Diagram of SWIMS Electrical Interface

ALSO SEE 7345-2218 IN APPENDIX A.

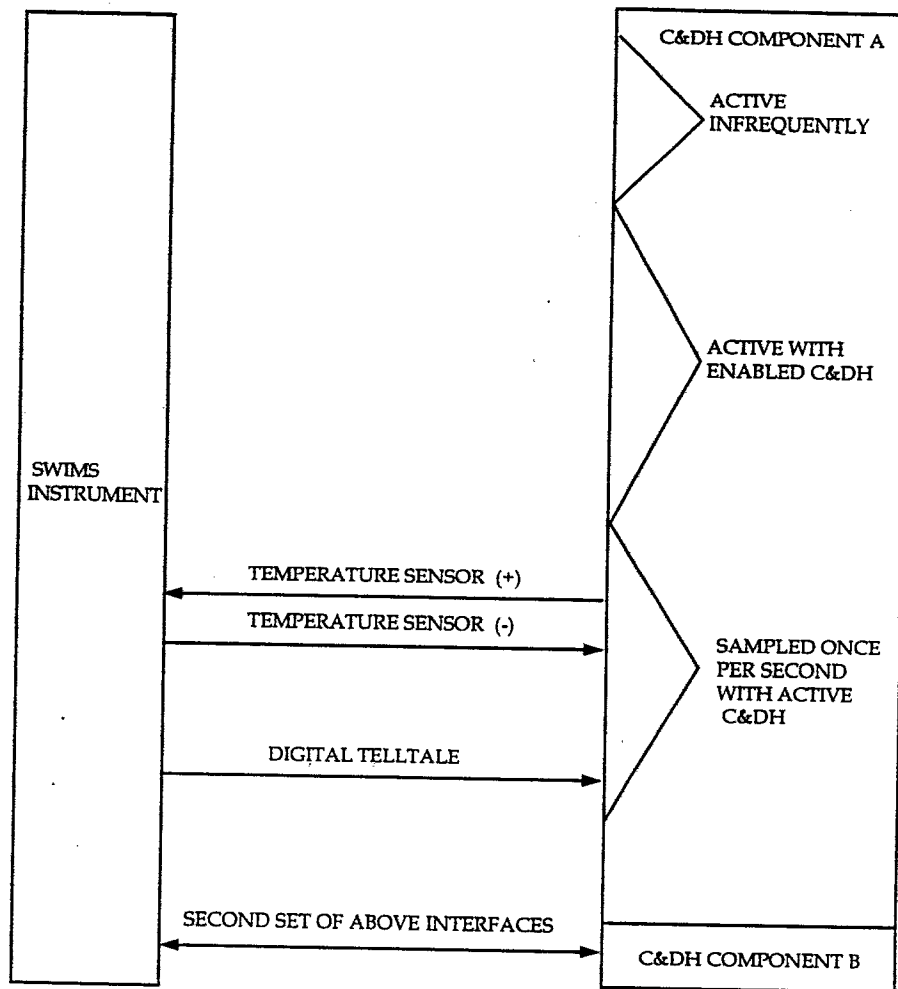

FSCM NO. 88898	SIZE A	DWG. NO. 7345-9016
SCALE	DO NOT SCALE PRINT	SHEET 2-2

Figure 2.1-1 Functional Block Diagram of SWIMS Electrical Interface
(Cont.).

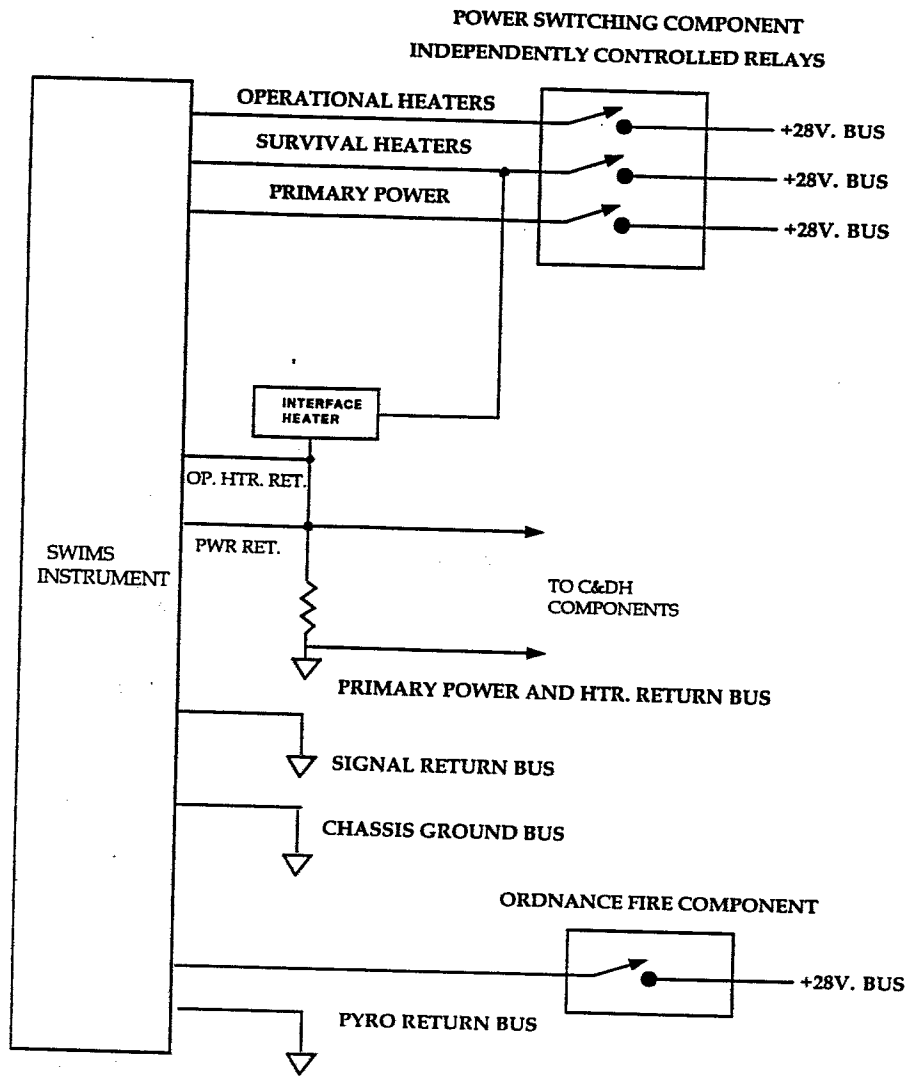

FSCM NO. 88898	SIZE A	DWG. NO. 7345-9016
SCALE	DO NOT SCALE PRINT	SHEET 2-3

2.2 SYSTEM GROUNDING

2.2.1 General

The ACE Spacecraft will employ a hybrid ground system to meet the many requirements of the Observatory and minimize electromagnetic and magnetic coupling between the payload instruments/sensors. A generalized master grounding diagram is shown in Figure 2.2.1-1. Instruments which have their secondary grounds referenced to the instrument chassis will be treated in detail in the SIIS.

2.2.2 Instrument/Sensor Grounding

2.2.2.1 Single Point Ground (SPG)

A Single Point Ground is provided on the ACE Spacecraft structure. For the payload instruments/sensors, the SPG shall be the bussing point to the spacecraft structure for primary (BUS) power returns only. The resistance between the SPG and the spacecraft structure shall not exceed 0.025 ohm.

2.2.2.2 Chassis Ground

Every instrument/sensor chassis shall be electrically bonded directly to the spacecraft structure. Instruments which are thermally isolated shall be bonded by means of grounding straps. The resistance between the instrument/sensor structures and the spacecraft structure shall not exceed 0.025 ohm. Note: S/C shall provide grounding straps. Details are shown in Figure 2.2.2.4-1.

2.2.2.3 Primary D.C. Power Circuit Grounds

Primary power returns from the instrument/sensor power conversion circuitry shall be returned to the spacecraft primary power return bus as a twisted wires through the TLM current sensing resistors.

In each instrument, the dc resistance between the primary power leads, the primary power return leads and the instrument chassis shall be not less than 1 megohm.

2.2.2.4 Secondary D.C. Power Circuit Grounds

Secondary power returns, which have been isolated from the primary power return by means of a DC-to-DC converter, shall be referenced to the spacecraft single point ground (SPG). **Instruments/sensors that must have secondary power returns common to the instrument chassis will be considered on a case-by-case basis. Specific Instrument grounding schemes are documented in Figure 2.2.2.4-1.**

Instruments/sensors that distribute power from the secondary side of a common power supply located in one component, to electronics located in another component, by means of an intra-instrument harness/cable, shall provide a secondary power return lead that isolates return currents from the spacecraft chassis.

FSCM NO. 88898	SIZE A	DWG. NO. 7345-9016
SCALE	DO NOT SCALE PRINT	SHEET 2-4

Figure 2.2.1-1 Spacecraft Master Grounding Diagram

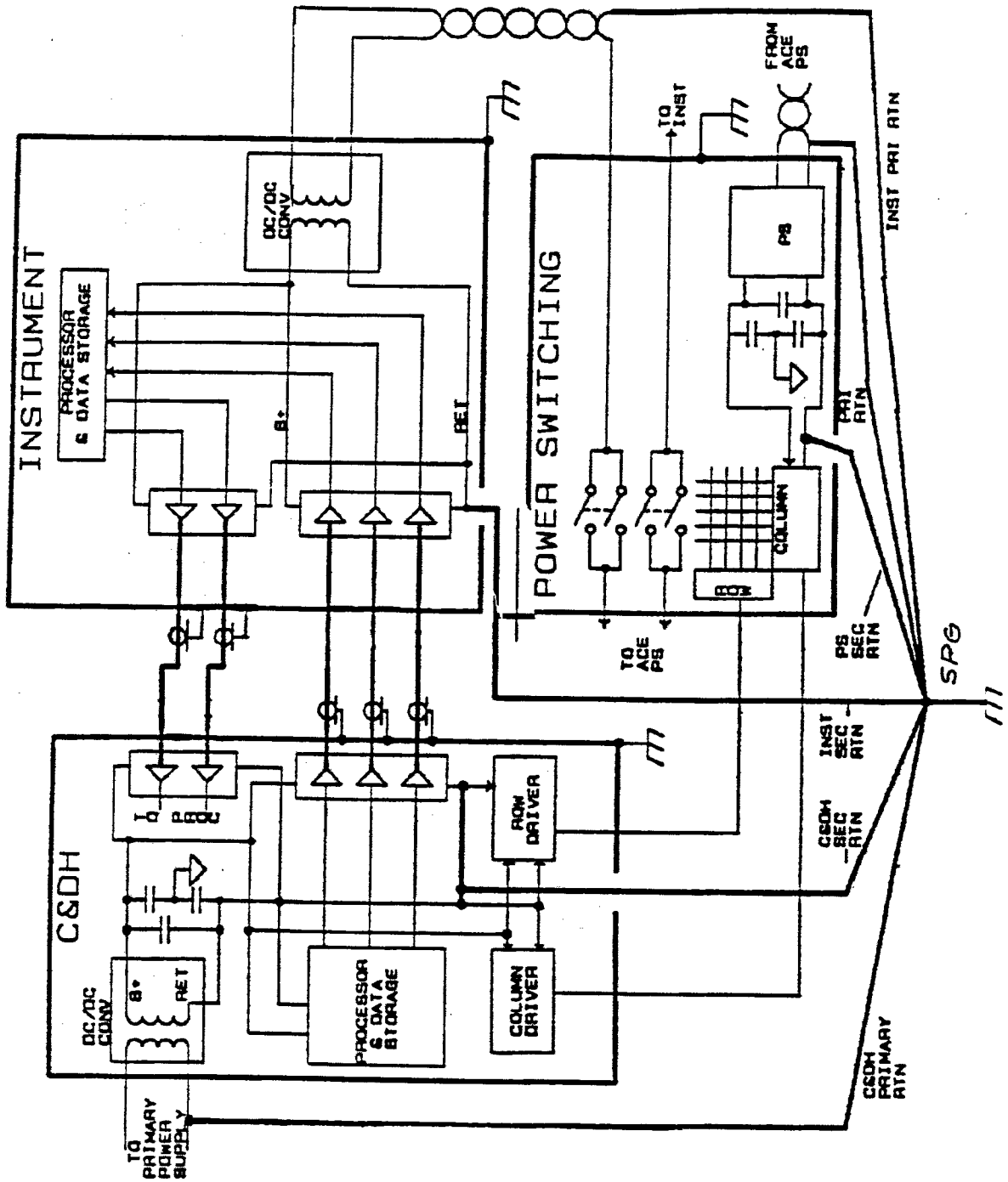

FSCM NO. 88898	SIZE A	DWG. NO. 7345-9016
SCALE	DO NOT SCALE PRINT	SHEET 2-5

2.2.2.5 Signal Grounds

The signal return conductor is the return path for all low voltage signals generated or used by the instrument/sensor. This signal return/ground shall be isolated from the primary power supply and returns leads by at least 1 megohm when not connected to the SPG.

2.2.2.6 Shield Grounds

At least one contact on each interface connector shall be provided for the purpose of shield grounding. Shields shall be grounded on the sending side only (except pyro shielding). Helo ring termination is acceptable.

2.2.2.7 R.F. Bypassing

Primary power and return lines may be bypassed to the instrument/sensor chassis with feed-through, low inductance type, capacitors. The capacitors shall be less than, or equal to .01 microfarad per lead.

2.2.2.8 Variations in Grounding Configuration

Certain variations to the grounding configuration described in the preceding paragraphs may be required to facilitate the use of existing equipment designs. These variations shall be identified in Figure 2.2.2.4-1.

2.2.2.9 Wiring

The use of twisted wire for all power and pyro lines is required. The use of the spacecraft structure as a signal return is to be avoided. Any method of wiring which will reduce stray magnetic fields should be implemented. All pyro firing wiring shall be twisted and shielded. This wiring format shall extend from the pyro connector to the pyro device. Power wiring is twisted but not shielded.

2.3 POWER

Power will be distributed to the instruments by relays in the Power Switching Component (PSC). The PSC is part of the C&DH subsystem. Each relay in the PSC may be controlled by either of the two redundant C&DH Components. Control of the relays is redundant, through the use of redundant relay coils; the relay contacts used to switch power are also redundant. The power switched by the relays will be provided over redundant wires to each instrument/sensor. Figure 2.3-1 illustrates a typical instrument/sensor power interface.

2.3.1 Power Interface Characteristics

2.3.1.1 Voltage

The spacecraft Power Bus shall provide $28V \pm 2\%$, excluding transients and ripple. Power will be provided by a two wire system (power and return) with the low side referenced to the spacecraft primary ground bus. Instrument/Sensor designers should consider

FSCM NO. 88898	SIZE A	DWG. NO. 7345-9016
SCALE	DO NOT SCALE PRINT	SHEET 2-7

Figure 2.3-1 Typical Instrument/Sensor Power Switching Interface

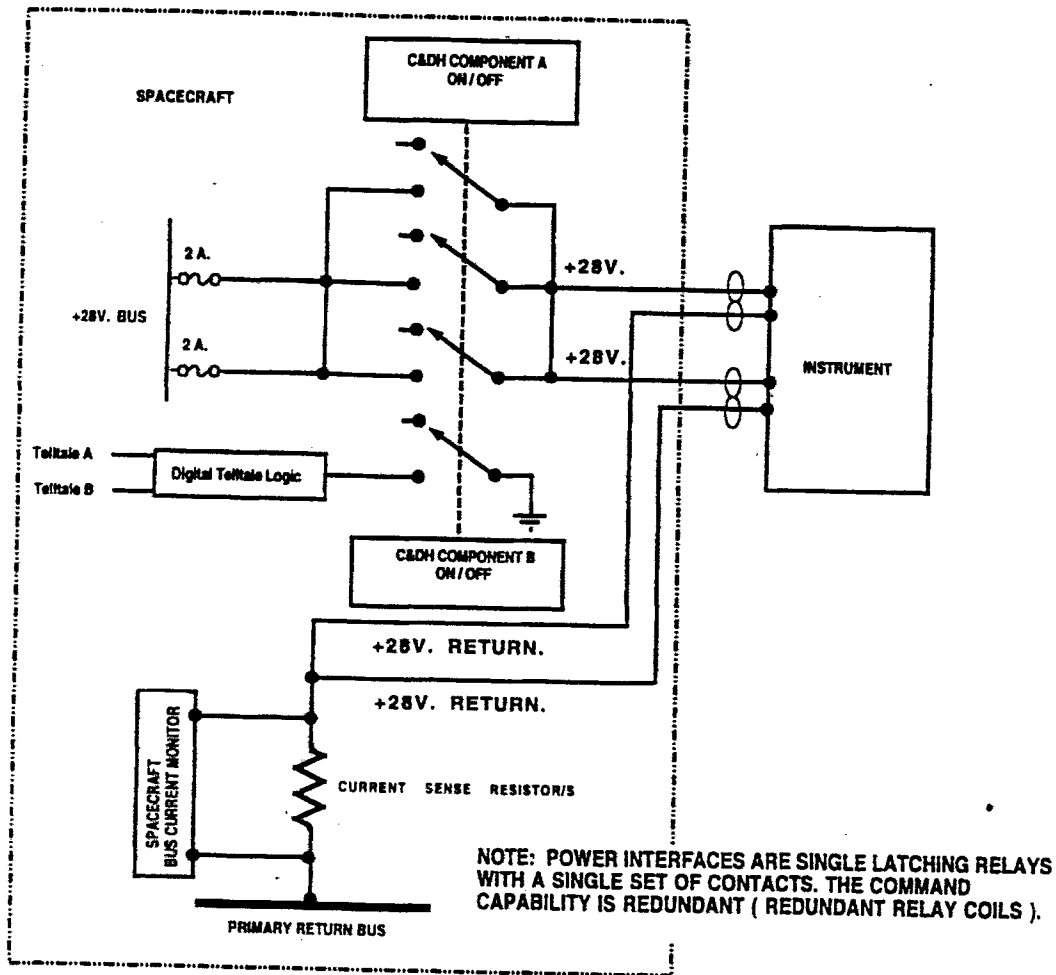

FSCM NO.	SIZE	DWG. NO.
88898	A	7345-9016
SCALE	DO NOT SCALE PRINT	SHEET
		2-8

the voltage drop at their instrument due to harness losses. The power harness shall be a minimum of two number 22 wires for both power source and return. The maximum harness length shall not exceed six feet.

2.3.1.2 Power Allocation

The power allocation for each instrument/sensor shall be established and specified in each of the Specific Instrument Interface Specifications. After agreement on the power allocations, any change in power shall require the approval of a formal change request. Power estimates shall be provided to the ACE spacecraft interface manager and designers by each of the instrument/sensor experimenters; these estimates shall include no margins.

2.3.1.3 Power Bus Source Impedance

The S/C power bus source impedance estimate is shown in Figure 2.3.1.3-1.

2.3.1.4 Spacecraft Power Bus Normal Operation

Under normal operating conditions the spacecraft power bus shall have the following characteristics:

Bus voltage: The bus shall remain at +28 VDC±2% except for load turn-on transients.

Load turn-on transient: During load turn-on, the bus shall be limited to +26.88V and shall return to +28VDC±2% within 15 milliseconds. During this time, the maximum current step change is 5A (for transponder turn-on).

Load turn-off transient: The bus turn-off transient is limited to +32V and will return to +28±2% within 15 milliseconds.

Ripple: The bus maximum ripple (at the user component) shall be less than 350mV p-p. Ripple bandwidth shall not exceed 100 MHz and shall be measured with a bandwidth >100 MHz.

Spikes: The bus maximum repetitive spike voltage shall be less than 0.5Vp-p. Short duration (less than 50ms) aperiodic transients and short duration components of long aperiodic transients shall be limited to a peak value less than three times the normal load voltage (i.e., 84V) and an impulse strength less than 140mV seconds.

2.3.1.5 Spacecraft Power Bus Abnormal Operation

In the event of an overcurrent or undervoltage condition, the bus is protected by the C&DH subsystem which removes the instruments from the bus and then, if the fault persists, removes the non-critical spacecraft subsystems. Additional protection from short circuit loads is provided by the fuses in line with all bus loads.

FSCM NO.	SIZE	DWG. NO.	7345-9016
88898	A		
SCALE	DO NOT SCALE PRINT		SHEET 2-9

Figure 2.3.1.3-1 Power Bus Source Impedance

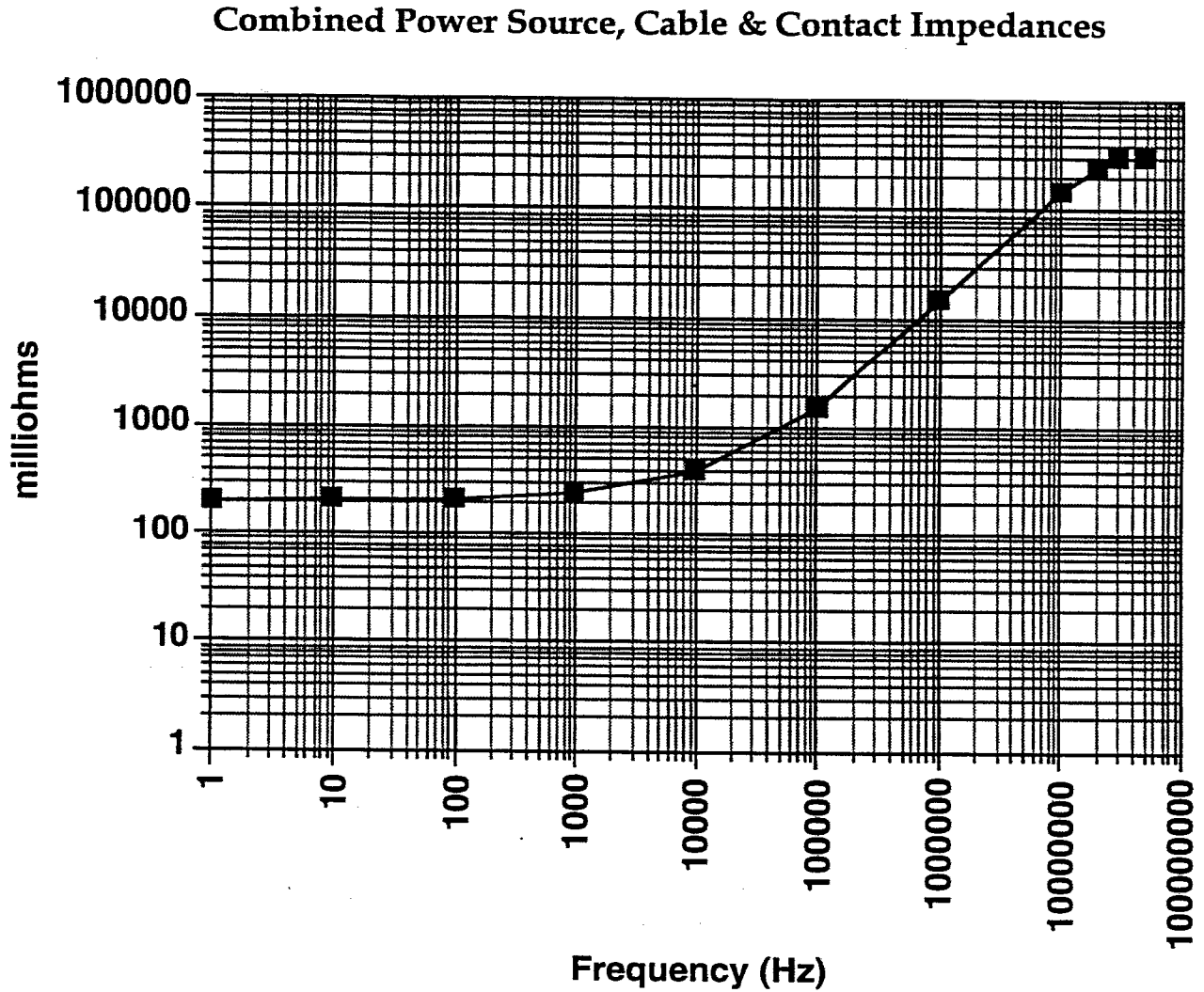

Data includes the power source, connectors, harness, relay contacts, solder joints and telemetry impedance seen by a load five feet (maximum instrument harness length) from the power source.

FSCM NO. 88898	SIZE A	DWG. NO. 7345-9016
SCALE	DO NOT SCALE PRINT	SHEET 2-10

During fault clearing, the characteristics of the bus are as follows:

Bus voltage: Fault clearing shall not exceed 10 seconds. In the event of a bus short to ground (worst case fault), the main bus voltage may be brought down to the battery voltage (approximately 19.6 volts). This assumes that the short will not cause the component fuse to open during the 10 seconds. All the non-critical loads (and the ballast (shunt resistors) loads) will be removed from the bus during the 10 seconds. When the fuse opens, only the critical spacecraft loads are powered and the bus voltage can jump to 36.6 volts for 15 milliseconds max before the bus returns to $28 V \pm 2\%$.

During integration and test, there exists a small possibility of faults which could produce a bus voltage between 0 to 30 V for 2 minutes.

Surges: Surges shall not exceed the range +18.9 to + 38 volts. The lower voltage, below the 26 v main bus trip point, shall last no longer than the time it takes to remove the non-critical loads (within 10 seconds). The upper voltage shall recover to normal operating voltage within 15 milliseconds.

2.3.2 Relay Considerations

The Power Switching and Ordnance Fire Components are made up of 2, 5 and 10 amp. rated relays. These relays come in the latching and non-latching varieties. Typically the latching relays have 2 to 4 poles and the non-latching relays have 2 to 3 poles. The number of relays in a given component is dependent on the current rating (size) of relays and the configuration called out by the users.

Each C&DH Component issues commands to the relays in the Power Switching and Ordnance Fire Component with a selectable 20, 40, 60 or 80 millisecond pulse width. This action translates to a guaranteed 10, 30, 50, or 70 millisecond non-latching relay contact closure.

2.3.2.1 Turn-on Transients

Peak turn-on transients shall not exceed the levels given in the text below and shall reach steady state operating current within 300 milliseconds. The turn-on transient maximum current rate of change shall not exceed 20mA per microsecond. See Figure 2.3.2.1-1. Specific instrument turn-on transient is shown in Figure 2.3.2.1-2.

Instruments > 1A. The initial inrush current shall not exceed 2 times the normal operating current for the first 300 ms and 1.5 times the steady state current for the remaining time not to exceed 300 milliseconds for the total transient.

Instruments < 1A. The initial inrush current shall not exceed 2 amp for the first 300ms and 1.5 amps for the remaining time not to exceed 300 milliseconds for the total transient.

FSCM NO. 88898	SIZE A	DWG. NO. 7345-9016
SCALE	DO NOT SCALE PRINT	SHEET 2-11

Figure 2.3.2.1-1 Envelope of Allowable In-rush Current

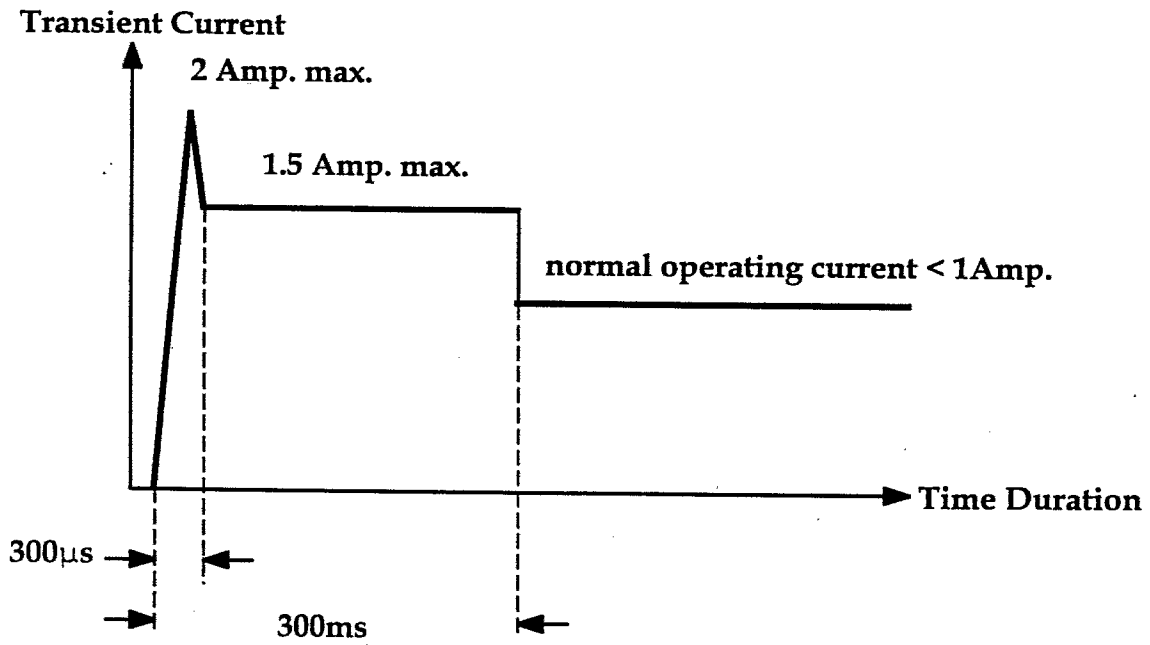
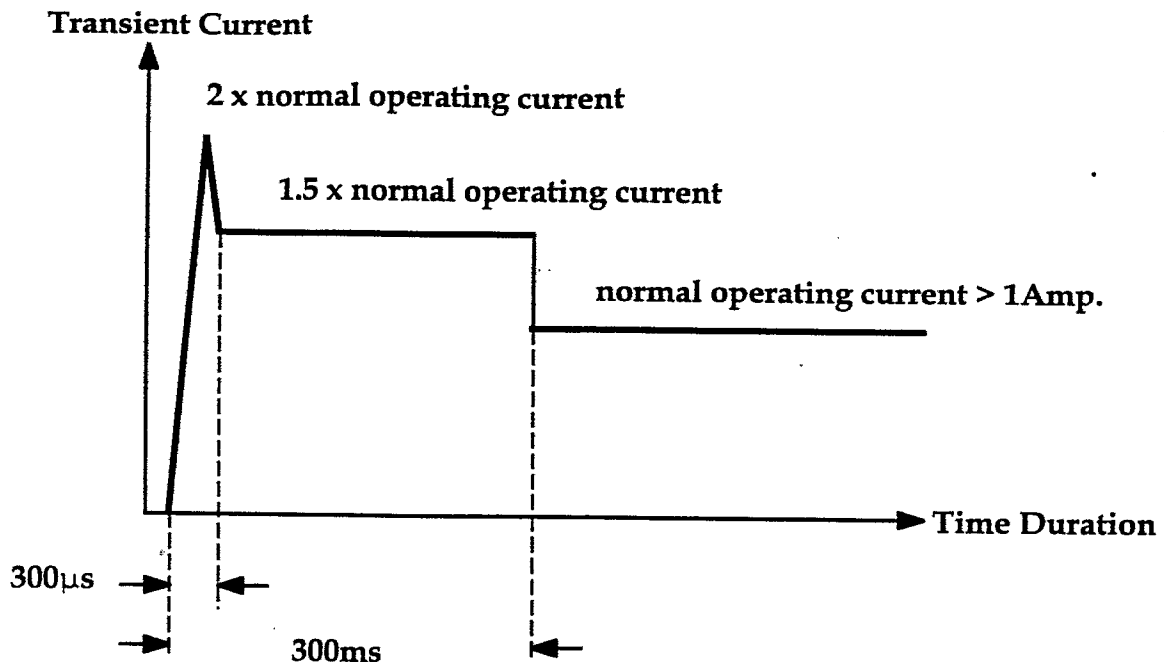

FSCM NO.	SIZE	DWG. NO.	7345-9016
88898	A		
SCALE	DO NOT SCALE PRINT	SHEET	2-12

Figure 2.3.2.1-2 SWIMS Instrument Turn-on Transient Requirements

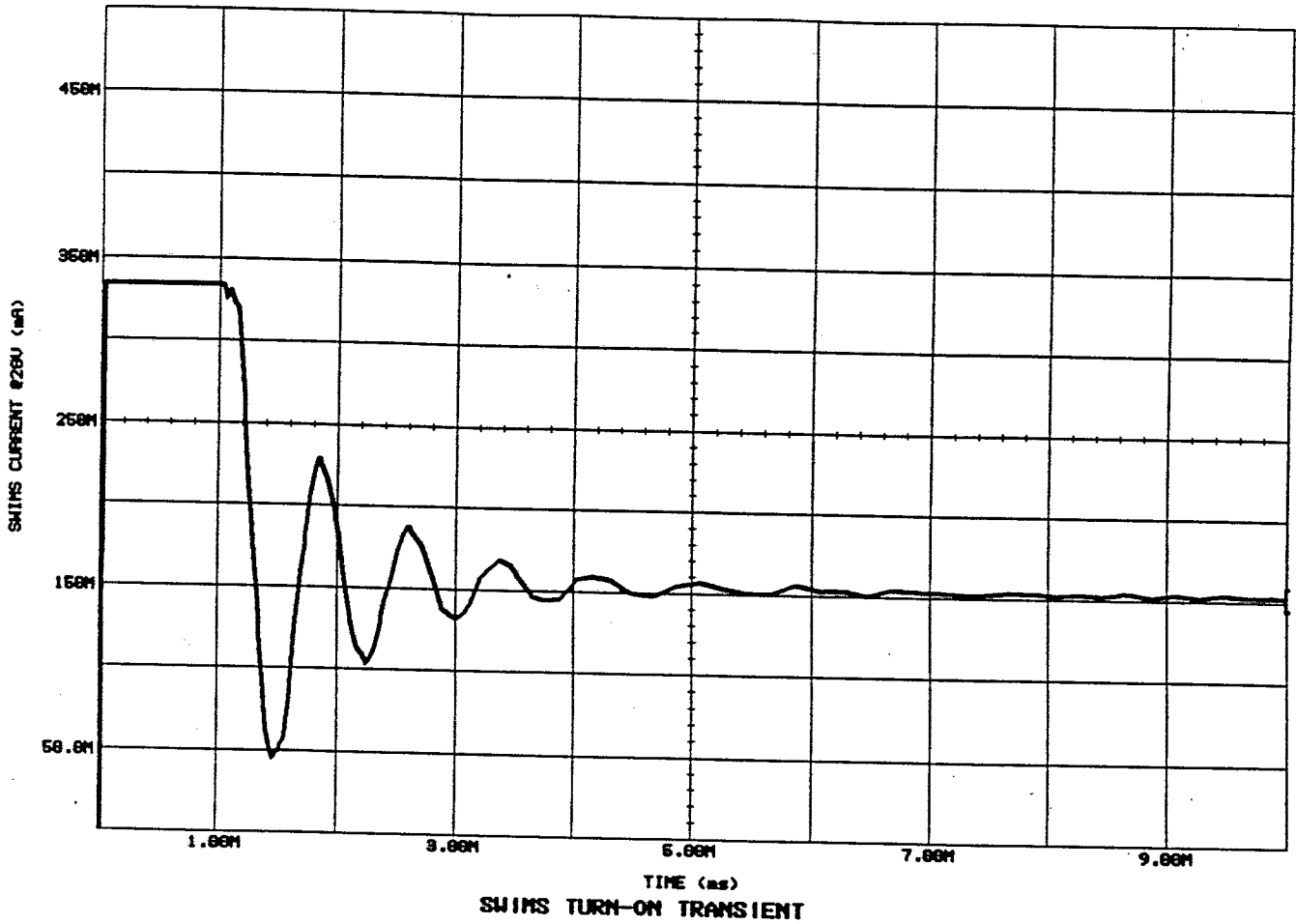

FSCM NO.	SIZE	DWG. NO.
88898	A	7345-9016
SCALE	DO NOT SCALE PRINT	SHEET 2-13

2.3.2.2 Turn-off Transients

All inductive loads associated with the users, such as coils, shall be provided with suppression circuits to prevent damage to relay contacts, due to excessive transients during power interrupts.

2.3.3 Power Wiring

Power will be distributed via unshielded twisted wires (quads) as described in Paragraph 2.2.2.3.

2.3.4 Instrument/Sensor Power Profiles

Each instrument/sensor experimenter shall provide power profiles for all normal and known abnormal operating modes of their respective equipment, including turn-on and turn-off. **The specific instrument power profiles are shown in Figure 2.3.4-1.**

2.4 CONNECTORS

2.4.1 General

2.4.1.1 Equipment Interface and Test Connector Selection

Interface and test connectors shall be Aerospace/Military designs for severe environmental applications. In order to minimize program connector types and reduce cost, it is desirable that standard connectors be used for all new equipment designed for the ACE program.

Preferred types are:

- a) Rectangular connectors meeting the requirement of GSFC S-311-P-407, S-311-P-409, or S-311-P-10. (HD and HDD "D" type connectors)

If an instrument/sensor experimenter uses a connector not listed above, the instrument/sensor experimenter shall provide JHU/APL mating connectors for all interfaces with the spacecraft. The experimenter shall supply all mating connectors which do not directly interface with the spacecraft no matter what connector type is used. (See also Section 10.) **Specific instrument connector data are shown in Figure 2.4.1.1-1.**

2.4.1.2 Magnetic Properties

The payload instrument/sensor interface connectors shall be made of non-magnetic materials in order to limit magnetic contamination of the ACE Observatory. **Exceptions shall be noted in Figure 2.4.1.1-1.** Samples of non-conforming connectors shall be provided for magnetic testing.

FSCM NO. 88898	SIZE A	DWG. NO. 7345-9016
SCALE	DO NOT SCALE PRINT	SHEET 2-14

Figure 2.3.4-1 SWIMS Power Profile

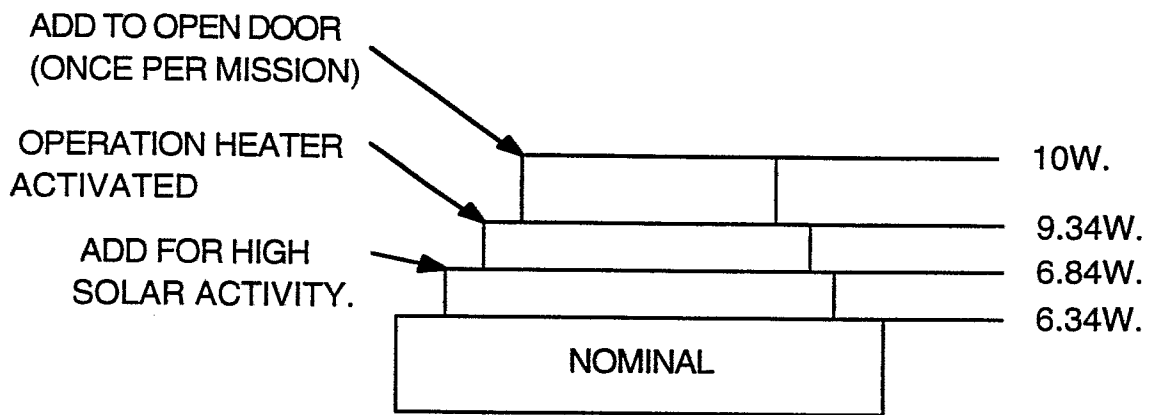

NOTE:
 THE DATA ABOVE IS FOR INFORMATION AND PLANNING PURPOSES. PAYLOAD INSTRUMENT POWER DATA ARE CONTAINED AND CONTROLLED IN THE CALTEC DOCUMENT ACE-CT-100-40. THIS DOCUMENT SHALL BE CONSULTED FOR CURRENT POWER LEVELS.

FSCM NO. 88898	SIZE A	DWG. NO. 7345-9016
SCALE	DO NOT SCALE PRINT	SHEET 2-15

Figure 2.4.1.1-1 SWIMS Connector Data

CONNECTOR	TYPE	DESCRIPTION	NAME
A0410-J01	DEM-9P	9 PIN MALE	PYRO
A0410-J02	311P407-2P-B-12	26 PIN MALE	POWER
A0410-J03	MDM-15P	15 PIN MALE	H.V. SAFE
A0410-J04	MDM-25P	25 PIN MDM	DATA (S3DPU)

FSCM NO. 88898	SIZE A	DWG. NO. 7345-9016
SCALE	DO NOT SCALE PRINT	SHEET 2-16

2.4.2 ACE Spacecraft/Instrument Interface Connectors

2.4.2.1 General

The following guidelines shall be followed for all instrument/sensor connectors which interface with the spacecraft subsystems.

- a) Instrument/sensor power and interface connectors shall be located and spaced so that they can be readily and safely mated and demated during the integration and test phases of the program.
- b) Primary Bus Power feed and return interfaces shall be contained in a separate male connector. In the event that this requirement cannot be met, all power and return interfaces shall be in the same connector.
- c) Multiple connectors shall be of different sizes or shall be uniquely keyed in order to minimize mating errors.
- d) All interface connectors shall be uniquely identified. J-numbers shall be assigned by the instrument/sensor experimenter.
- e) Connector covers shall be provided by the instrument/sensor experimenter for all connectors which do not interface with the spacecraft during flight.
- f) Connectors which use crimped contacts shall have the spare and unused pin locations populated.
- g) Torque requirements for installation of all interface connectors, protective covers, or flight plugs shall be defined by the instrument/sensor experimenter and documented by connector number in this SIIS. Preferred connectors are exempt.

2.4.2.2 Pin Assignments

The instrument/sensor experimenter shall identify pin assignments for all instrument/sensor interfaces with the spacecraft. **Instrument pin assignments are documented in Figure 2.4.2.2-1.** The following are connector pin assignment guidelines:

- a) Redundant wires and connector pins shall be used for all primary bus power inputs and returns.
- b) Pin assignments shall be made in a manner that will reduce signal crosstalk.
- c) Signal and signal returns shall be located on adjacent pins to facilitate wire twisting and shielding.

FSCM NO. 88898	SIZE A	DWG. NO. 7345-9016
SCALE	DO NOT SCALE PRINT	SHEET 2-17

Figure 2.4.2.2-1 SWIMS/Spacecraft Interface Connector Pin Assignments

SWIMS Pyro Connector, A0410-J01

<i>Pin</i>	<i>Function</i>
1	Pyro Power # 1
2	
3	Shield
5	PyroPower # 2 - Return
6	Pyro Power # 1 - Return
7	Shield
8	
9	Pyro Power # 2

FSCM NO. 88898	SIZE A	DWG. NO. 7345-9016
SCALE	DO NOT SCALE PRINT	SHEET 2-18

Figure 2.4.2.2-1 SWIMS/Spacecraft Interface Connector Pin Assignments
(cont.)

SWIMS Power Connector, A0410-J02

<i>Pin</i>	<i>Function</i>
1	N.C.
2	N.C.
3	+28V. Primary Power #2
4	Signal Ground #1
5	+28V. Survival Heater Power
6	N.C.
7	Cover Telltail #2
8	Temp. Sense #2 (+)
9	N.C.
10	N.C.
11	+28V. Primary Power #1
12	Primary Power Return # 2
13	+28V. Op. Htr. Pwr.
14	Sur. Heater Power Return
15	Signal Ground #2
16	Temp. Sense #1 (+)
17	Temp. Sense #2 (-)
18	N.C.
19	N.C.
20	Primary Power Return # 1
21	N.C.
22	Op. Heater Power Return
23	N.C.
24	Cover Telltail #1
25	Temp. Sense #1 (-)
26	N.C.

FSCM NO. 88898	SIZE A	DWG. NO. 7345-9016
SCALE	DO NOT SCALE PRINT	SHEET 2-19

**Figure 2.4.2.2-1 SWIMS/Spacecraft Interface Connector Pin Assignments
(cont.)**

IINTENTIONALLY BLANK

FSCM NO. 88898	SIZE A	DWG. NO. 7345-9016
SCALE	DO NOT SCALE PRINT	SHEET 2-20

**Figure 2.4.2.2-1 SWIMS/Spacecraft Interface Connector Pin Assignments
(cont.)**

INTENTIONALLY BLANK

FSCM NO. 88898	SIZE A	DWG. NO. 7345-9016
SCALE	DO NOT SCALE PRINT	SHEET 2-21

**Figure 2.4.2.2-1 SWIMS/Spacecraft Interface Connector Pin Assignments
(cont.)**

INTENTIONALLY BLANK

FSCM NO. 88898	SIZE A	DWG. NO. 7345-9016
SCALE	DO NOT SCALE PRINT	SHEET 2-22

2.4.3 Test and GSE Interface Connectors

Electrical interfaces required by an instrument/sensor for special test purposes, at the Observatory level, shall have a separate connector from those which interface with the spacecraft. **These direct access connectors shall be the responsibility of the instrument/sensor designer and shall be identified in Figure 2.4.3-1 if the connector is necessary for spacecraft integration.** All test connectors shall be readily accessible at the Observatory level. These test connectors should be female. All associated test harnesses shall be removed before flight. These connectors shall be covered before flight and when not in use (green tag item).

2.4.4 Location and Function of "Red Tag" and "Green Tag" Items

Items requiring installation or removal prior to launch shall be identified and the locations specified in Figure 2.4.4-1. Items shall be supplied by the Experimenter and shall be accessible at the Observatory level. "Tag" items shall be color coded as follows: NONFLIGHT -- RED; FLIGHT -- GREEN.

2.4.4.1 Special Connector Plugs

Special plugs such as high voltage enable, disable, etc. may be used to control a component prior to launch. **These plugs shall be identified in Figure 2.4.4.1-1** These plugs shall be color coded as follows: NONFLIGHT -- RED; FLIGHT -- GREEN.

2.4.5 Payload Stimulus and Monitor Interface

When required by the payload, stimulus and monitor interfaces shall be provided for the payload instruments through the spacecraft umbilical connector. **These interfaces shall be identified in Figure 2.4.5-1 and are the responsibility of the instrument/sensor experimenter.** The number of these interfaces is severely limited and will require negotiation with the spacecraft.

All umbilical level interfaces shall be buffered to prevent damage to the spacecraft in the event of problems which may occur on the umbilical lines or within support equipment.

FSCM NO. 88898	SIZE A	DWG. NO. 7345-9016
SCALE	DO NOT SCALE PRINT	SHEET 2-23

Figure 2.4.3-1 SWIMS Test and GSE Interface Connector Information

Not Applicable

FSCM NO. 88898	SIZE A	DWG. NO. 7345-9016
SCALE	DO NOT SCALE PRINT	SHEET 2-24

Figure 2.4.4-1 Location and Use of SWIMS "Red Tag"/ "Green Tag" Items

Non-Flight Protective Covers/Plugs "Red Tag Items"

a) Instrument delivered with "Red Tag" cover on A0410-J03, High Voltage Enable Connector. See SWIMS Mechanical Interface Drawing for location. A30001; Sheet 3.

b) Instrument delivered with four (4) vent plugs installed. See SWIMS Mechanical Interface Drawing for location. A30001; Sheets 1 and 3.

Flight Covers "Green Tag Items"

High Voltage Enable Plug, mates with A0410-J03

FSCM NO. 88898	SIZE A	DWG. NO. 7345-9016
SCALE	DO NOT SCALE PRINT	SHEET 2-25

Figure 2.4.4.1-1 SWIMS Special Connectors/Plugs

NOT APPLICABLE

FSCM NO. 88898	SIZE A	DWG. NO. 7345-9016
SCALE	DO NOT SCALE PRINT	SHEET 2-26

Figure 2.4.5-1 Payload Stimulus and Monitor Interfaces with the S/C through the Umbilical Connector

NONE REQUIRED

FSCM NO. 88898	SIZE A	DWG. NO. 7345-9016
SCALE	DO NOT SCALE PRINT	SHEET 2-27

2.5 Spacecraft Command and Data Handling Subsystem

The spacecraft Command and Data Handling (C&DH) Subsystem consists of two C&DH Components, a Power Switching Component, an Ordnance Fire Component, and two data recorders (see Figure 2.5-1 for the C&DH subsystem block diagram). Each C&DH component is part of one of two "strings" of spacecraft components. Each string includes a command receiver, telemetry transmitter, Sun Sensor, and C&DH component. Control of the Power Switching component and Ordnance Fire Component is cross-strapped to both C&DH components. The two Data Recorders are cross-strapped to both strings. Operationally, only one of the strings will be used unless a failure occurs in that string. A failure would be detected by the mission operations center, not autonomously detected onboard. Each instrument must be aware which string is active.

2.5.1 C&DH Component Command Acceptance

Both C&DH components are always capable of executing commands; typically, only one component will be used to execute commands. Each C&DH component receives telecommand frames from the ground. Each telecommand frame contains one or more instrument or spacecraft commands. It is only possible to address a telecommand frame to one of the two C&DH components, therefore only one C&DH component at a time will execute and output uplinked commands. Telecommand frames are checked for errors before any command in the frame is executed. If any error is found, the entire telecommand frame is rejected. An uplink protocol is used to prevent a telecommand frame from being processed if the previous telecommand frame was rejected. Therefore, execution order of a sequence of commands can be guaranteed, both within a telecommand frame and for a command sequence that extends over multiple telecommand frames. In addition to error detection at the telecommand level, individual commands also contain an error detection code. A command will not be executed if an error is detected.

2.5.2 Command Execution - Real-time

A telecommand frame can contain a combination of commands that are to be executed immediately and commands that are to be stored for future execution. Commands that can be executed immediately upon reception by the C&DH component are known as real-time commands.

2.5.3 Command Execution - Stored

Three types of stored commands can be specified: Time Tagged, Autonomy, and Block commands. A Time Tagged command is stored for execution at a specific spacecraft time count. It is stored in C&DH memory with an associated time tag. When the current spacecraft time count matches the stored time tag, the command is executed. Time tagged commands are scanned once a second. An Autonomy command is stored for execution based on the value of a particular byte of housekeeping telemetry. An autonomy command is stored with a rule. The rule contains a pointer to a specific byte of telemetry, and a comparison of that byte of telemetry to a fixed value or range. If the comparison becomes true, the autonomy command associated with the rule is executed. Autonomy rules are evaluated once per second. The rule can be required to be true multiple times before the command is executed. Autonomy commands, including the telemetry byte pointer and comparison value(s), can be reloaded by

FSCM NO. 88898	SIZE A	DWG. NO. 7345-9016
SCALE	DO NOT SCALE PRINT	SHEET 2-28

Figure 2.5-1 C&DH Subsystem Block Diagram

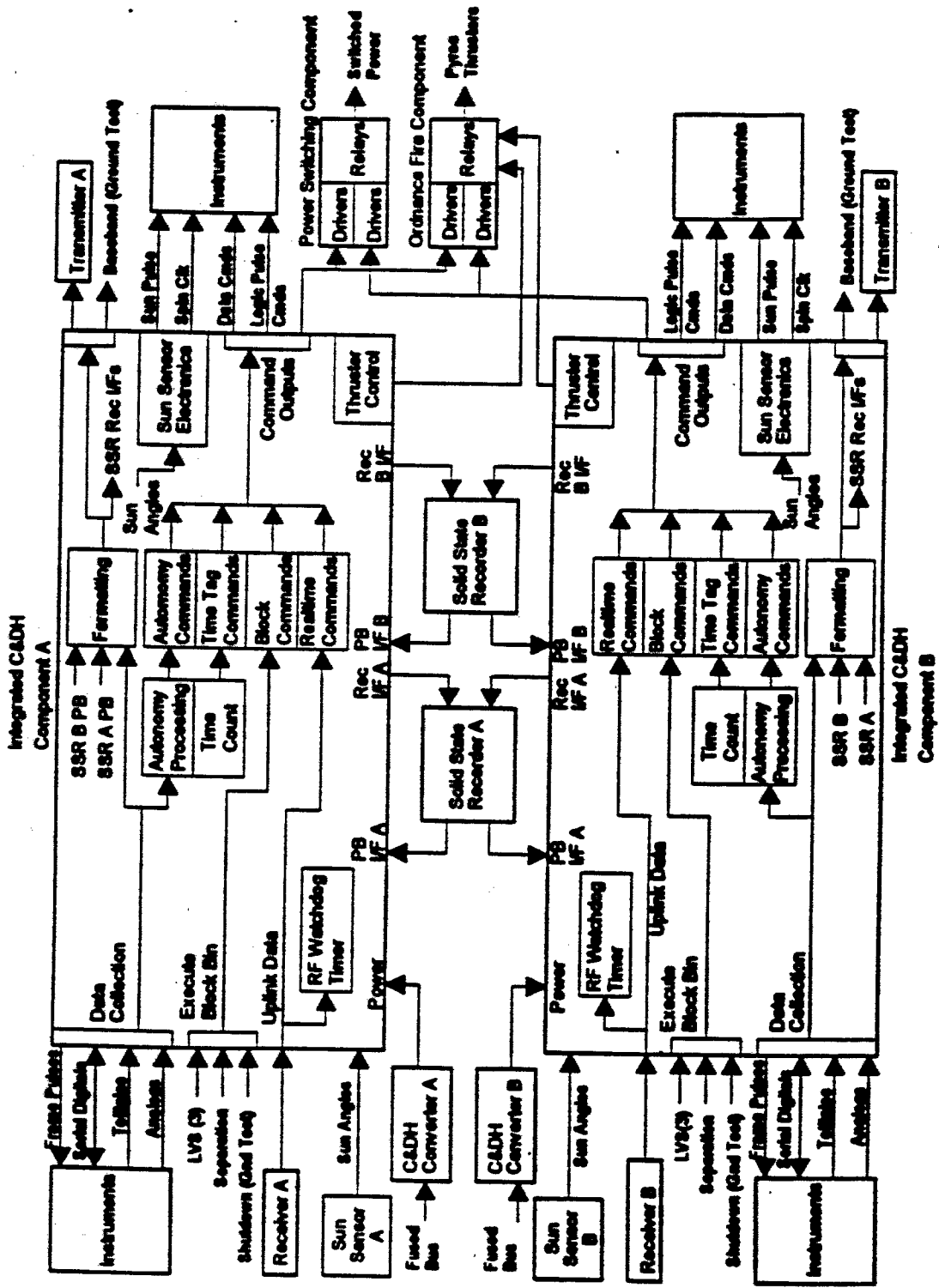

FSCM NO.	SIZE	DWG. NO.
88898	A	7345-9016
SCALE	DO NOT SCALE PRINT	
	SHEET	2-29

ground command. Finally, a Block command can be stored as a part of a group of commands. Blocks allow for sequences of greater than one command to be executed based on a single event. Commands in a block are executed based on the execution of a Block Bin Execute command, or in special cases in response to an event such as Low Voltage Sense. A Block Bin Execute command can itself be a real-time, block time tagged, or autonomy command.

2.5.4 C&DH Subsystem Command Interfaces

The C&DH Subsystem provides four types of command interfaces. These are the Logic Pulse, Data, Relay and Remote Relay command interfaces. The Logic Pulse and Data Command interfaces are duplicated on each C&DH Component and the user needs to accommodate the redundant interfaces. Care should be taken with instrument input design, because both command interfaces are powered, in the high impedance off state, throughout the ACE mission. In the case of instruments with largely CMOS circuits, this can mean that parts of the instrument could be powered from sneak paths through diodes to the rails of the input buffers. The recommended first circuit should be used to ensure compatibility with the C&DH components.

2.5.4.1 **Logic Pulse Command**

The Logic Pulse interface provides a 40-millisecond transistor switch closure to ground. An instrument should always listen to the Logic Pulse interfaces from both C&DH components, although only one is active at a time. The low power circuit suggested for the user makes use of the CD4050 with a small hysteresis feedback resistor. The CD4050 is suggested due to the lack of input diodes to the power rail. A filter is suggested to reduce the interfaces susceptibility to noise.

2.5.4.1.1 **Description**

The Logic Pulse command provides a 40-millisecond transistor switch closure to ground. A logic pulse timing diagram is shown in Figure 2.5.4.1.1-1.

2.5.4.1.2 **Interface**

The standard interface is shown in Figure 2.5.4.1.2-1. The instrument shall include a separate interface for each C&DH Component. The components used to implement the interfaces to each of the C&DH Component shall be physically distinct and separate; no single part shall serve both redundant circuits. **Specific instrument logic pulse interface is shown in Figure 2.5.4.1.2-2.**

2.5.4.2 **Data Command**

The Data Command provides variable length data to the instruments. An output data length from 8 to 4096 bits in multiples of 8 bits is acceptable. Note: no header or checksum is added to the data by the C&DH component; the C&DH component acts as a bent-pipe. The gated output clock sets the data rate at $1200 \pm 3\%$ bits per second. Consecutive data command outputs may follow as close as one millisecond, longer time intervals are possible. An instrument should always listen to the data command interfaces from both of the C&DH components although only one is active at a time.

FSCM NO.	SIZE	DWG. NO.
88898	A	7345-9016
SCALE	DO NOT SCALE PRINT	SHEET
		2-30

Figure 2.5.4.1.1-1 Logic Pulse Command Timing

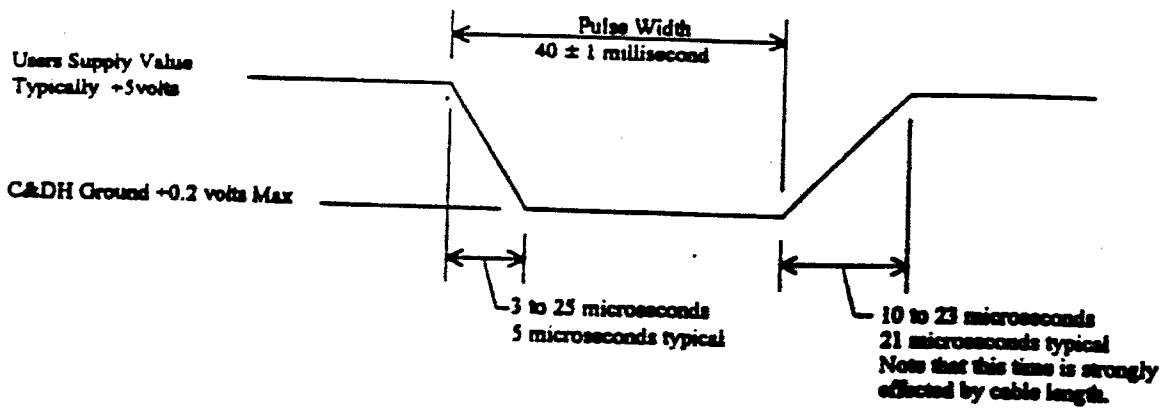

FSCM NO. 88898	SIZE A	DWG. NO. 7345-9016
SCALE	DO NOT SCALE PRINT	SHEET 2-31

Figure 2.5.4.1.2-1 Logic Pulse Interface

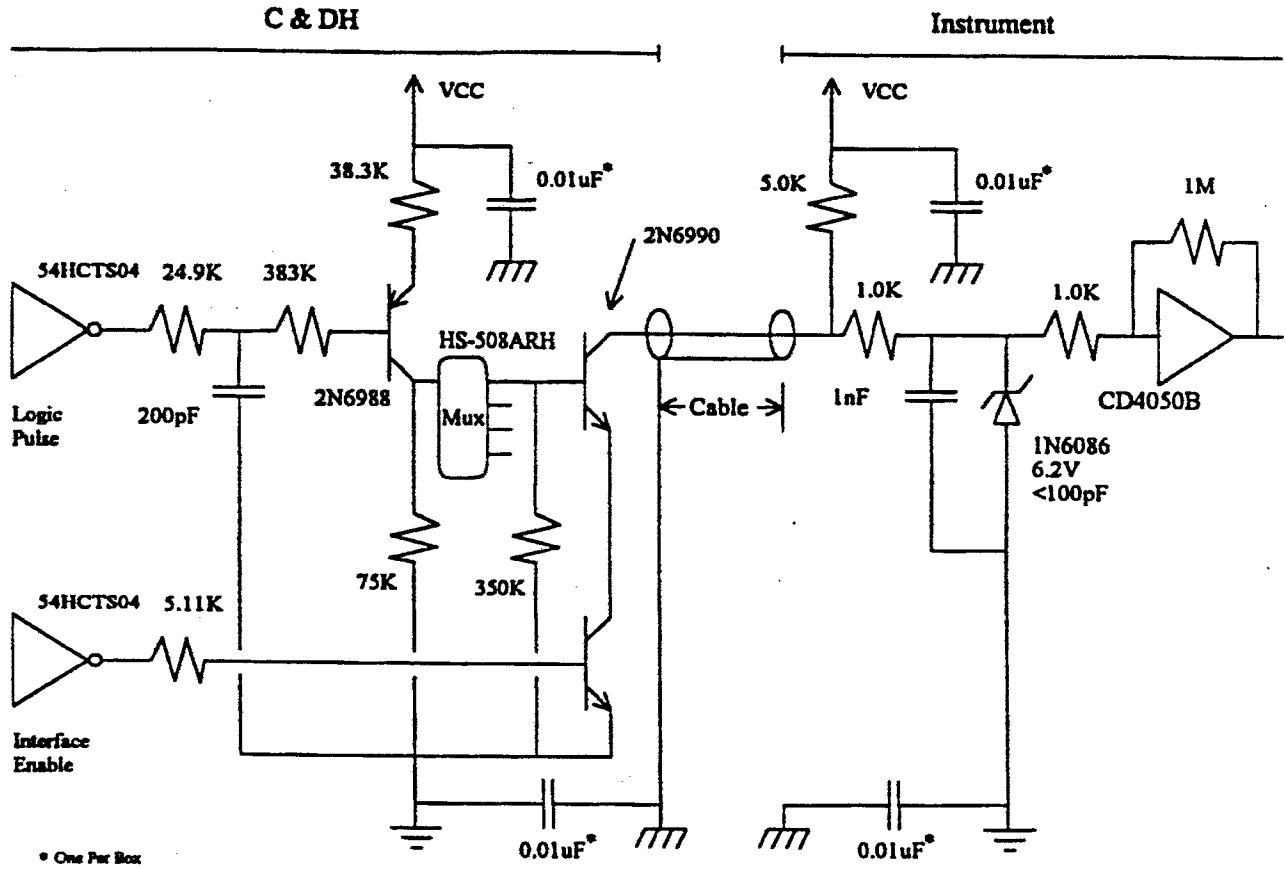

FSCM NO.	SIZE	DWG. NO.
88898	A	7345-9016
SCALE	DO NOT SCALE PRINT	SHEET
		2-32

Figure 2.5.4.1.2-2 SWIMS Logic Pulse Interface

THE SWIMS INSTRUMENT REQUIRES NO LOGIC PULSE INTERFACE WITH THE S/C

FSCM NO. 88898	SIZE A	DWG. NO. 7345-9016
SCALE	DO NOT SCALE PRINT	SHEET 2-33

The data are conveyed across a three signal interface (Enable, Clock and Data). The timing diagram of Figure 2.5.4.2-1 depicts the signals' relationships. The gated clock has a 50% duty cycle when present; the gated clock is only present when the data are actually being sent. The enable is an active low signal that will transition at least one quarter of a bit time before the clock transitions from high to low. Data is valid on the falling edge of the clock and will change on the rising edge. The enable will be removed with the rising edge of the clock on the last data bit transferred.

Memory load will be accomplished over the data interface using a maximum of 4096 bits in increments of 8 bits. Memory loads using a data command are treated identically by the C&DH component as any other type of data command.

2.5.4.2.1 Interface

The first level circuit diagram of Figure 2.5.4.2.1-1 is the suggested data interface. An advantage to this circuit is the high level reference is user supplied. Both interfaces depict a single C&DH component data command interface with the instrument. The instrument must make provision to accept these interfaces. Input buffers to one C&DH component should not share the same package with buffers to the second C&DH component. An instrument should not wired "or-ed" together the buffered data, clock and enable lines from one C&DH component with the equivalent signals from the other C&DH components. **Specific instrument data command interface is shown in Figure 2.5.4.2.1-2.**

2.5.4.3 Relay Command (Switched Power)

2.5.4.3.1 Description

Relay Commands control switched power for the spacecraft. The relays used for switching the power are grouped into two categories, Ordnance and Power Switching. The Ordnance Fire Component is responsible for switching power to the Ordnance on board the spacecraft. The Power Switching Component supplies switched power to the users on the spacecraft.

Latching relays are not redundant for these interfaces. In general, there are multiple contacts in each relay. Each relay contains two coils. One of the coils is controlled by C&DH component A and the other coil is controlled by C&DH component B. For relays switching power, the harness will contain one more wire than is required to carry the power to the user. Latching relays will utilize one contact as a position indicator. The state of the indicator is telemetered to the ground.

FSCM NO. 88898	SIZE A	DWG. NO. 7345-9016
SCALE	DO NOT SCALE PRINT	SHEET 2-34

Figure 2.5.4.2-1 Data Command Timing

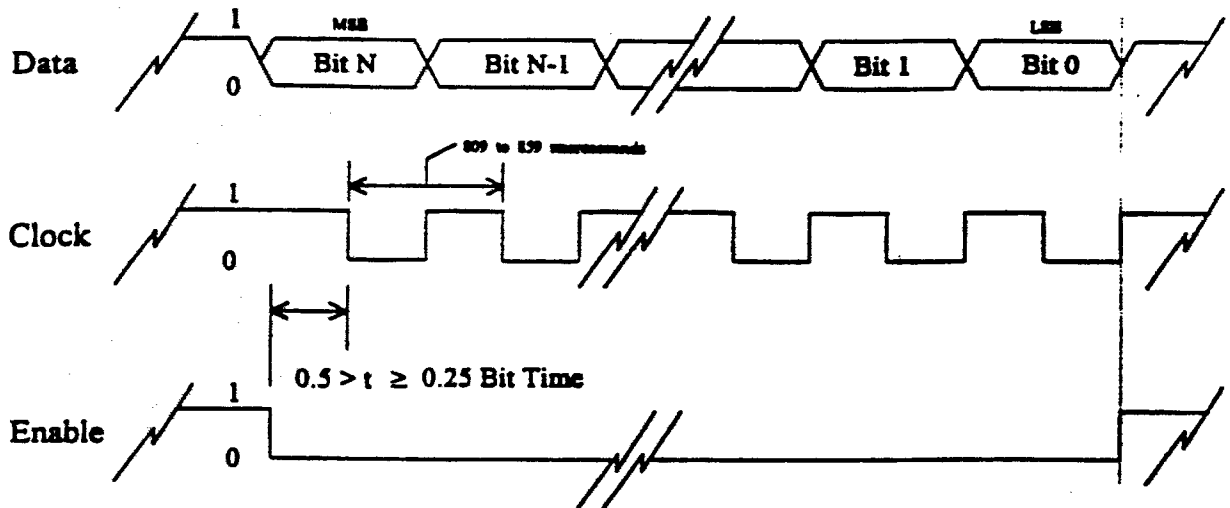

FSCM NO. 88898	SIZE A	DWG. NO. 7345-9016
SCALE	DO NOT SCALE PRINT	SHEET 2-35

Figure 2.5.4.2.1-1 Data Command Interface

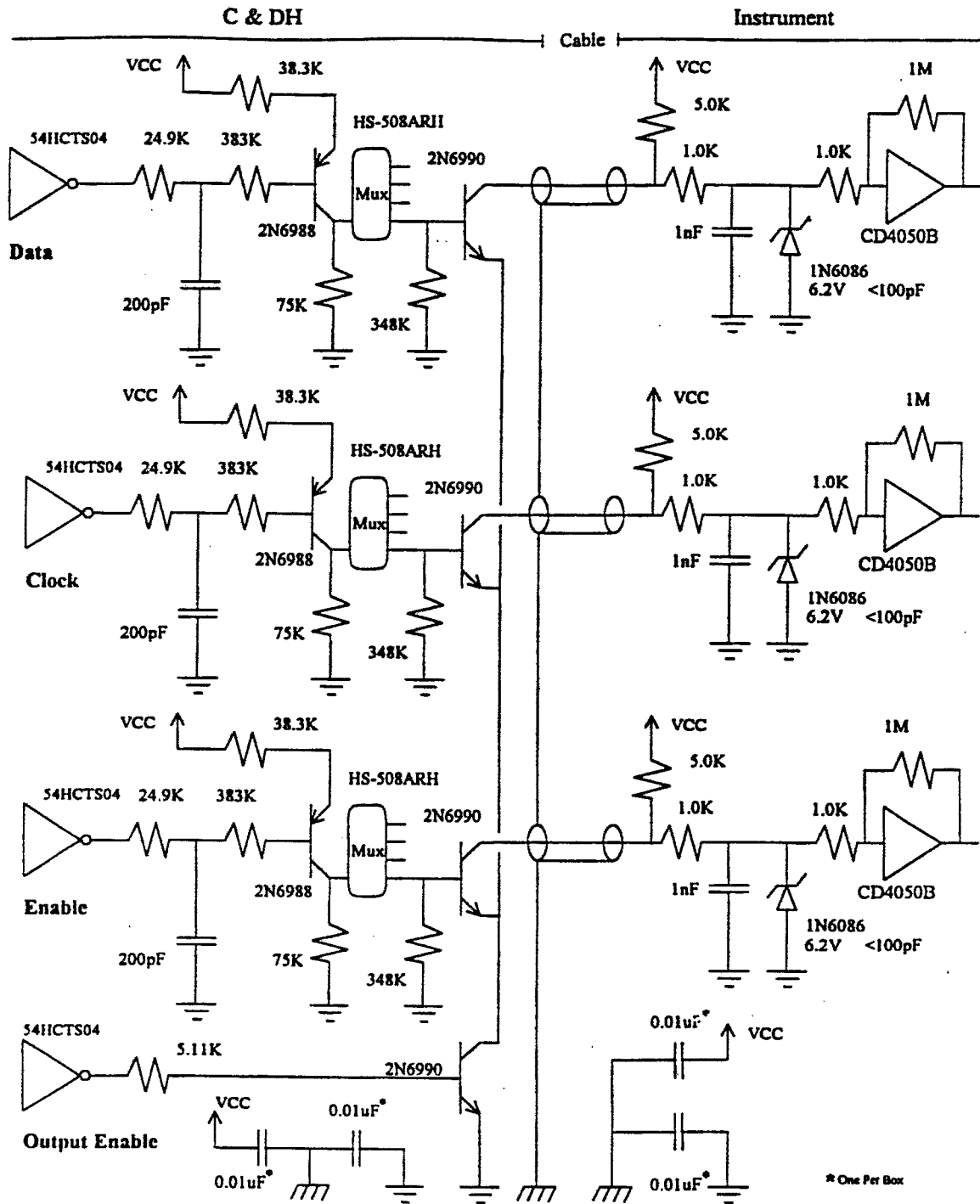

FSCM NO.	SIZE	DWG. NO.
88898	A	7345-9016
SCALE	DO NOT SCALE PRINT	SHEET
		2-36

Figure 2.5.4.2.1-2 SWIMS Data Command Interface

THE SWIMS INSTRUMENT REQUIRES NO DATA COMMAND INTERFACE WITH THE S/C.

FSCM NO. 88898	SIZE A	DWG. NO. 7345-9016
SCALE	DO NOT SCALE PRINT	SHEET 2-37

2.5.4.3.2 Interface

The following illustrates the typical power switching relay interface (see Figure 2.3-1). Relays are redundant at the coil level. The wires to the user will contain one more than necessary to carry the current. The current in the return line is sensed with a current sensing resistor on a spacecraft terminal board. **The instrument power relay interface is shown in Figure 2.5.4.3.2-1.**

2.5.4.4 Relay Command (Ordnance)

2.5.4.4.1 Interface

The following illustrates a typical Ordnance Fire Interface (Figure 2.5.4.4.1-1). Notice the enable relay in series with the actual fire relay. The Ordnance Fire Component also provides 100 ohm resistors to ground in the safe position of the fire relay. The resistors in series with each ordnance is to current limit the ordnance line. Instruments shall specify minimum all fire current, recommended all fire current, maximum all fire current, maximum fire current, and maximum no fire current.

The diagram in Figure 2.5.4.4.1-1 illustrates the wiring for the Ordnance used by a user with two redundant pyros. The Ordnance Fire Component uses one enable relay for multiple pyro, in this case two "A" and "B." Each pyro has a primary and backup side. Both primary and back-up pyros may be fired simultaneously, if specified in Figure 2.5.4.4.1-2. Not shown are the relay coils that are driven from each C&DH component. The exact ordnance relay configuration for each instrument is documented in the instrument SIIS. The requirements of Eastern Range Requirement Document (127-1) will apply except as noted in the SIIS. Pyrotechnic circuits shall be isolated from all other instrument circuits. A separate pyro connector shall be used. **The instrument ordnance fire interface is shown in Figure 2.5.4.4.1-2.**

2.5.4.4.1.1 Pyrotechnic Firing Voltage

Pyrotechnic firing voltage will be between 19 and 27 VDC; no fuses will be used in the pyrotechnic firing circuit. The pyrotechnic firing bus will be redundant.

2.5.4.4.1.2 Firing Circuitry

Firing of pyrotechnics is the responsibility of the ACE spacecraft. Each firing circuit shall be separately switched and consist of a shielded, twisted drive/return line pair. Firing of pyrotechnics shall require separate enable sequence and fire commands.

2.5.4.4.1.3 Pyrotechnic Safety Short and Arm Plugs

Each pyrotechnic device, when practical, shall have a shorting device at the ordnance element which is accessible without disassembly of the instrument/sensor at the Observatory level. The spacecraft will have pyrotechnic arming plugs that will be installed prior to launch. **See Figure 2.5.4.4.1-2**

FSCM NO. 88898	SIZE A	DWG. NO. 7345-9016
SCALE	DO NOT SCALE PRINT	SHEET 2-38

Figure 2.5.4.3.2-1 SWIMS Power relay Interfaces

Switched Power Interface/s.

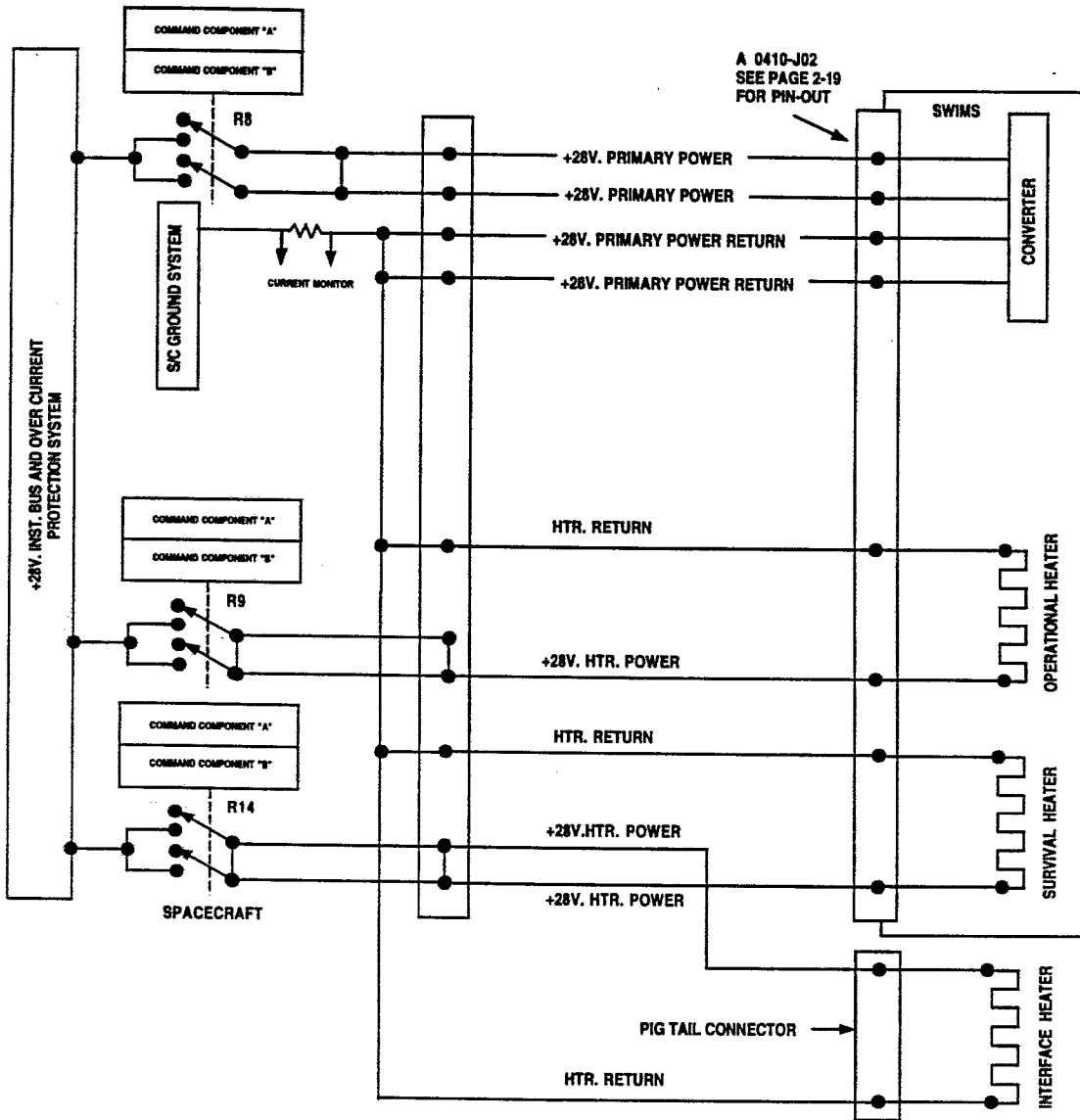

FSCM NO.	SIZE	DWG. NO.
88898	A	7345-9016
SCALE	DO NOT SCALE PRINT	SHEET 2-39

Figure 2.5.4.4.1-1 Typical Ordnance Fire Control

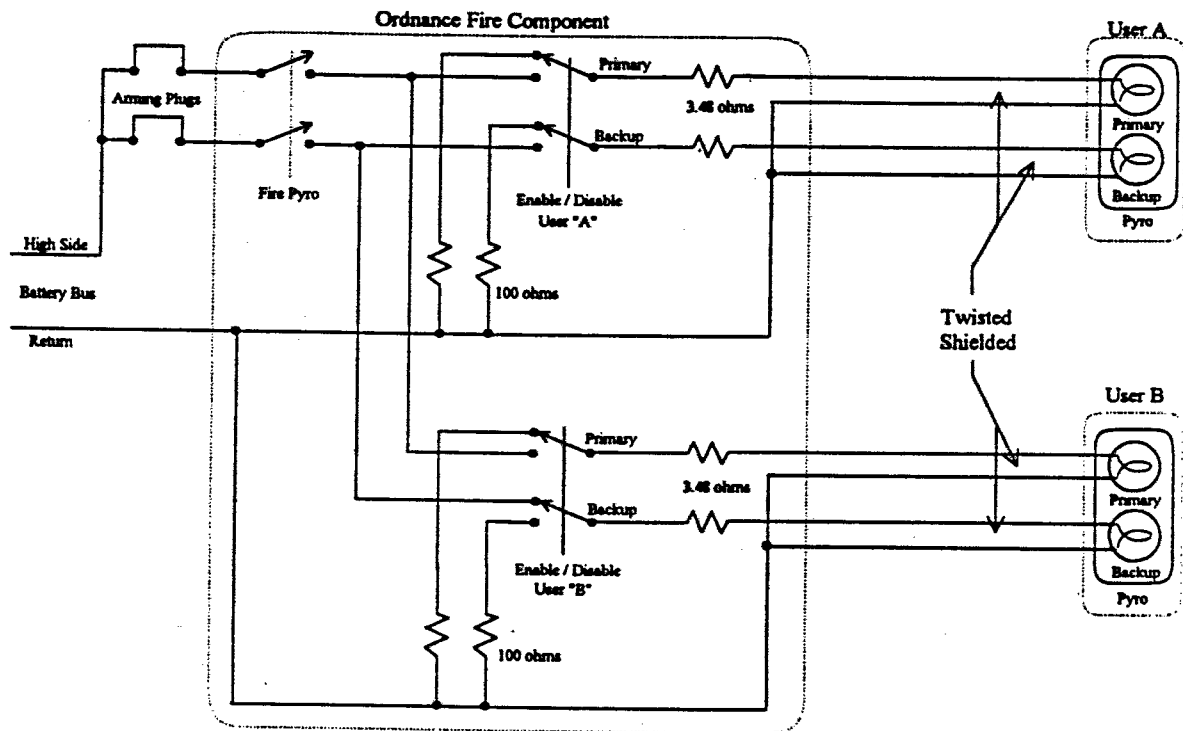

FSCM NO.	SIZE	DWG. NO.
88898	A	7345-9016
SCALE	DO NOT SCALE PRINT	SHEET
		2-40

Figure 2.5.4.1-2 SWIMS Ordnance Fire Interface

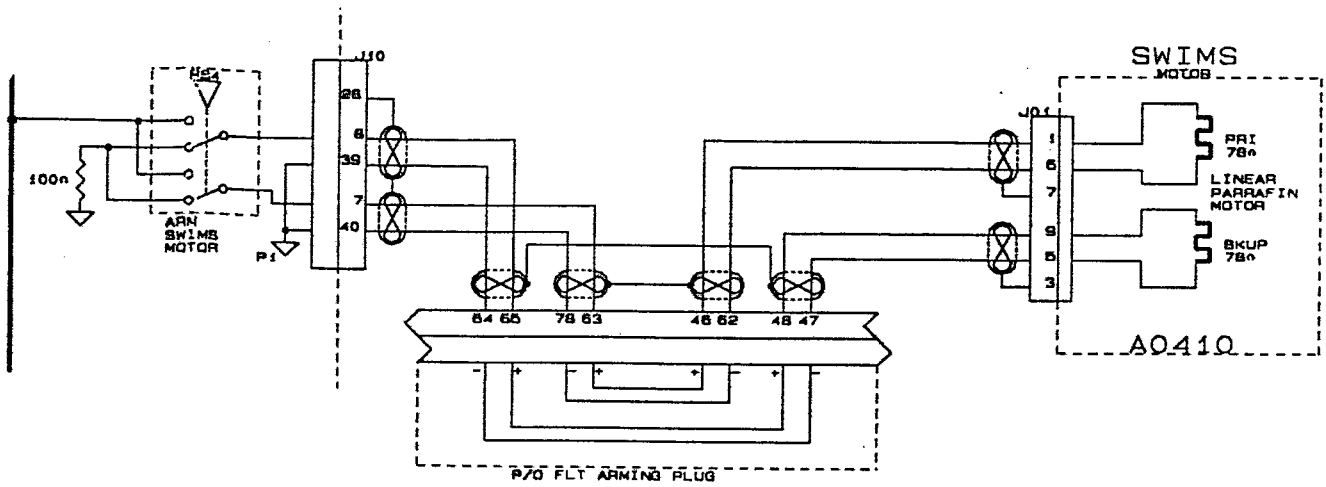

STARSYS RESEARCH TYPE
 HIGH OUTPUT PARAFFIN
 (HOP) MOTOR
 P/N IH2055-TC-A
 MIN FIRE @22V
 MAX FIRE @ 34V
 78° HEATER TIME
 REQUIREMENT 1.5 TO 4MIN

FSCM NO. 88898	SIZE A	DWG. NO. 7345-9016
SCALE	DO NOT SCALE PRINT	SHEET 2-41

2.5.4.4.1.4 Pyrotechnic Circuit Shields

The pyrotechnic firing circuit within each instrument/sensor shall be continuously shielded from the ordnance device to the interface connector. The shields shall not be used as intentional current-carrying conductors. The shields shall be grounded to the structure at multiple points.

2.5.4.5 Remote Relay Command

Remote Relay commands provide a pulsed +28 V signal or a pulsed ground signal used for switching relays in instrument packages. The pulse can have a selectable duration of 20, 40, 60, or 80 milliseconds. The remote relay command is implemented with non-latching relays in the spacecraft power switching component. **The exact interface and configuration of the remote relay command, if required, is documented in Figure 2.5.4.5-1.**

2.6 SPACECRAFT C&DH SUBSYSTEM - DATA HANDLING PORTION

Each C&DH Component includes data handling functions. Each C&DH Component collects digital science and housekeeping data, collects and digitizes analog data, and forms a composite serial data stream made up of minor and major frames. A major frame is 16 seconds long and consists of 16 minor frames. Each minor frame makes up the data field of a CCSDS compatible packet, and each packet makes up the data field of a Virtual Channel Data Unit (VCDU), which is the format to be compatible with NASA's ground data system.

Each C&DH Component can connect to instruments with several types of standard telemetry interfaces. These interfaces are serial digital (for science, housekeeping, and memory dump); digital telltale; 0 to +5 V Analog single ended; 0-50 mV differential; and temperature sensor. The instruments need to replicate each telemetry interface that it uses to each C&DH Component.

2.6.1 Data Handling Component Interfaces

The number of each interface type that can be provided to each instrument is limited, and must be negotiated.

2.6.1.1 Serial Digital - Science, Housekeeping, and Memory Dump

2.6.1.1.1 Description

A serial digital interface is used to collect a fixed amount of serial digital data at a periodic interval from each instrument. Data collection will occur in exactly the same spot and will be the same length in any minor frame. Each C&DH component can limit check telemetry data, and execute a command if an out-of-limit condition is detected. The instrument data can be limit checked by a C&DH Component only if the data is in a fixed location in the spacecraft minor frame. Each instrument has been allocated a single serial digital interface per C&DH component.

FSCM NO. 88898	SIZE A	DWG. NO. 7345-9016
SCALE	DO NOT SCALE PRINT	SHEET 2-42

Figure 2.5.4.5-1 SWIMS Remote Relay Command Interface

NOT APPLICABLE

FSCM NO. 88898	SIZE A	DWG. NO. 7345-9016
SCALE	DO NOT SCALE PRINT	SHEET 2-43

Instruments will not be provided with a separate interface for memory dumps. If an instrument needs to dump memory contents, it should replace its normal allocation of science data with dump data. Typically, a command to the instrument would place it in the dump mode for a fixed number of major frames. Science and dump data should be formatted so that the ground decommutation process can detect which type of data is present. Typically, data is output most significant bit first.

Figure 2.6.1.1.1-1 shows the bit allocation for each payload instrument/sensor, and the SSS DPU.

2.6.1.1.2 Interface

Each C&DH Component provides each instrument with the following signals:

- a) Minor Frame Pulse - an active high pulse at the start of every minor frame
- b) Major Frame Pulse - an active high pulse at the start of every major frame, also called 1xMajor Frame Pulse
- c) Clock - a continuous clock at 10,956 Hertz. Exactly 10,956 clock pulses will be generated between minor frame pulses.
- d) Read Out Gate (ROG) - an active high envelope indicating when instruments should output serial data in response to the Clock

In addition, each C&DH Component will provide the following signals only to those instruments that need them:

- a) 2xMajor Frame Pulse - an active high pulse at the start of every other major frame.
- b) 4xMajor Frame Pulse - an active high pulse at the start of every fourth major frame.
- c) 8xMajor Frame Pulse - an active high pulse at the start of every eighth major frame.

In response to these signals, the instrument will output serial data over the Data line with the falling edge of the Clock signal. The first circuit interface is shown in Figure 2.6.1.1.2-1. **The instrument specific interface is shown in figure 2.6.1.1.2-2.** This interface must be duplicated to each C&DH Component. (The instrument must generate a DH select bit in order to select one of the interfaces. Typically an instrument would use a data command to generate the select bit to select the active side.) **Instruments shall provide information on the method used to select the active data interface. This data shall be provided in Figure 2.6.1.1.2-3.** The components used to implement the interface to each C&DH shall be physically distinct and separate; no single component shall serve both redundant interfaces. Interface timing is shown in Figure 2.6.1.1.2-4.

FSCM NO. 88898	SIZE A	DWG. NO. 7345-9016
SCALE	DO NOT SCALE PRINT	SHEET 2-44

Figure 2.6.1.1.1-1 Downlink Bit Allocation for Each Payload Instrument/Sensor

Payload Serial Digital Channel Allocations Per Minor Frame

Instrument	Science Format bits (1)	RTSW Format	Total bits Read out by C&DH
CRIS	464		464
SIS	1992		1992
ULEIS	1000		1000
EPAM	168	168	168
MAG	304	48	304
SWEPAM Ion	544	168	712
SWEPAM Electron	456		456
S ³ DPU	1624		1624
TOTAL	6552	384	6552

(1) Instrument bit stream includes instrument housekeeping and science data.

FSCM NO. 88898	SIZE A	DWG. NO. 7345-9016
SCALE	DO NOT SCALE PRINT	SHEET 2-45

Figure 2.6.1.1.2-1 Serial Digital Interface

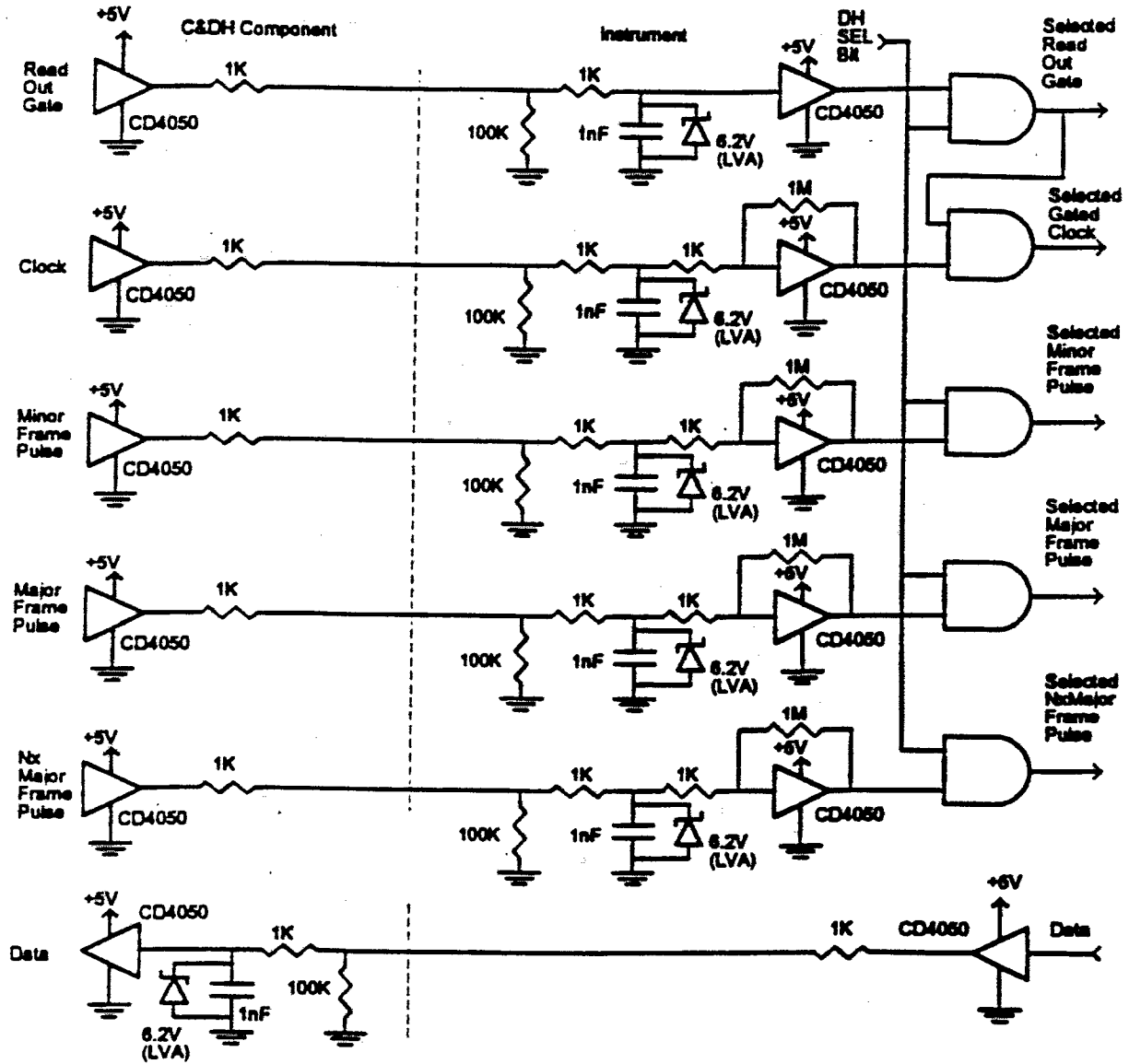

FSCM NO. 88898	SIZE A	DWG. NO. 7345-9016
SCALE	DO NOT SCALE PRINT	SHEET 2-46

**Figure 2.6.1.1.2-2 SWIMS Science, Housekeeping, and Memory Dump Digital Interface
(Serial Digital Interface)**

N/A. SERVICE THROUGH THE S3DPU.

FSCM NO. 88898	SIZE A	DWG. NO. 7345-9016
SCALE	DO NOT SCALE PRINT	SHEET 2-47

Figure 2.6.1.1.2-3 SWIMS Method Used to Select Active Data Channel

N/A. SERVICE THROUGH THE S3DPU.

FSCM NO. 88898	SIZE A	DWG. NO. 7345-9016
SCALE	DO NOT SCALE PRINT	SHEET 2-48

Figure 2.6.1.1.2-4 Serial Digital Interface Timing

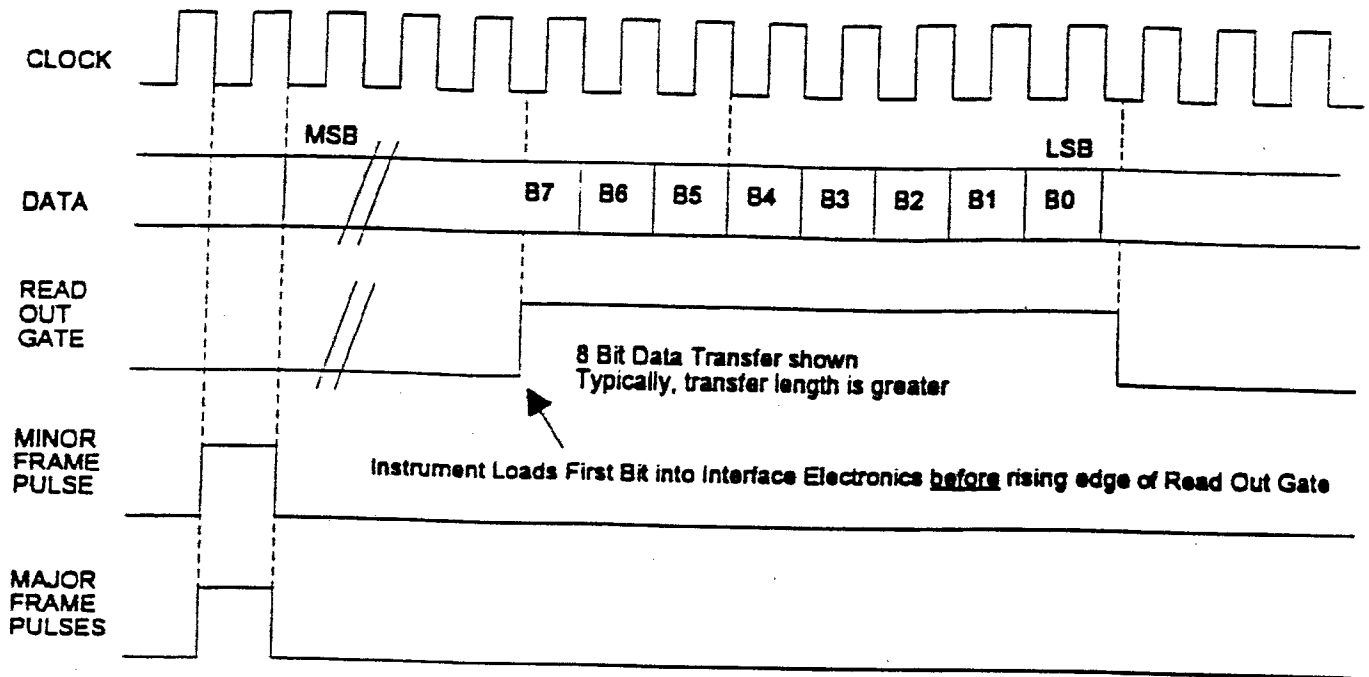

Notes:

1. Instrument initiates load of first bit before the rising edge of Read Out Gate (after Minor Frame Pulse).
2. After first data bit, instrument loads next data bit on falling edge of clock, C&DH Component reads on rising edge of clock. The data must be stable 1/4 bit time before the rising edge of the clock signal.
3. Major Frame pulses (1x, 2x, and 8x) not present every minor frame.
4. Low = logic 0 = Ground; High = logic 1 = 5V.
5. Minor and Major Frame Pulses may be delayed from the clock edges by up to 5 microseconds.

FSCM NO. 88898	SIZE A	DWG. NO. 7345-9016
SCALE	DO NOT SCALE PRINT	SHEET 2-49

2.6.1.2 Digital Telltales

2.6.1.2.1 Description

The digital telltale interface will be used to sample the state of a two state device (such as a switch) in an instrument. It is only appropriate to use a digital telltale interface if the state of the device must be sampled when the instrument is turned off (otherwise the instrument could embed the telltale in its serial telemetry stream).

2.6.1.2.2 Interface

Two types of digital telltale interfaces are available. If +5V is available in the device to be sampled, the telltale can be buffered with a CD4050 device. If the telltale is derived from a switch, and +5V is not available to establish two levels, the switch should connect to signal ground in one state and be open in the other state. The two interfaces are shown in Figure 2.6.1.2.2.-1. **The instrument specific interface is shown in Figure 2.6.1.2.2-2.**

2.6.1.3 0-5V Single Ended Analog Interface

2.6.1.3.1 Description

The interface is used to sample and digitize voltages which have been conditioned to be within a 0 to 5V range. Note that if the output of a +5V DC-DC converter is to be sampled, the telemetry point should be a resistively divided version of the converter output so that a converter output over-voltage can be sensed. Subcommutated interfaces will be supported but must be synchronized to the 2x or the 8x major frame pulse. Note: users should not assume that the least significant bit is free from noise.

2.6.1.3.2 Interface

The first circuit interface is shown in Figure 2.6.1.3.2-1. Note: The op amp used to buffer the single-ended voltage should be capable of maintaining its output voltage if the output to one C&DH component is grounded. Power supply voltages can use two resistive dividers instead of an op amp. **The instrument specific interface is shown in Figure 2.6.1.3.2-2.**

2.6.1.4 0 to +50mV Differential Analog Interface

2.6.1.4.1 Description

The interface is typically used to sample the voltage across a current sensing resistor.

FSCM NO. 88898	SIZE A	DWG. NO. 7345-9016
SCALE	DO NOT SCALE PRINT	SHEET 2-50

Figure 2.6.1.2.2-1 Digital Telltale Interface

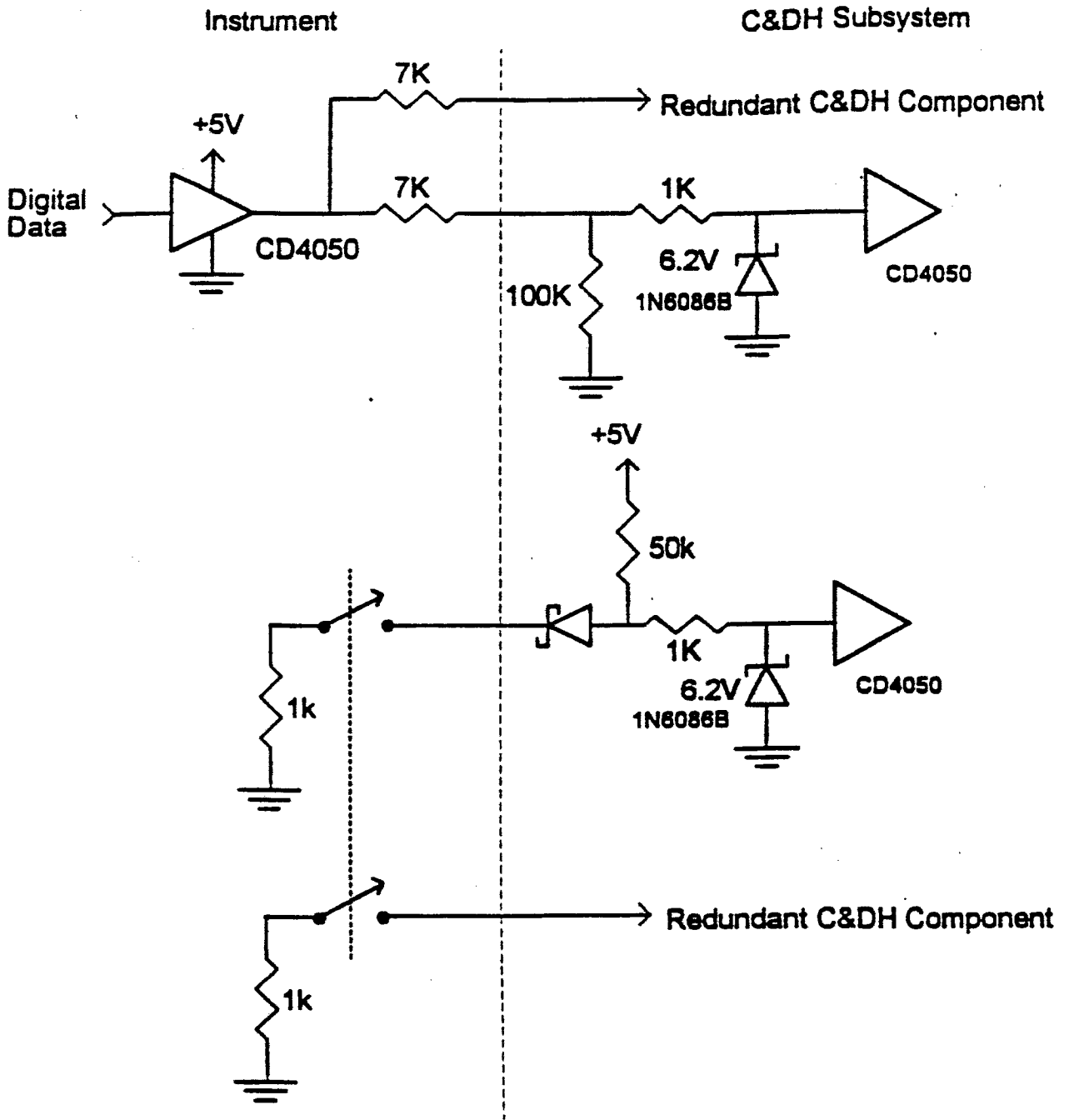

FSCM NO. 88898	SIZE A	DWG. NO. 7345-9016
SCALE	DO NOT SCALE PRINT	SHEET 2-51

Figure 2.6.1.2.2-2 SWIMS Digital Telltale Interface

The SWIMS Instrument requires 1 redundant digital telltail interface to indicate the position of the aperture door. The interface circuit is shown below.

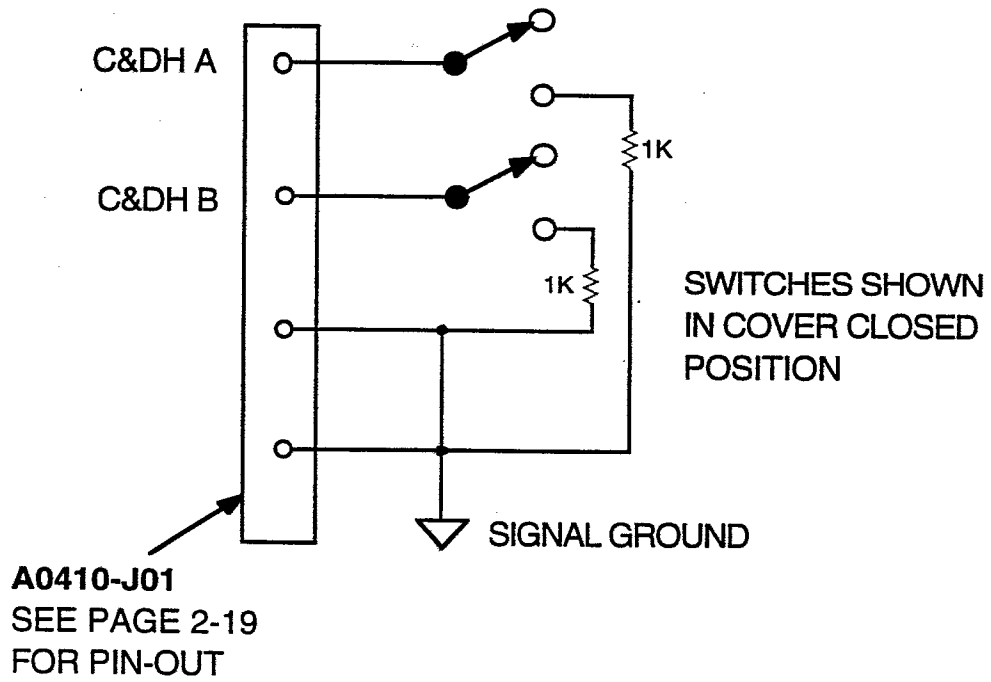

FSCM NO. 88898	SIZE A	DWG. NO. 7345-9016
SCALE	DO NOT SCALE PRINT	SHEET 2-52

Figure 2.6.1.3.2-1 Single Ended Analog 0-5V Interface

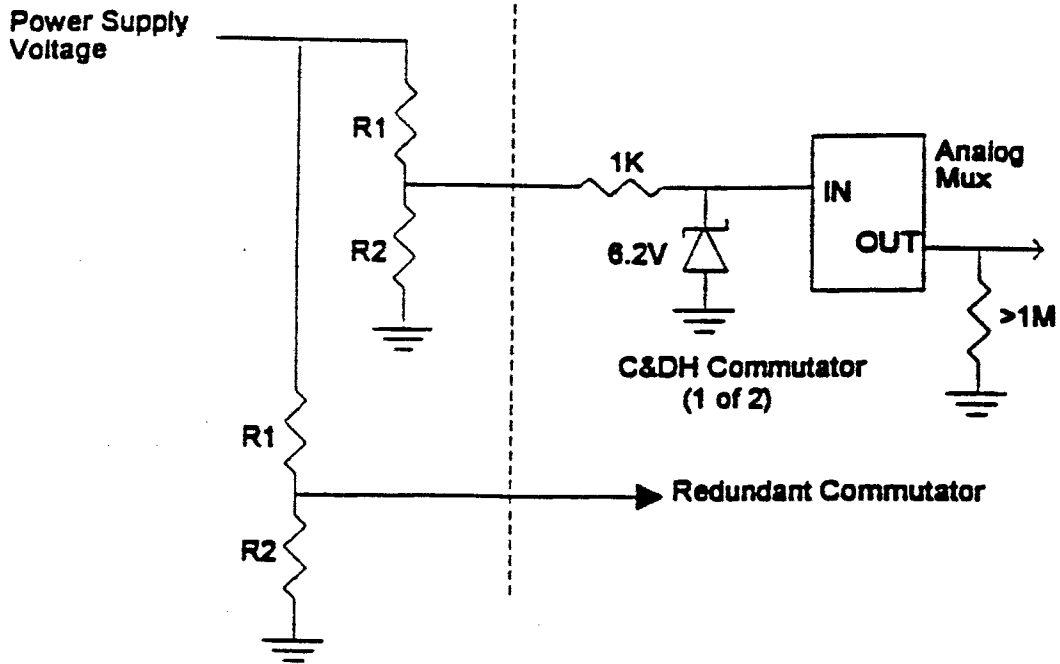
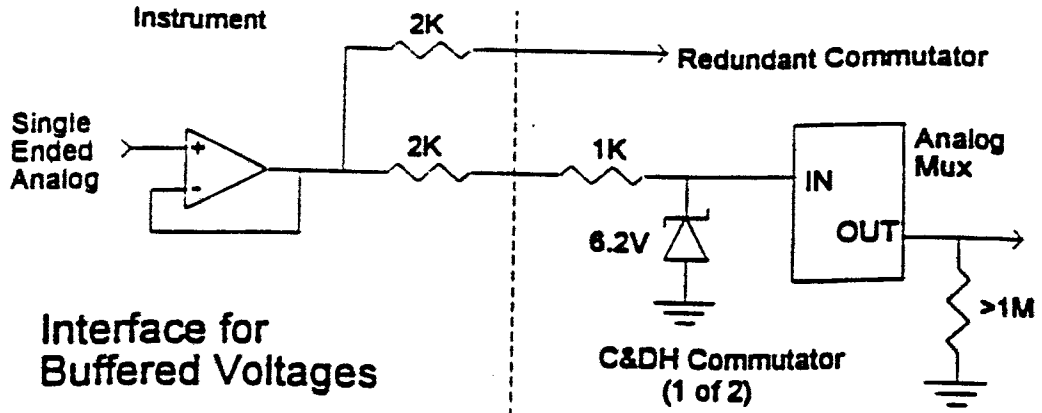

FSCM NO.	SIZE	DWG. NO.
88898	A	7345-9016
SCALE	DO NOT SCALE PRINT	SHEET
		2-53

Figure 2.6.1.3.2-2 SWIMS Single Ended Analog 0-5V Interface

N/A. SERVICE THROUGH THE S3DPU.

FSCM NO. 88898	SIZE A	DWG. NO. 7345-9016
SCALE	DO NOT SCALE PRINT	SHEET 2-54

2.6.1.4.2 Interface

The first circuit interface is shown in Figure 2.6.1.4.2-1. **The instrument specific interface is shown in Figure 2.6.1.4.2-2.**

2.6.1.5 Temperature Sensor Interfaces

2.6.1.5.1 Description

Two temperature sensors are available for new instrument/sensor designs. The AD590 is for use over the range of -60 to +100° C. It is packaged in a 2 lead flatpack. The PT-103 is for use over the range of -100 to +150 ° C. It is a platinum wire sensor. Existing instrument/sensor designs using spacecraft powered will be treated in detail in their respective SIIS.

2.6.1.5.2 Interface

The first circuit interfaces are shown in Figure 2.6.1.5.2-1. Note that a separate temperature sensor is required to interface to each C&DH Component. **The instrument specific interface is shown in Figure 2.6.1.5.2-2.**

2.6.1.6 Sun Pulse and Spin Clock

2.6.1.6.1 Description

Each C&DH component is connected to a two axis Sun Sensor. Each Sun Sensor outputs an 8 bit X Sun Angle and an 8 bit Y Sun Angle. The C&DH Component generates a Sun Pulse based on the rising edge of the msb of the X-Axis Sun Sensor Angle. The Sun Pulse will be 732+/-TBD μ s long. The C&DH Component will distribute the Sun Pulse to those instruments that require them. Each C&DH Component will also generate and distribute a Spin Clock. The Spin Clock will contain 16384+/-10 (TBR) pulses between each rising edge of the Sun Pulse. The +/-10 (TBR) error includes all normal perturbations of the Sun Pulse, and not just error in the generation of the Spin Clock. A timing diagram of the Sun Pulse and Spin Clock is shown in Figure 2.6.1.6.1-1.

The instrument should use the same Data Handling Select Bit used to select the active Serial Digital Telemetry interface to select the active Sun Pulse and Spin Clock interface. Typically, an instrument would use a Data Command to generate the select bit and select the active side. **Note: users need to "remember" which side of the C&DH interface to use after resets.**

2.6.1.6.2 Interface

Each C&DH Component will provide each instrument with a Sun Pulse interface and a Spin Clock interface. The first circuit interface is shown in Figure 2.6.1.6.2-1. The components used to implement the interface to each C&DH Component shall be physically distinct and separate; no single component shall serve both redundant interfaces. **The instrument specific sun pulse interface is shown in Figure 2.6.1.6.2-2.**

FSCM NO.	SIZE	DWG. NO.	7345-9016
88898	A		
SCALE	DO NOT SCALE PRINT		SHEET 2-55

Figure 2.6.1.4.2-1 Differential Analog Interface

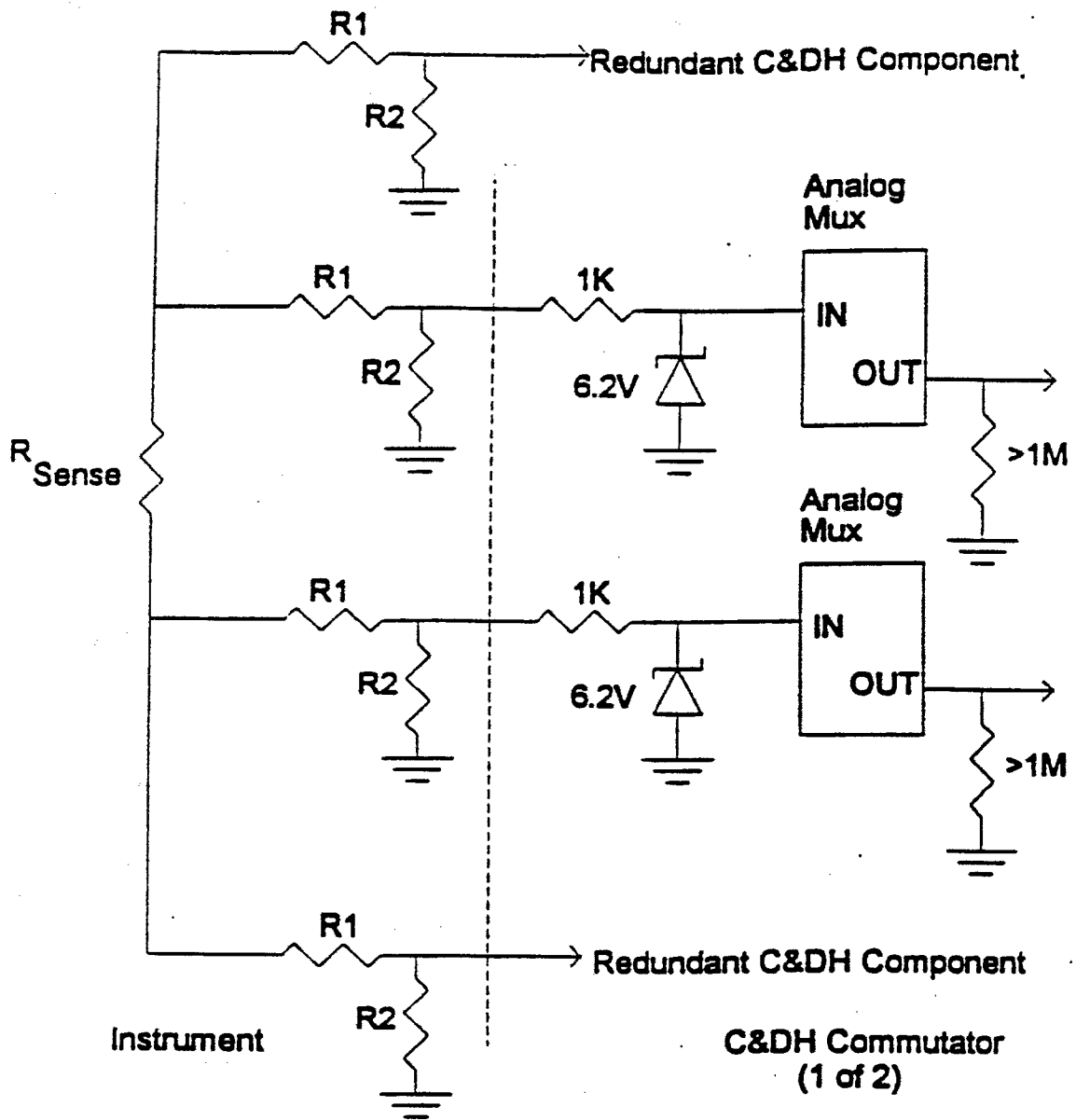

FSCM NO.	SIZE	DWG. NO.
88898	A	7345-9016
SCALE	DO NOT SCALE PRINT	SHEET 2-56

Figure 2.6.1.4.2-2 SWIMS Differential Analog Interface

NOT APPLICABLE.

FSCM NO. 88898	SIZE A	DWG. NO. 7345-9016
SCALE	DO NOT SCALE PRINT	SHEET 2-57

Figure 2.6.1.5.2-1 Temperature Sensor Interfaces

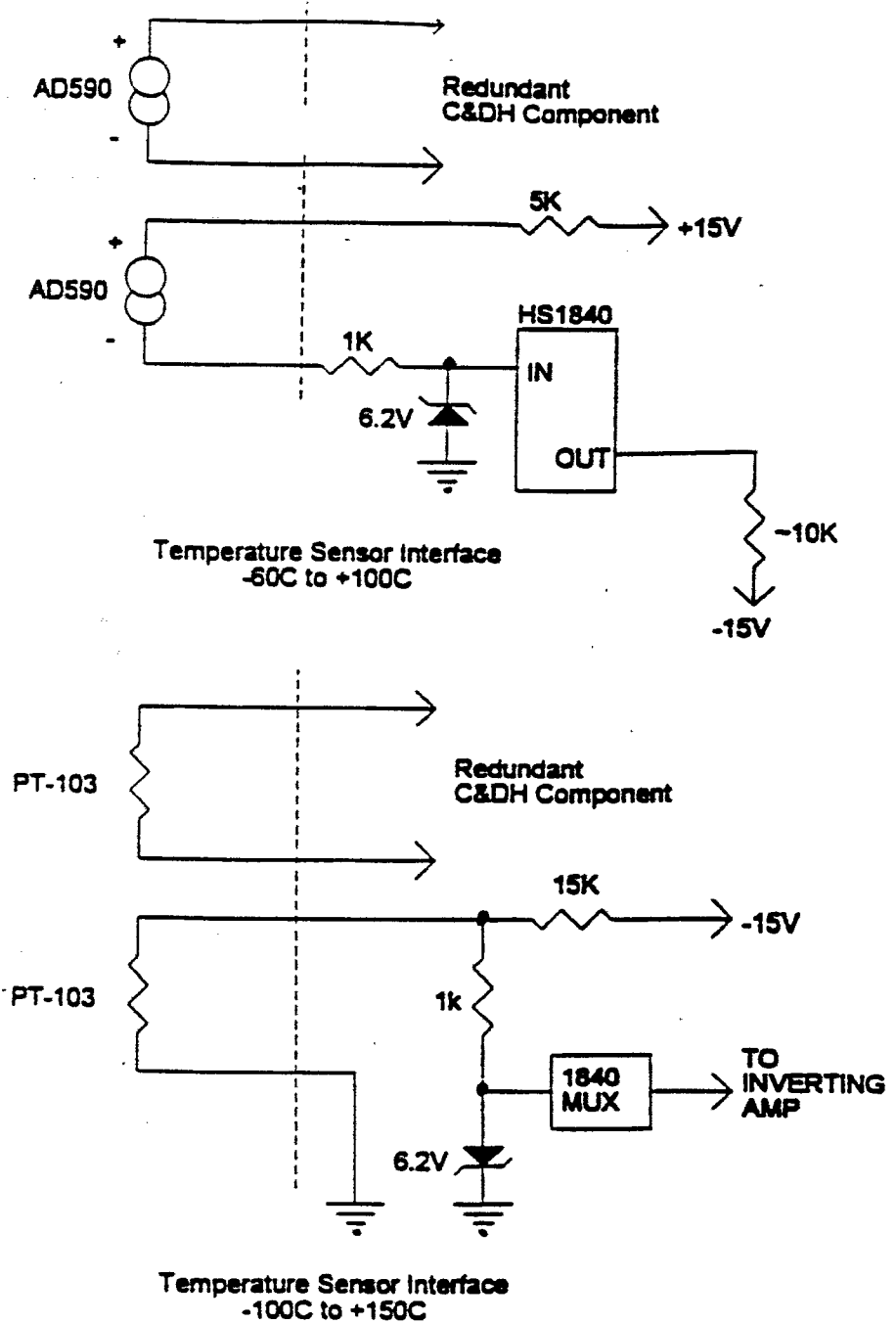

FSCM NO. 88898	SIZE A	DWG. NO. 7345-9016
SCALE	DO NOT SCALE PRINT	SHEET 2-58

Figure 2.6.1.5.2-2 SWIMS Temperature Sensor Interfaces

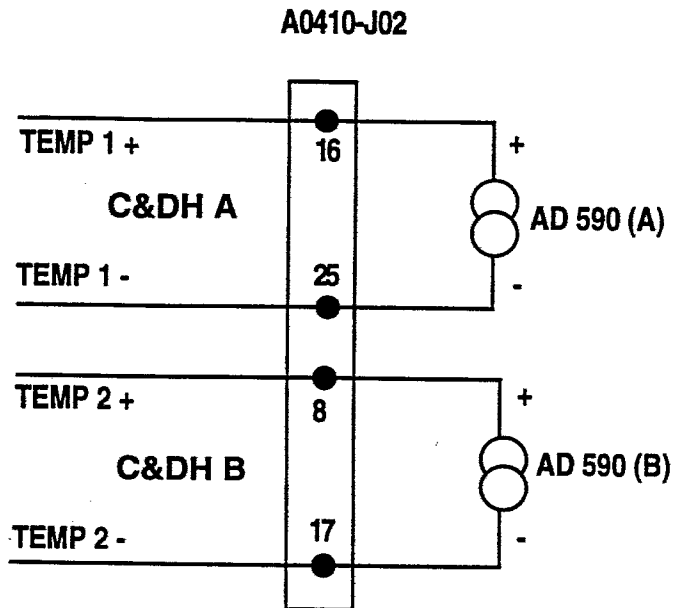

FSCM NO. 88898	SIZE A	DWG. NO. 7345-9016
SCALE	DO NOT SCALE PRINT	SHEET 2-59

Figure 2.6.1.6.1-1 Sun Pulse/Spin Clock Interface Timing

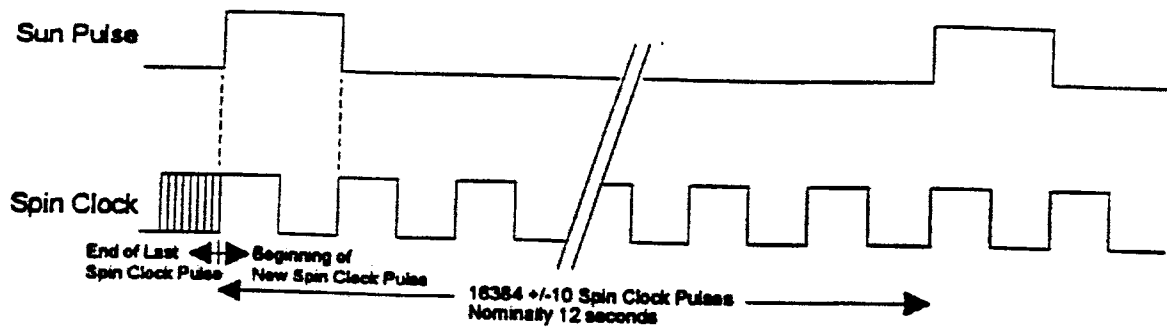

FSCM NO. 88898	SIZE A	DWG. NO. 7345-9016
SCALE	DO NOT SCALE PRINT	SHEET 2-60

Figure 2.6.1.6.2-1 Sun Pulse/Spin Clock Interface

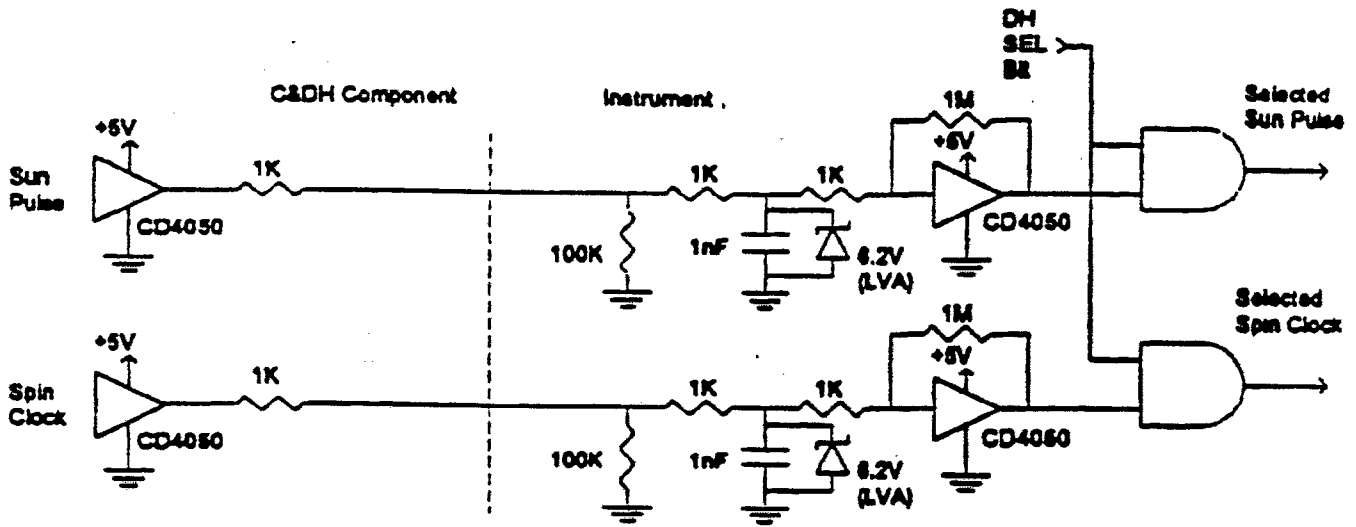

FSCM NO. 88898	SIZE A	DWG. NO. 7345-9016
SCALE	DO NOT SCALE PRINT	SHEET 2-61

Figure 2.6.1.6.2-2 SWIMS Sun Pulse/Spin Clock Interface

N/A.; SERVICE THROUGH THE S3DPU.

FSCM NO. 88898	SIZE A	DWG. NO. 7345-9016
SCALE	DO NOT SCALE PRINT	SHEET 2-62

2.6.1.6.3 Sun Sensor Failure

If the Sun Sensor connected to the active Data Handling Component fails, the C&DH Component will no longer transmit a valid Sun Pulse and/or Spin Clock. The lack of a valid Sun Pulse will not be detected in a C&DH Component; a simulated Sun Pulse will not be generated and distributed. Sun Sensor failure would not be detected until the next ground pass (up to approximately 48 hours). At that time, the primary C&DH Component and Sun Sensor would be turned off, and the backup C&DH Component and Sun Sensor would be turned on.

2.7 PAYLOAD INSTRUMENT/SENSOR SYNCHRONIZATION SIGNALS

2.7.1 General

The spacecraft will supply sync. signals to the instruments/sensors which are related to the basic digital data rates, or are related to spacecraft generated attitude data. The characteristics of these sync. signals and the first circuit interfaces shall be documented in the SIIS's.

2.7.1.1 Available Synchronization Signals

The following synchronization signals are available from the spacecraft:

- a) Major Frame Pulse (an active high pulse at the start of every major frame)
- b) 2xMajor Frame Pulse (an active high pulse at the start of every 2 major frames)
- c) 8xMajor Frame Pulse (an active high pulse at the start of every 8 major frames).
- d) Minor Frame Pulse (an active high pulse at the start of every minor frame)
- e) Sun Pulse
- f) Spin Clock

FSCM NO. 88898	SIZE A	DWG. NO. 7345-9016
SCALE	DO NOT SCALE PRINT	SHEET 2-63

3.0

MECHANICAL INTERFACE REQUIREMENTS

This section describes the mechanical interfaces between the payload instruments and the spacecraft. These interfaces include the envelopes, mounting mass, products of inertia, and other mechanical forces which may be transmitted from the payload instrument to the spacecraft. The mechanical environment to which the Observatory will be tested (sine and random vibration, acoustic and shock) and recommended levels for instrument/sensor level testing are given in the ACE Environmental Specification APL 7345-9007.

3.1 **INSTRUMENT PHYSICAL CHARACTERISTICS**

3.1.1 **Mass**

The payload instrument/sensor mass including grounding straps, bolts, brackets, etc., shall be established and recorded in the Specific Instrument Interface Specification. Flight hardware shall be weighed, and the mass of each instrument/sensor assembly shall be documented to an accuracy of 1% or 1 pound, whichever is less. If the orbital configuration differs from the launch configuration (i.e., deployable covers, etc.), the mass in each configuration shall be specified. **Note: Mass estimates are shown in Figure 3.1.3-1. Please consult Caltech Table 3.2-1, Science Payload Mass Estimates.**

3.1.2 **Size**

Payload instrument/sensor size and envelope shall be established by the experimenter and documented in each of the Specific Instrument Interface Documents, including volume required for deploying sensor protective covers.

3.1.3 **Center of Mass**

Payload instrument/sensor center of mass shall be established to an accuracy of $\pm 10\%$ and documented in **Figure 3.1.3-1 and/or on the mechanical ICD drawing. Any deviation in center of mass due to deployment of protective covers shall defined and documented in the Figure 3.1.3-2.**

3.1.4 **Moments of Inertia**

The accuracy of payload instrument/sensor moments of inertia calculations shall have a goal of $\pm 10\%$ and documented in each of the Specific Instrument Interface Documents.

3.1.5 **Mechanical Interface Drawings**

Each payload instrument/sensor experimenter shall supply the following applicable Interface Control Drawings, Procedures, and Tables for inclusion in the Specific Instrument Interface Documents. **Note: S/C shall provide general drawing of instrument locations in the SIIS. All dimensions and notes shall be in English units of measure.**

- a) Envelope drawing - (Cover Stowed, Transition, Open)
- b) Center of Mass Location/Moments of Inertia

FSCM NO. 88898	SIZE A	DWG. NO. 7345-9016
SCALE	DO NOT SCALE PRINT	SHEET 3-1

Figure 3.1.3-1 SWIMS Mass and Center of Mass

MASS (Incl. thermal items)	UNITS	CENTER of MASS			UNITS	MOMENTS of INERTIA			UNITS
		\bar{X}	\bar{Y}	\bar{Z}		I_x	I_y	I_z	
8250	grams	122.5,	12.9,	202.3	mm	.087	.105	.073	kg m ²
18.19	lb	4.823,	.508,	7.965	inch	.0642	.0775	.0538	lb ft sec ²
		(COVER CLOSED)							
		4.873,	.508	7.952 ©	inch				
		(COVER OPEN)							

FSCM NO. 88898	SIZE A	DWG. NO. 7345-9016
SCALE	DO NOT SCALE PRINT	SHEET 3-2

Figure 3.1.3-2 Instrument Center of Mass Change Due to Cover Actuation

NEGLIGIBLE

FSCM NO. 88898	SIZE A	DWG. NO. 7345-9016
SCALE	DO NOT SCALE PRINT	SHEET 3-3

- c) Field-of View Drawing
- d) Alignment reference marks
- e) Mass
- f) Adjustments
- g) Full Sized Mechanical Interface Drawing
- h) Mounting Interface Preparation
- i) Mounting Hardware and Torque Specifications
- j) Connector Locations
- k) Connector Identification
- l) Red and Green Tag Items
- m) Test Connectors and Locations
- n) Special Grounding Provisions
- o) Access Requirements
- p) Handling Fixtures Interfaces and Lift Point Locations
- q) Heat Pipe Locations
- r) Location of Purge Connector
- s) Location of Pyro Actuators
- t) Critical Harness Routing/Requirements (u) Thermal/Optical Properties of Instrument Exterior Surfaces.

Specific instrument mechanical interface drawings are located in Appendix A.

3.2 INSTRUMENT MOUNTING

3.2.1 General

Payload instruments/sensors shall be designed for installation and removal from the ACE spacecraft without disassembly of the instrument/sensor. Instruments/sensors shall be mounted to the spacecraft by means of mounting hardware passing through flanges located on the payload instruments/sensors. Mounting hardware shall be accessible from the top of each

FSCM NO. 88898	SIZE A	DWG. NO. 7345-9016
SCALE	DO NOT SCALE PRINT	SHEET 3-4

instrument/sensor. Special mounting hardware if required, shall be provided by the instrument/sensor experimenter.

3.2.2 Instrument Mounting Flange Specifications

Instrument mounting hole size, mounting bolt size, mounting bolt torque, mounting hole configuration, position tolerance, and mount flange planarity shall be detailed in Figure 3.2.2-1. The spacecraft shall supply standard ANSI mounting hardware only. Note: Minimum mounting plane flatness shall be 0.015" over the longest dimension. Minimum flatness shall be verified prior to integration.

3.2.3 Instrument Mounting Hardware Specification

Mounting bolt size and quantity for each sensor shall be determined in accordance with standard practice. Mounting bolt threads shall be American Unified SAE Threads per ANSI 81.1 - 1982. Thread tolerance shall be class 2A/2B.

3.2.4 Mounting Hole Location Tolerance

Mounting hole locations shall have positional tolerances which do not exceed 0.014 inches diametrical clearance at maximum material condition. Mounting bolt hole clearance diameters shall not exceed +0.005/-0.001.

3.2.5 Instrument Mounting Repeatability

All instruments which must be removed and replaced after optical axis alignment shall provide means of preserving alignment on repeated mountings. **The method of preserving alignment shall be documented in Figure 3.2.5-1.** This requirement applies to critically aligned instruments only.

3.3 ALIGNMENT

Alignment of the payload instrument/sensor optical Axes shall be accomplished by control of the instrument/spacecraft mounting interface. **Specific alignment requirements shall be documented in Figure 3.2.2-1.**

The shift of the optical axes location with respect to the spacecraft axes, when exposed to the environment outlined in the ACE Environments Specification APL 7345-9007, shall not be greater than that defined in the Specific Instrument Interface Specification for each payload instrument.

3.3.1 Definition of Spacecraft Axes

The spacecraft axes are defined in Figure 3.3-1.

3.3.2 Definition of Instrument/Sensor Optical Axes

The instrument/sensor optical axes are defined by the use of Figure 3.3-2.

FSCM NO. 88898	SIZE A	DWG. NO. 7345-9016
SCALE	DO NOT SCALE PRINT	SHEET 3-5

Figure 3.2.2-1 SWIMS Mounting Specification

Please see Mechanical Interface Drawing, A30001, sheet 2.

The SWIMS mounting hardware is inherited from the SOHO/CELIAS/MTOF instrument. The foot design is "quasi-isostatic" in order to afford mechanical compliance and thermal insulation, and incorporates stainless steel tubes that are swaged in place. The MTOF sensor is mounted with M5 bolts that have an 0.197 inch major diameter. The mounting holes in the feet are 0.208 ± 0.008 inches, which is somewhat larger than the closest Imperial hardware, #10-32 bolts with diameter 0.190 inch. Use of thick hardened steel washers will help alleviate these mounting problems. Please see the attached drawing (A20102) that details this washer.

We currently anticipate the use of eight (8) 6AL-4V Titanium alloy 10-32 x $1\frac{5}{16}$ SHCS screws which will be supplied by the SWIMS IDT.

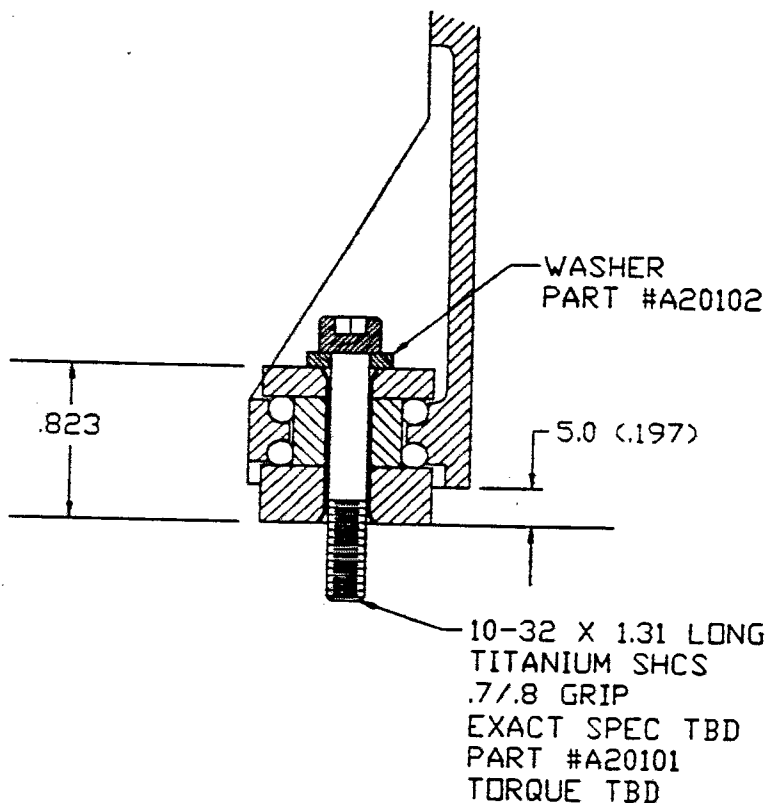

FSCM NO. 88898	SIZE A	DWG. NO. 7345-9016
SCALE	DO NOT SCALE PRINT	SHEET 3-6

Figure 3.2.5-1 SWIMS Instrument Mounting Repeatability

The SWIMS instrument alignment is not critical, and a tolerance of +/- 1 degree is acceptable. The eight (8) mounting bolt clearances provide this level of accuracy in angular alignment.

FSCM NO. 88898	SIZE A	DWG. NO. 7345-9016
SCALE	DO NOT SCALE PRINT	SHEET 3-7

Figure 3.3-1 Definition of Spacecraft Axes

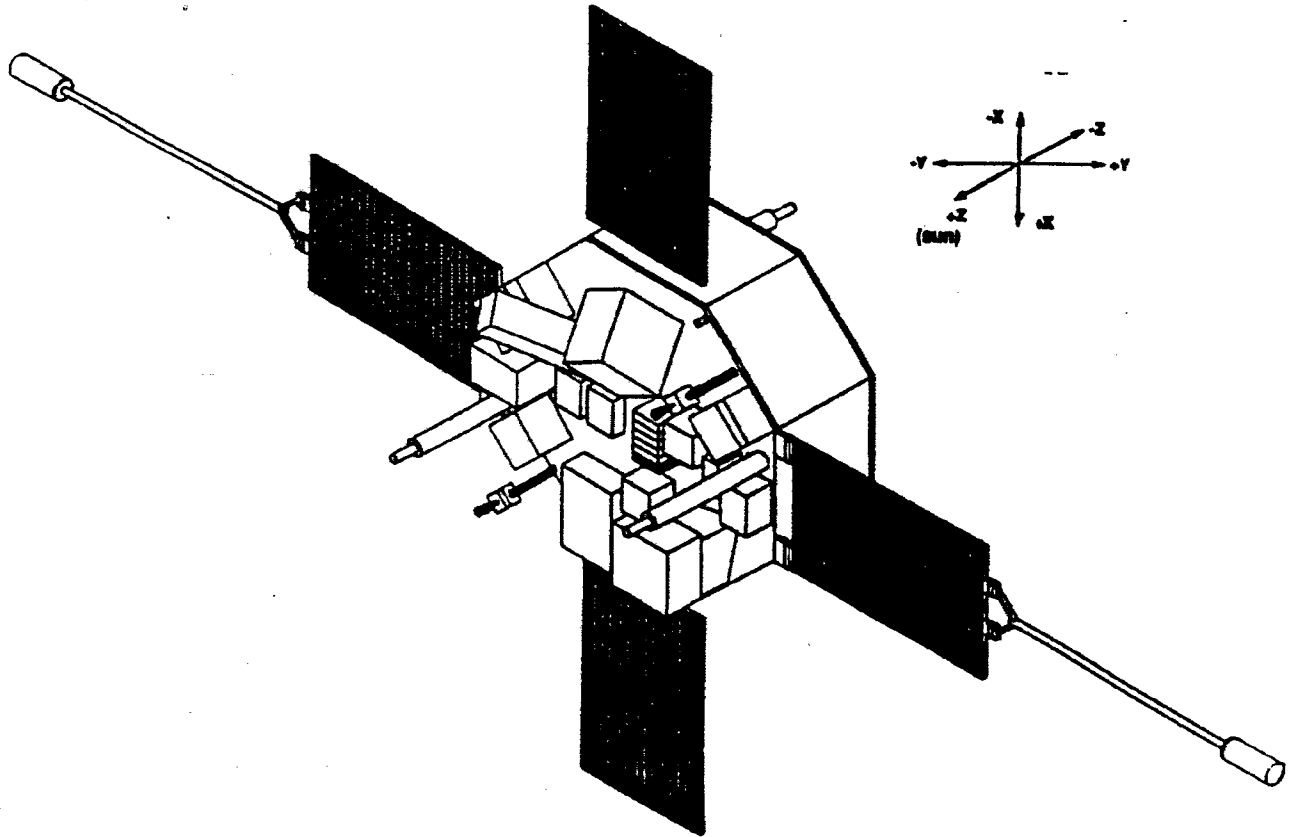

FSCM NO.	SIZE	DWG. NO.
88898	A	7345-9016
SCALE	DO NOT SCALE PRINT	SHEET 3-8

Figure 3.3-2 Definition of SWIMS Optical Axes

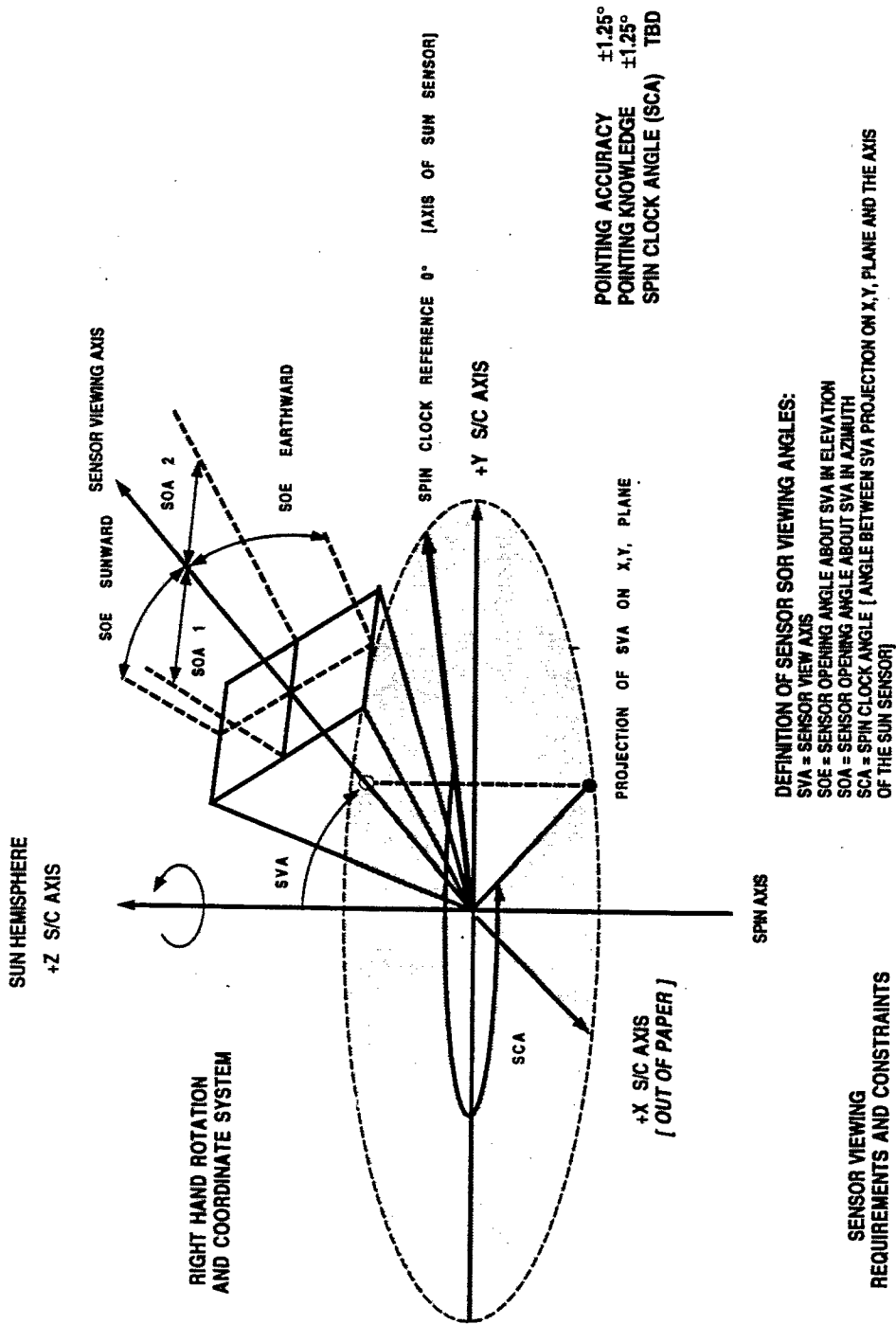

PRIMARY FIELD OF VIEW

SENSOR	SVA	SOE SUNWARD	SOE EARTHWARD	SOA 1	SOA 2
SENSOR ASSY.	5°	31°	31°	30°	30°

FSCM NO.	SIZE	DWG. NO.
88898	A	7345-9016
SCALE	DO NOT SCALE PRINT	SHEET 3-9

3.3.3 Alignment of Optical Axis

The alignment of the instrument/sensor optical axes shall be accomplished by positioning the mounting hole locations, on the spacecraft, with respect to the spacecraft coordinate system. The optical axes of the instrument/sensor shall be related to the instrument/sensor mounting hole pattern. The instrument/sensor experimenter shall measure the optical axis alignment with respect to the mounting hole pattern to verify the validity of the optical axis alignment.

3.4 **HARNESS TIE POINTS**

Harness tie points, if needed, on an instrument/sensor shall consist of individual cable clamps attached to the instrument/sensor, or lacing clips bonded with epoxy adhesive.

Payload instruments/sensors shall provide suitable cable clamp tie points or areas free from surface coatings suitable for the application of epoxy adhesive. **The tie points or bonding areas are shown in Figure 3.4-1 or on the mechanical drawings.** The spacecraft shall provide a general harness drawing.

3.5 **PAYLOAD INSTRUMENT/SENSOR LOAD DESIGN**

3.5.1 General

The payload instruments/sensors shall be designed to provide primary load paths from the sensor masses to the sensor mounting flange in the most direct path practical.

3.5.2 Load Directions

Payload instruments/sensors shall be designed to withstand static and dynamic loads in any direction as specified in the ACE Environments Specification; APL 7345-9007. Payload instruments/sensors shall be designed to the stiffness described in APL 7345-9007.

3.6 **PAYLOAD INSTRUMENT/SENSOR PROTECTIVE COVERS**

3.6.1 Non-Flight Protective Covers

Protective covers shall be provided, if necessary, with each payload instrument/sensor to preclude damage caused by the entrance of foreign particles to sensitive areas and the rigors of handling, spacecraft integration and bench testing. Protective Covers shall be easily accessible and removable at the launch site. All protective covers shall be color coded and labeled "NON-FLIGHT" or shall be red-tagged. Covers for all interface connectors shall also be provided.

3.6.2 Flight Covers and Doors

The deployment of flight covers and doors shall not cause disturbance to other instruments on the spacecraft by blocking radiators, solar panels or the field-of-view of other instruments. **All sensor covers, their operational description, and their deployment envelope shall be described and documented in this document and in Figure 3.6.2-1.**

FSCM NO. 88898	SIZE A	DWG. NO. 7345-9016
SCALE	DO NOT SCALE PRINT	SHEET 3-10

Figure 3.4-1 Location of SWIMS S/C Harness Tie Points

There are few locations on the SWIMS instrument where harness tie points may be attached. The acceptable points are identified on the SWIMS External Configuration Drawing A30001, sheets 1 and 3.

The "pyro" connector (A0410-J01) is approximately 2.5 inches above the deck, and a tie point on the side-panel near the purge fitting may be developed.

The purge fitting is less than 1 inch above the deck, so that any tie point required may be established on the deck in that vicinity.

The HV enable/disable connector (A0410-J03) has no harness attached to it, and needs no tie-points.

The Data and the Power connectors (A0410-J02 and -J04) are both very close to the deck so that tie-points may also be established on the deck for them.

FSCM NO. 88898	SIZE A	DWG. NO. 7345-9016
SCALE	DO NOT SCALE PRINT	SHEET 3-11

Figure 3.6.2-1 SWIMS Sensor Cover Data

The SWIMS instrument has a cover that will be opened once in flight, and stay attached to the unit. The geometry of the cover and its swing path are shown on the Mechanical Interface Drawing, A30001.

FSCM NO. 88898	SIZE A	DWG. NO. 7345-9016
SCALE	DO NOT SCALE PRINT	SHEET 3-12

3.7 PAYLOAD INSTRUMENT/SENSOR UNIQUE TOOLING AND HANDLING FIXTURES

3.7.1 Optical Tooling

Instruments/sensors which require unique optical equipment to define operational alignment shall provide the needed equipment prior to spacecraft integration. Equipment descriptions, designations, and alignment procedures shall be documented in the Figure 3.7.1-1.

3.7.2 Handling Fixtures

Handling fixtures shall be provided, for all instrument/sensors, by the instrument/sensor experimenter for all equipment which exceed 35 lbs. The handling fixtures shall be used to remove the instrument/sensor from the shipping container and for the installation of the instrument/sensor aboard the spacecraft. **Note: The handling fixture shall be proof tested to 2.5x the rated load. The period of certification shall be 1 year.**

3.8 PAYLOAD INSTRUMENT/SENSOR ACCESSIBILITY

All instrument/sensor experimenters shall identify the times, in the integration test flow, when access to their flight hardware is required. **The type of access, duration, test equipment required and procedures shall be documented in Figure 3.8-1.** After integration instruments shall not be removed except to repair faults or to accomplish prearranged (approved) calibration procedures.

NOTE: At some point (TBD) in the spacecraft integration, access to individual instruments/sensors may be prohibitively time consuming and/or expensive. Instruments shall provide information concerning access holes needed in thermal blankets.

3.9 PAYLOAD INSTRUMENT/SENSOR IDENTIFICATION AND MARKING

All flight hardware and shall be marked with appropriate (AXXXX) identification. The markings shall be permanent, resistant to chipping and located away from points of physical wear. Interface connectors, test points and adjustments shall be clearly labeled. (AXXXX-JXX). These "A" numbers shall be supplied by the spacecraft. **A list of instrument identification numbers is found in Figure 3.9-1**

3.10 PAYLOAD INSTRUMENT/SENSOR MAINTAINABILITY

The maintainability guidelines presented below shall be considered to the extent practical during all design efforts .

- a) Designs should avoid projecting parts which may be easily damaged during handling.
- b) Designs should be configured to stand alone in a stable manner.
- c) All design components which may be inadvertently reversed or misaligned during integration should be keyed.

FSCM NO. 88898	SIZE A	DWG. NO. 7345-9016
SCALE	DO NOT SCALE PRINT	SHEET 3-13

Figure 3.7.1-1 SWIMS Optical Tooling Requirements

No optical tooling, alignment procedure or handling fixtures are required.

FSCM NO. 88898	SIZE A	DWG. NO. 7345-9016
SCALE	DO NOT SCALE PRINT	SHEET 3-14

Figure 3.8-1 SWIMS Access Requirements

There are several times during system level tests that access to SWIMS will be necessary.

1. HV Test Preparation

The SWIMS high-voltages can only be operated in high-vacuum. It is assumed that there will be at least one opportunity to perform such a test once SWIMS has been integrated onto the spacecraft. In preparation for such a test, prior to pumpdown all four (4) red-tag vent plugs must be removed. In addition, the HV disable plug must be removed, and replaced with either another red-tag plug (for partial disabling of HV), or the green-tag HV enable plug.

If the aperture cover is to be opened by pyro (wax motor) during the test, then no preparation is required. If not, then the cover must be opened manually just prior to closing the chamber, in order to allow for proper outgassing of the instrument.

2. After HV Test

After the HV test, the cover must be closed as soon as possible to minimize contamination of the sensor. The four vent plugs must be re-installed, and the full disable plug must also be replaced.

3. MLI Installation

Thermal analysis of SWIMS is not complete, and it is not known to what extent MLI will cover the sensor. It has also not been determined when the MLI will be installed, although it is feasible that access to SWIMS may be required after integration onto the spacecraft for such a purpose.

4. Refurbishment

SWIMS must be removed from the spacecraft as late as possible in the launch campaign as possible for replacement of its detectors and for an associated calibration.

FSCM NO. 88898	SIZE A	DWG. NO. 7345-9016
SCALE	DO NOT SCALE PRINT	SHEET 3-15

Figure 3.9-1 Instrument Identification Numbers

INSTRUMENT	ID NUMBER	SENSOR A (-Y)	SENSOR B (+Y)
EPAM	A1100		
EPAM ADAPTER	A1101		
EPAM BRACKET	A1102		
MAGNETOMETER	A1050	A1430	A1470
ULEIS TELESCOPE	A1030		
ULEIS DPU	A1020		
ULEIS ANALOG	A1010		
SEPICA	A1040		
SWIMS	A0410		
SSSDPU	A1070		
SWICS	A1090		
SWEPAM ION	A1120		
SWEPAM ELECTRON	A1080		
CRIS	A0810		
SIS	A1060		

FSCM NO. 88898	SIZE A	DWG. NO. 7345-9016
SCALE	DO NOT SCALE PRINT	SHEET 3-16

- c) All design components which may be inadvertently reversed or misaligned during integration should be keyed.
- d) Instruments/sensors shall be designed to prevent ESD malfunctions caused by normal space laboratory handling and integration practices.

3.11 PAYLOAD INSTRUMENT/SENSOR STORAGE

Instruments/sensors shall be capable of being stored for at least 6 months under conditions of temperature and humidity specified in Figure 3.11-1 without requiring major repair, maintenance or recalibration. Any refurbishment requirements after storage shall be documented in Figure 3.11-2. Note: JHU/APL will supply N₂ and plumbing to the instrument purge connector for all off-line operations, which require purge, and for storage periods resulting from integration delays or other conditions.

FSCM NO. 88898	SIZE A	DWG. NO. 7345-9016
SCALE	DO NOT SCALE PRINT	SHEET 3-17

Figure 3.11-1 SWIMS Storage Requirements

Please refer to the "SWIMS Transport, Handling, and Storage Procedure", which will be supplied by the SWIMS IDT prior to the delivery of the instrument for integration.

FSCM NO. 88898	SIZE A	DWG. NO. 7345-9016
SCALE	DO NOT SCALE PRINT	SHEET 3-18

Figure 3.11-2 SWIMS Refurbishment After Storage

NONE REQUIRED

FSCM NO.	SIZE	DWG. NO.		
88898	A	7345-9016		
SCALE	DO NOT SCALE PRINT		SHEET	3-19

4.0 PAYLOAD INSTRUMENT/SENSOR THERMAL INTERFACE REQUIREMENTS

4.1 GENERAL

Note: In keeping with the concept of a combined GISS and SIIS the general thermal requirements of the GISS are included in this section. Specific instrument thermal interface requirements are shown in Figures and are referenced to the general GISS paragraph numbers.

Instrument/sensor thermal dissipation will be removed via conductive transfer to the spacecraft, radiative transfer from the instrument/sensor to its external surroundings, or a combination of both depending upon the nature of the thermal interface. Any instrument requiring radiative coupling to space will be able to greatly simplify its thermal design effort by maintaining an isolated interface with the spacecraft. An isolated interface is strongly urged for most instruments. Boxes with no apertures and requiring no space view may be conductively tied to the spacecraft and covered with MLI.

Thermal control systems aboard the spacecraft will ensure that the deck temperature at each instrument/sensor mounting location remains within the limits specified in the individual SIIS (Specific Instrument Interface Specification). To accomplish this task, the interface characteristic for each instrument must be included in the overall spacecraft thermal model

4.2 SPACECRAFT THERMAL DESIGN AND CONTROL

The ACE spacecraft consists of two honeycomb decks tied together by internal supports and honeycomb side panels. The two decks are octagonally shaped with four solar panels extending horizontally from the +X and +Y deck edges, facing the sun hemisphere. The spacecraft is spinning at approximately 5 rpm. The axis of rotation points to within 20 degrees of the sun.

The preliminary spacecraft thermal design environment is illustrated in Figure 4.2-1. The upper deck of the spacecraft is covered by thermal insulation to shield it from the sun as much as possible. Heat is rejected from the +Z forward deck via radiators which are attached to all eight edges of the octagon. The radiators face radially away from the axis of symmetry of the spacecraft. The size of the various radiators will be determined as the thermal design matures.

The spacecraft side panels are used primarily for mounting spacecraft components. However, the +X/-Y and -X/+Y panels have been allocated for the isolated mounting of the SWIMS and CRIS instruments, respectively. The spacecraft thermal design will minimize the heat exchange between individual side panels and space by enclosing all of the panels in thermal insulation blankets that extend from the bottom of the instrument deck radiators to the beginning of the aft deck attach flange. For the instruments mounted on the side panels, the insulation blankets will serve to radiatively isolate the instrument from the side panel. Sun sensor and Star Scanner apertures will not be covered with MLI.

The spacecraft aft deck serves as the mounting platform for the propulsion system. In addition, components of the RF subsystem are mounted to the space-facing side of the aft deck. The observatory attach fitting is bolted to the aft deck and will also be used as a thermal radiator. Thermal blankets will closeout the areas around the exposed antenna dishes.

FSCM NO.	SIZE	DWG. NO.
88898	A	7345-9016
SCALE	DO NOT SCALE PRINT	SHEET 4-1

Figure 4.2-1 Preliminary Spacecraft Thermal Design Environment

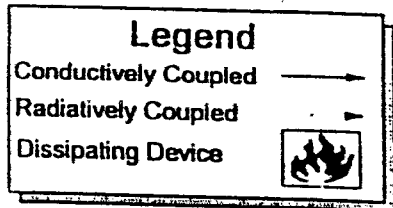

■ = Ultem Spacer
0.5" D, .375" High

Orbit Attach Flange
Part MLI / Part Radiator

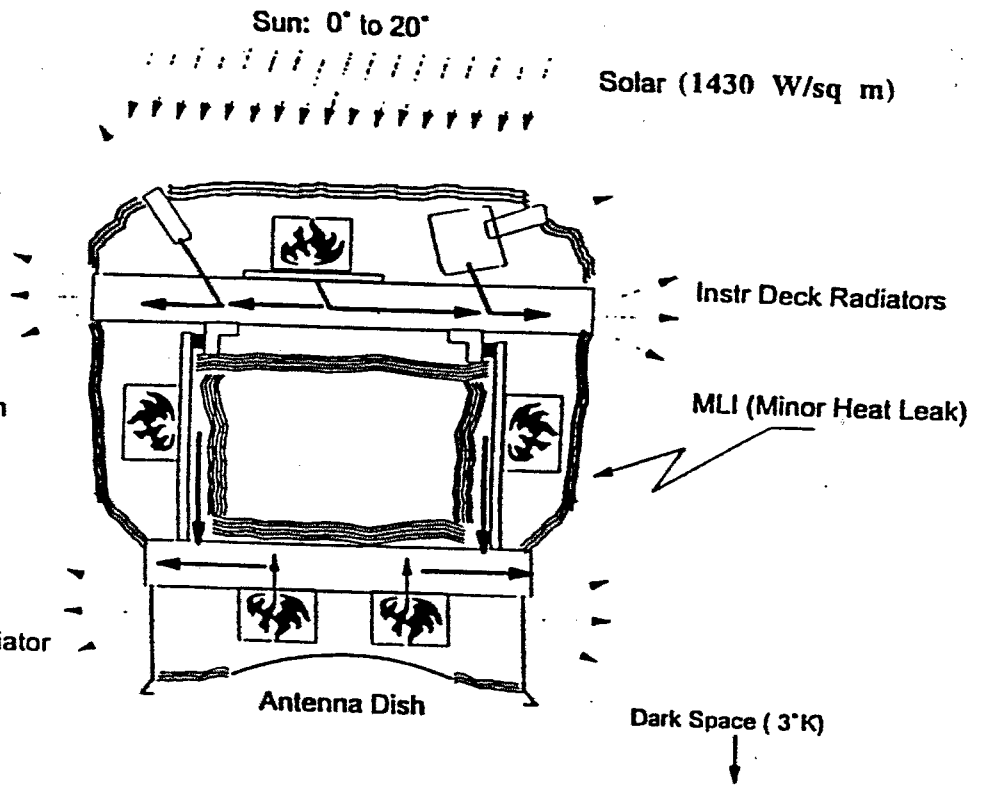

FSCM NO. 88898	SIZE A	DWG. NO. 7345-9016
SCALE	DO NOT SCALE PRINT	SHEET 4-2

The spacecraft will be thermally stable at the Earth-Sun libration point since there is very little variation in the thermal environment. The main cause of any thermal perturbations will be internal power fluctuations. However, customary thermal analysis techniques require that many of the thermal design parameters be allowed to vary between hot and cold cases to ensure that the design is robust. Therefore, for a spacecraft which is expected to be in a stable environment, the resultant predicted temperature variations and heater power requirements are primarily driven by the degree of variation in the thermal parameters.

Incident external environmental fluxes are included in Figure 4.2-1 for use by the instrument thermal engineers. The flux values are assumed to be averaged over the spin of the ACE spacecraft. At 5 rpm, transient effects are expected to be minimal.

4.2.1 Spacecraft-Instrument Interface Temperatures

The interface temperatures specified for the instruments and their components are always assumed to be on the spacecraft side of the interfaces. A protoflight design and test interface range is specified for each instrument depending on its type of mounting. The instrument must be capable of maintaining the temperature of all its components within the operational ranges given in the SIIS while the deck interface temperature is within the design/test range. The design/test interface temperature range is 5° C outside of the spacecraft operating range. In addition, a survival range is specified for each instrument interface. While the observatory is in survival mode, i.e., all instruments off and spacecraft in survival mode, each instrument must maintain the temperature of its components within the survival ranges given in the SIIS.

For cases in which one or more instruments are powered off while the spacecraft is still in operational mode, instrument interface temperatures will be maintained within operational limits by interface heaters located on the deck. Under these circumstances, the ACE Observatory is still defined as being in operational mode. For analysis, instruments should always use the spacecraft design/test temperature range of their interfaces.

The instruments should recognize the difference between the interface temperature ranges specified in Section 4.2.1 and the various temperature ranges specified in the SIIS. The interface temperatures should be used as inputs to the instrument thermal models. For an isolated instrument, the interface temperature should, by design, have little impact on its internal component temperatures. An instrument with a conductively coupled interface will have a greater dependence on interface temperature, but, only as a more significant input to its thermal model. The interface ranges are not specifically required to fall within any component range defined for an instrument. However, the definition of the interface temperature ranges for an instrument is consistent with the requirements of its responsible thermal engineer.

The spacecraft is responsible for the transition of interface temperatures from survival to operational mode. However, each instrument is responsible for transitioning its components from survival to turn-on, given that the interface temperatures shall be within the design/test range specified in this section. The simplest approach is for an instrument to define its minimum survival and turn-on temperatures to be the same, if possible.

Control of Observatory deck temperatures at the instrument mounting locations will depend on the choice of individual mounting configurations. Instrument sensors which require a

FSCM NO. 88898	SIZE A	DWG. NO. 7345-9016
SCALE	DO NOT SCALE PRINT	SHEET 4-3

thermally conductive interface with the deck can expect a design/test range of -15°C to $+15^{\circ}\text{C}$ and a survival range of -25°C to $+15^{\circ}\text{C}$ on the spacecraft side of the interface. These ranges are consistent with the instrument temperature requirements defined in each SIIS and should be used for instrument thermal analyses. Instrument sensors with thermally conductive interfaces have a direct effect on spacecraft thermal design. Therefore, the demands placed by the spacecraft on instruments with thermally conductive interfaces are more severe than for those instruments with isolated interfaces.

Instrument electronics boxes that require thermally conductive interfaces with the deck will be treated as general electronics unless,

- a) The box cannot be thermally separated from its sensor; or,
- b) The box has component limitations preventing exposure to the typical design range for general electronics.

General electronics boxes have a design/test temperature range of -23°C to $+55^{\circ}\text{C}$ at their mounting interfaces. The survival temperature range is also defined as -23°C to $+55^{\circ}\text{C}$. Instrument electronics boxes which cannot be treated as general electronics must negotiate their interfaces with the spacecraft thermal engineer. Allowable temperature ranges shall be included in the appropriate SIIS.

Instruments which are isolated from the deck have only a minor effect on spacecraft thermal design and are less sensitive to the interface temperature. Interface temperatures for isolated instruments shall have a design/test range of -20°C to $+40^{\circ}\text{C}$. The survival range shall be -25°C to $+40^{\circ}\text{C}$ on the spacecraft side of the interface. These ranges are consistent with the temperature requirements defined in the SIIS for each isolated instrument and should be used in the instrument thermal analyses.

Instruments mounted to the ACE side panels will be exposed to a design/test interface temperature range of -10°C to 40°C . During the Observatory survival mode, instrument interfaces on the side panel will be maintained within the same range of -10°C to $+40^{\circ}\text{C}$.

Instruments mounted to the aft deck will be exposed to an design/test interface temperature range of -10°C to $+45^{\circ}\text{C}$. During the Observatory survival mode, instrument interfaces on the aft deck will be maintained at the same range of -10°C to $+45^{\circ}\text{C}$. Specific instrument interface temperature information is found in Figure 4.2.1-1

4.3 Instrument Sensor Thermal Design and Control

The instrument/sensor experimenters shall be responsible for the thermal design of their instruments/sensors. The primary methods of thermal control available to the instrument/sensor designers are illustrated in Figure 4.3-1 and are described below. **Figure 4.3-2 illustrates the specific instrument thermal control methods.** The choice of thermal control method will be made by the spacecraft thermal engineer in conjunction with the instrument/sensor engineer. For all methods of thermal control, the instrument thermal engineer must take into account the allowable deck temperatures on the spacecraft side of the thermal interfaces.

- a) **Local Thermal Control:** Thermal dissipation is radiated directly from the external instrument/sensor surfaces to space. All non-radiator surfaces must be radiatively isolated from the spacecraft and other instruments. In addition, the instrument must be conductively isolated from the spacecraft. The instrument thermal engineer must be able to show, by analysis, a thermal interface resistance of $\geq 20^{\circ}\text{C/W}$. Finally, the

FSCM NO. 88898	SIZE A	DWG. NO. 7345-9016	
SCALE	DO NOT SCALE PRINT		SHEET 4-4

Figure 4.2.1-1 SWIMS Interface Temperature Data

The SWIMS instrument is thermally isolated from the S/C deck. Interface temperature requirements are shown in Table 4.2.1-1.

Table 4.2.1-1 SWIMS/Spacecraft Interface Temperatures

Component	Operational Temp. Range	Survival Temp. Range
SWIMS	-20 to +40°C	-25 to +40°C

FSCM NO. 88898	SIZE A	DWG. NO. 7345-9016
SCALE	DO NOT SCALE PRINT	SHEET 4-5

Figure 4.3-1 Typical Instrument/Sensor Thermal Control Methods

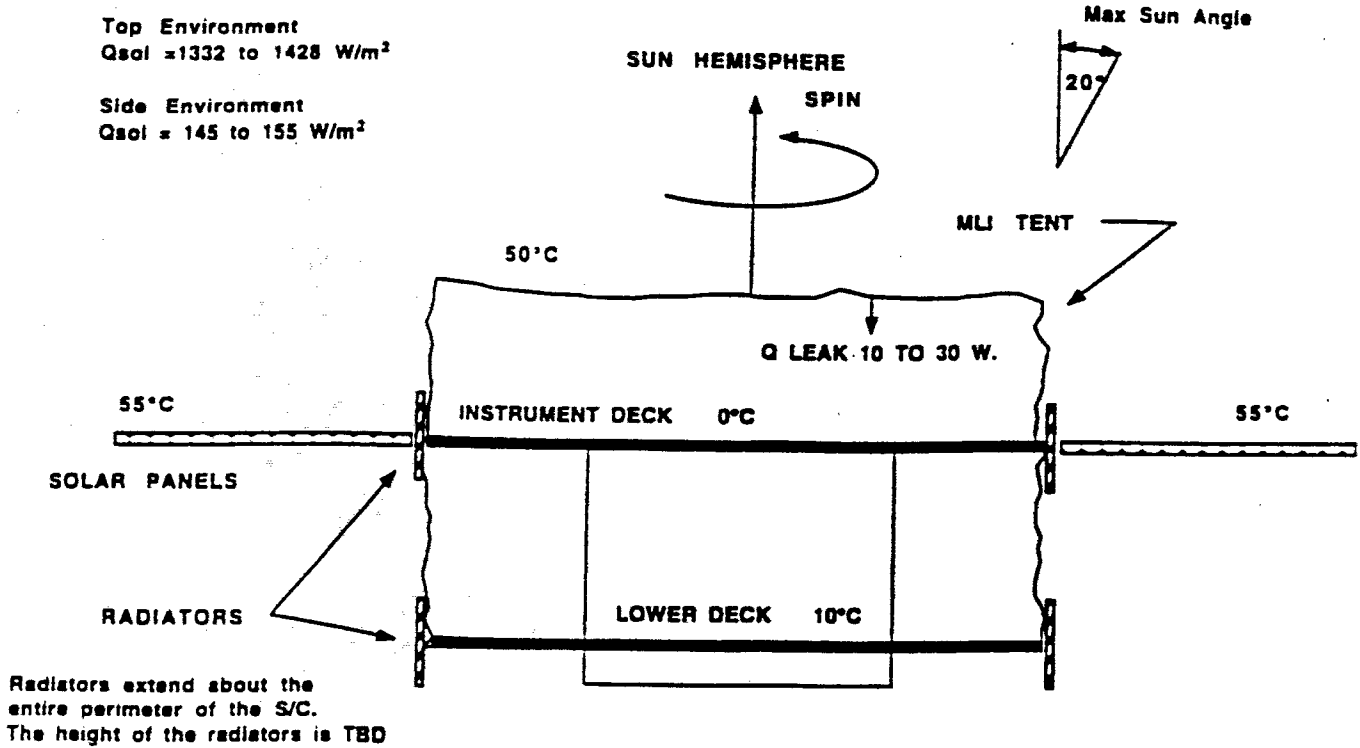

FSCM NO.	SIZE	DWG. NO.
88898	A	7345-9016
SCALE	DO NOT SCALE PRINT	SHEET 4-6

Figure 4.3-2 SWIMS Thermal Control Method

Thermal dissipation for the SWIMS instrument is radiated directly to space via radiators mounted on the SWIMS instrument. Mechanical mounts and electrical bond wires shall provide a minimum thermal resistance of 20°C per Watt.

FSCM NO. 88898	SIZE A	DWG. NO. 7345-9016
SCALE	DO NOT SCALE PRINT	SHEET 4-7

design placement of local radiators, if required to remove localized heat, must be coordinated with the spacecraft thermal engineer.

- b) **Central Thermal Control:** Thermal dissipation is conducted from the instrument/sensor to the observatory deck for eventual rejection to space. Candidates for central control include support electronics that have no apertures and which can be thermally decoupled from the sensor sections that require extended temperature ranges. Use of central thermal control requires approval of the spacecraft thermal engineer.
- c) **Hybrid Thermal Control:** Thermal dissipation is removed from the instrument/sensor via a combination of radiation to the environment and conduction to the observatory deck. The use of hybrid thermal control is undesirable because of analysis difficulties. Instruments desiring hybrid control must demonstrate the necessity of its use and be prepared to work very closely the spacecraft thermal engineer if its use is allowed.

In any case, the thermal design of the instruments/sensors will require cooperation between the instrument/sensor thermal engineer and the spacecraft engineer. It is important that liaison between instrument/sensor designers and the spacecraft designers begins as early in the design phase as possible.

4.4 PAYLOAD INSTRUMENT/SENSOR SPACE ENVIRONMENT TEMPERATURE LIMITS

The allowable instrument/sensor orbital temperature limits shall be established by the experimenter and documented in Figure 4.4-1. Instrument thermal models, delivered to the spacecraft, must include nodes for all critical temperatures defined in Figure 4.4-1. As a minimum, the following limits shall be specified at the appropriate control locations:

- a) **Operating Limits:** Temperature range within which each instrument/sensor must meet its operating specifications. For instruments utilizing Local Thermal Control, the operating limits must be specified at control surfaces, usually the radiators. Limits must also be given for critical components within the instrument and for acceptable deck interface temperatures. For instruments utilizing Central Thermal Control, operating limits must be specified at the spacecraft side of the interface between the instrument and the deck. Limits for critical components must also be specified. For instruments utilizing Hybrid Thermal Control, operating limits must be specified for all control locations and for critical components.
- b) **Survival Limits:** Widest temperature range that each instrument/sensor can undergo in an unpowered state without damage or performance degradation. Survival limits must be specified at the appropriate thermal control locations as defined above for Operating Limits.

FSCM NO. 88898	SIZE A	DWG. NO. 7345-9016
SCALE	DO NOT SCALE PRINT	SHEET 4-8

Figure 4.4-1 SWIMS Instrument Temperature Limits

COMPONENT	IN-SPEC	DESIGN/TEST	SURVIVAL
ELECT. AND P.S.	-30 TO +40 °C	-35 TO -55 °C	-40 TO +60 °C
MCP	-30 TO +30 °C	-30 TO +40 °C	-25 TO +40 °C
VEE, HYP	-30 TO 0 °C	-30 TO +40 °C	-40 TO +40 °C

FSCM NO. 88898	SIZE A	DWG. NO. 7345-9016
SCALE	DO NOT SCALE PRINT	SHEET 4-9

- c) **Turn-on Limits:** Widest temperature range within which each instrument/sensor must be capable of turning on without damage or performance degradation of any kind. The instrument is-not necessarily required to operate within design specifications at the turn-on limits. However, once the instrument is within the specified operating limits, full compliance with design specifications is required. In most cases, the turn-on temperature range should be the same as the survival temperature range.

4.5 OBSERVATORY TEST TEMPERATURE LIMITS

Observatory thermal and thermal vacuum test limits are documented in APL 7347-9007. The instruments/sensors shall survive and not suffer damage or performance degradation after exposure to the specified limits. In general, temperature variations at the interfaces of the instruments are given by the design/test limits. Under no circumstances shall the temperature on the spacecraft side of the interface be allowed to exceed the corresponding instrument interface design/test limits defined here and in section 4.2.1

4.6 TEMPERATURE SENSOR LOCATIONS

The spacecraft integration team will mount temperature sensors to the baseplate of each instrument/sensor in order to monitor the interface temperature. The temperature sensors will be provided and located by the spacecraft designers. **The location of each temperature sensor shall be depicted on the instrument/sensor interface control drawing and documented in Figure 4.6-1.**

4.7 PAYLOAD INSTRUMENT/SENSOR THERMAL MODEL ANALYSIS

4.7.1 Thermal Model

A reduced thermal model of each instrument/sensor shall be provided by the instrument/sensor thermal engineer for inclusion in the overall spacecraft thermal model. The number of nodes in each model shall be consistent with the thermal complexity. Simple systems may have as few as three nodes. The models should include nodes for all critical components. Thermal models shall be provided in the SINDA format.

After integration with the spacecraft thermal model, the reduced instrument thermal models will be used by the spacecraft thermal engineer to predict instrument temperatures. Therefore, the reduced models should correlate well with the detailed instrument thermal model in the areas of heat transfer across the spacecraft interface, heat transfer with the space environment, and critical component temperatures. In addition, detailed instrument thermal models must be validated during some phase of thermal vacuum testing. If the instrument sponsors do not require qualification testing in vacuum, then, the interfaces cannot be validated until the observatory level thermal vacuum test. At that point, each instrument risks the possibility that its interface will differ significantly from that of the thermal model. Since the instrument models will be relied upon to define thermal control requirements of the instrument deck and surrounding surfaces, a significant error in the models could limit the thermal control available during flight. **Specific instrument thermal model information is defined in Figure 4.7.1-1.**

FSCM NO. 88898	SIZE A	DWG. NO. 7345-9016
SCALE	DO NOT SCALE PRINT	SHEET 4 10

Figure 4.6-1 Location of Spacecraft Supplied Temperature Sensors

There will be a spacecraft supplied temperature sensor attached to the SWIMS base plate in a location determined by the IDT and the SDT at the time of integration.

FSCM NO. 88898	SIZE A	DWG. NO. 7345-9016
SCALE	DO NOT SCALE PRINT	SHEET 4-11

Figure 4.7.1-1 SWIMS Thermal Model Information

SWIMS IDT shall provide a instrument thermal model directly to the spacecraft thermal engineer.

FSCM NO. 88898	SIZE A	DWG. NO. 7345-9016
SCALE	DO NOT SCALE PRINT	SHEET 4-12

4.7.2 Geometry Model

Experimenters shall provide, to the spacecraft, geometric models of their instruments in SSPTA format, for inclusion in the overall spacecraft geometric model. In return, the spacecraft will provide flux information for each surface of the model to the instrument/sensor designers for use in their detailed thermal modeling effort.

Geometric models shall be delivered to the spacecraft no later than June 7, 1993 to allow adequate time for incorporation into the spacecraft models prior to PDR. Updated models shall be delivered to the spacecraft no later than March 1, 1994 to allow adequate time for analysis prior to the spacecraft CDR.

4.8 THERMAL CONTROL DEVICES

Special thermal control devices required by an instrument shall be defined and described in the SIIS. The primary concern is for devices that will have some affect on the thermal interface between an instrument and the spacecraft.

4.8.1 Heaters

There are three classes of heaters that are of concern to the instruments/sensors aboard the ACE Observatory: interface, operational, and survival **The instrument heater capacities are the peak power requirements for the operational, interface, and survival heaters shown in Figure 4.8.1-1**

Interface heaters are mounted on the ACE experiment deck and are used to augment the instrument deck operational heaters during times when one or more instruments are turned off. The interface heaters replace some of the dissipation lost when an instrument is turned off. Sizing and placement of the interface heaters is the responsibility of the spacecraft thermal engineer. The heater power is allocated from the spacecraft power budget. The interface heater design effort cannot be completed until all of the final instrument thermal models have been incorporated into the spacecraft thermal model. The interface heaters are of primary importance to the instruments that utilize central thermal control. Instruments utilizing local thermal control are less affected by changes in deck temperature because of low thermal conduction in the interface.

The two remaining types of heaters, operational and survival, fall within the domain of the instrument thermal engineer. The instrument operational heaters are intended to support internal temperature requirements and can be used during normal instrument operation. The use of operational heaters is optional and the heater power will be allocated from the instrument power budget. Since the majority of the instruments are baselining a thermally isolated design, it may be necessary for the spacecraft to provide some additional instrument operational heater power. This will only be possible if the spacecraft deck temperature limits are as indicated in Section 4.2.1.

The ability of the spacecraft thermal engineer to provide additional operational heater power to the instruments will depend on the outcome of the overall spacecraft thermal analysis which will include all of the instrument thermal models. If additional operational heater power is required, the instrument thermal engineer must work with the spacecraft thermal engineer to define the requirement.

FSCM NO. 88898	SIZE A	DWG. NO. 7345-9016
SCALE	DO NOT SCALE PRINT	SHEET 4-13

Figure 4.8.1-1 SWIMS Thermal Control Devices

The SWIMS instrument contains operational and survival heaters. There is also an interface heater installed by the S/C design team on the S/C deck.

See page 2-39 and Drawing Number 7345 - 2218 for heater information and connector pin-outs.

FSCM NO. 88898	SIZE A	DWG. NO. 7345-9016
SCALE	DO NOT SCALE PRINT	SHEET 4-14

Additional operational heater power will only be provided if the instrument thermal engineer can show that no other reasonable means can be used to control the instrument within its operational limits. This heater power is not for use in place of operational heaters already defined in the instrument design. Finally, if the final instrument analysis shows that the additional heater power will not be used, it will be reallocated to the spacecraft heater power budget.

The instrument survival heaters support internal temperatures during periods in which the instrument is in a powered off state. However, when an instrument is off, its operational power will be reallocated to the spacecraft power budget, specifically for the observatory deck interface heaters. Since only part of the instrument power budget will be used for interface heaters, there will be power available for instrument survival heaters. However, the instrument thermal engineer must coordinate the use of internal survival heaters with the spacecraft thermal engineer. Instrument survival heater power will be charged against the spacecraft power budget but cannot exceed the instrument operational power budget less the amount reserved for interface heaters.

FSCM NO. 88898	SIZE A	DWG. NO. 7345-9016
SCALE	DO NOT SCALE PRINT	SHEET 4-15

5.0

PAYLOAD INSTRUMENT/SENSOR MAGNETIC INTERFACE REQUIREMENTS

The ACE Observatory includes a sensitive magnetometer. Residual magnetic fields from the payload instrument/sensors and the spacecraft subsystems must be kept to a minimum by using standard magnetic cleanliness guidelines which include: minimum use of magnetic materials, power feed and return line twisting, compensation techniques, grounding, battery placement and solar panels with back wiring and other magnetic field reduction techniques.

There is a goal of achieving an Observatory residual magnetic field, at the Magnetometer sensor(s) position, which is less than 0.1 nT. The goal for AC interference, at the Magnetometer sensor(s) location, is less than 0.001 nT over a frequency range of 0 to 10 Hz and the specific frequencies of 15 kHz (± 200 Hz), 30 kHz (± 200 Hz) and 60 kHz (± 200 Hz).

Guidelines for reducing magnetic fields are given in the Environmental Specification, 7345-9007.

5.1 **INSTRUMENT/SENSOR DEGAUSSING**

Currently, there are no plans to degauss hardware at JHU/APL prior to integration with the spacecraft.

5.2 **INSTRUMENT MAGNETIC FIELDS**

Any instrument/sensor which generates a magnetic field shall specify the level and nature of the field in Figure 5.2-1.

FSCM NO. 88898	SIZE A	DWG. NO. 7345-9016
SCALE	DO NOT SCALE PRINT	SHEET 5-1

Figure 5.2-1 SWIMS Magnetic Field Properties

Instrument Magnetics

The SWIMS has no permanent magnets. The use of magnetic materials is limited to a few inductor cores. All connectors and mounting hardware are of materials with low residual magnetic properties. The generated field measured at 1 meter is ≤ 0.30 nT; the AC component is below detectable levels.

Instrument Degaussing

If degaussing is required the SWIMS will suffer no ill effects with degaussing fields less than 100 gauss.

FSCM NO. 88898	SIZE A	DWG. NO. 7345-9016
SCALE	DO NOT SCALE PRINT	SHEET 5-2

6.0 **PAYLOAD INSTRUMENT/SENSOR ELECTROMAGNETIC
INTERFACE REQUIREMENTS**

6.1 **PROGRAM REQUIREMENTS**

6.1.1 **Objectives**

All electronic components of the ACE Observatory must operate in electromagnetic harmony. The object of the Observatory EMI/EMC program is to verify compatibility of the payload sensors with each other, the spacecraft subsystems, and the launch site environment.

The Observatory shall conform to MIL-STD-461B, Part 3, Class A2a, tailored for the ACE mission. The specific requirements are given in the ACE Environmental Specification APL 7345-9007. The Observatory shall be tested in accordance with MIL-STD-462, tailored to the ACE mission.

FSCM NO. 88898	SIZE A	DWG. NO. 7345-9016
SCALE	DO NOT SCALE PRINT	SHEET 6-1

7.0

ENVIRONMENTAL INTERFACE REQUIREMENTS

The environments that the instruments/sensors will be exposed during all phases of the ACE mission, including ground handling, storage, integration, testing, transportation, launch and flight operations are described in the ACE Environment Definition, spacecraft and Observatory Test Requirements and Instrument Test Recommendations Document, APL 7345-9007. **Any deviation from the guidelines in aforementioned specification shall be presented in detail in Figure 7.0-1.** Instruments shall be designed to withstand electrostatic discharge (ESD) possible during packing and unpacking, transportation, and integration.

FSCM NO. 88898	SIZE A	DWG. NO. 7345-9016
SCALE	DO NOT SCALE PRINT	SHEET 7-1

Figure 7.0-1 Deviations from ACE Environments and Test Requirements Specification

**SWIMS will conform to the ACE Payload Enviromental Design and Test Requirements:
ACE-CT-100-22. No exceptions taken.**

FSCM NO. 88898	SIZE A	DWG. NO. 7345-9016
SCALE	DO NOT SCALE PRINT	SHEET 7-2

8.0 **PAYLOAD INSTRUMENT/SENSOR CONTAMINATION CONTROL**

8.1 **GENERAL**

The contamination requirements for each of the payload instruments/sensors shall be documented in Figure 8.1-1. Prior to integration, the instrument/sensor experimenters shall verify the cleanliness levels of all sensitive surfaces. The test methods shall be identified by the experimenter.

The following chemicals are prohibited in the integration and Observatory test areas:

- a) Aromatic Hydrocarbons
- b) Acetone
- c) Methyl Ethyl Ketone
- d) Propyl Alcohol
- e) Xylene
- f) Acetylene
- g) Vacuum pump oil and oil vapor
- h) Ammonia
- i) Caustic or acid fumes
- j) Mercury
- k) Ionic Salts
- l) TBD.

8.2 **PURGING**

If required, instruments/sensors will be provided, throughout the integration and test phases at JHU/APL and the launch site, a nearly continuous flow of dry filtered nitrogen distributed through Teflon FEP tubes. Purge will be interrupted during thermal-vacuum testing and certain ground handling procedures. Instrument/sensor test teams will be notified in advance of interruptions lasting longer than the times specified in the Specific Instrument Interface Specification. Purge shall be provided until the observatory is disconnected from the umbilical at lift-off. The instrument/sensor designer is responsible for the design of the purge system within their instrument/sensor.

8.2.1 **Purge Connectors**

Instruments/sensors, which require continuous purging from the spacecraft purge manifold, shall use the following purge fitting: SWAGELOCK SS-400-X-X.

FSCM NO. 88898	SIZE A	DWG. NO. 7345-9016
SCALE	DO NOT SCALE PRINT	SHEET 8-1

Figure 8.1-1 SWIMS Contamination Requirements

- 1) Handle only with gloves
- 2) Use only ethyl or iso-propol alcohol for cleaning
- 3) No chemicals or solvents in instrument vicinity without prior approval
- 4) Red tag covers must be installed prior to any cleaning
- 5) Constant purge (nitrogen) to instrument via swagelock purge fitting

FSCM NO. 88898	SIZE A	DWG. NO. 7345-9016
SCALE	DO NOT SCALE PRINT	SHEET 8-2

8.2.2 **Purge Gas Flow Rate**

Determination of the purge gas flow rate shall be the responsibility of the instrument/sensor experimenter. The necessary purge gas flow rate shall be controlled by the use of a restrictor integral with the purge connector or contained within the instrument/sensor. **Purge gas flow rate and restrictor information shall be documented in Figure 8.2.2-1.** The S/C purge manifold will be regulated at 3 psi. The maximum gas pressure is limited to 5 psi.

8.2.3 **Materials Outgassing**

Polymeric materials used in the instrument/sensor design shall conform to the requirements of the ACE Performance Assurance Implementation Requirements. **Exceptions and additions to these outgassing requirements shall be documented in Figure 8.2.3-1.**

FSCM NO. 88898	SIZE A	DWG. NO. 7345-9016
SCALE	DO NOT SCALE PRINT	SHEET 8-3

Figure 8.2.2-1 SWIMS Purge Requirements

SWIMS Instrument purge fitting is SWAGELOCK SS-401-1-2.

INST.	GAS	FLOW RATE	PURITY	TEMP.	TIME
SWIMS	NITROGEN	0.50 l/m	99.998%	+20±5°c	Until umbilical separation

FSCM NO. 88898	SIZE A	DWG. NO. 7345-9016
SCALE	DO NOT SCALE PRINT	SHEET 8-4

Figure 8.2.3-1 Exceptions or Additions to General Outgassing Requirements

SWIMS takes no exceptions.

FSCM NO. 88898	SIZE A	DWG. NO. 7345-9016
SCALE	DO NOT SCALE PRINT	SHEET 8-5

9.0 PAYLOAD INSTRUMENT/SENSOR GROUND SUPPORT EQUIPMENT

9.1 GENERAL

Ground support equipment (GSE) used for integration testing and prelaunch operations is the experimenter's responsibility and shall demonstrate compliance with the provisions of this document including contamination control, ground handling and storage.

The instrument/sensor GSE shall be capable of:

- a) verifying that the instrument/sensor has survived shipment and is ready for integration.
- b) accepting and processing the Observatory telemetry and science data downlink in real time and performing engineering analysis necessary to verify the successful operation of the instrument during all levels of Observatory testing.
- c) provide any required external stimulus.

9.2 INTERFACE

All GSE interfaces between the instrument/sensor and the ACE Observatory shall be documented in Figure 9.2-1. The GSE shall not interface directly with any spacecraft subsystem. Any GSE interface with the instrument shall be buffered and not have any impact on the S/C interfaces.

9.2.1 Telemetry Interface

The ACE Observatory GSE Interface and Test Operation Control Center (ITOCC) will provide the full S/C telemetry stream to each Payload GSE.

9.2.2 Command Interface

The ACE Observatory GSE (ITOCC) will provide serial interfaces for inputs from instrument GSEs to synchronize instrument/sensor testing with the instrument/sensor stimulus configuration.

9.2.3 Sun Sensor Interface

The ACE Observatory will provide buffered outputs of the Sun Pulse and the Spin Clock for instrument/sensor GSE synchronization.

9.3 GENERAL DESIGN FEATURES

The design and material construction of the GSE should incorporate the following features:

FSCM NO. 88898	SIZE A	DWG. NO. 7345-9016
SCALE	DO NOT SCALE PRINT	SHEET 9-1

Figure 9.2-1 SWIMS GSE Interface

N/A . GSE service through the S3DPU GSE

FSCM NO. 88898	SIZE A	DWG. NO. 7345-9016
SCALE	DO NOT SCALE PRINT	SHEET 9-2

- a) EMC Shielding
- b) Low Contamination Potential
- c) Easily Transportable (if necessary, provide I-bolts for the overhead crane)
- d) Ability to Test Instrument/Sensor on the Bench and After Observatory Integration.

9.3.1 Power

The instrument GSE shall not draw power from the spacecraft power systems; nor shall it provide power to the S/C unless the designer has first obtained written approval from the JHU/APL Program Office. Instrument/Sensor providers shall provide information on power requirements prior to delivery to the integration facility.

9.3.2 Identification and Marking

GSE equipment shall be clearly marked with the following information:

- a) Name of Assembly.
- b) Part number.
- c) Serial number.
- d) Manufacturer.
- e) Power requirements.
- f) Instrument name.

9.3.3 Calibration

The calibration of the GSE shall be the responsibility of the payload instrument/sensor experimenter. Spares, consumables and field replaceable critical components shall be defined and documented in the SIIS.

9.3.4 Documentation

The instrument/sensor GSE is the only equipment which is able to analyze the unique instrument/sensor data and operation characteristics. The GSE must therefore be included in the Observatory test and calibration procedures. The provider shall supply the following documentation for Observatory level testing:

- a) Specifications
- b) Set-up Procedures
- c) Safety Requirements, Operation Limits and Constraints

9.3.5 Radioactive Sources

Radioactive sources required during integrated system tests, thermal vacuum tests and pre-integration acceptance tests shall be provided by the instrument/sensor providers and shall conform to all relevant U.S. Government, State of Maryland, and JHU/APL procedures for possession and use.

FSCM NO. 88898	SIZE A	DWG. NO. 7345-9016
SCALE	DO NOT SCALE PRINT	SHEET 9-3

Each instrument radioactive source shall be identified by isotope name, activity, emitted particles and energy and shall be documented in Figure 9.3.5-1.

9.3.6 Thermal Vacuum Testing

Any non-flight hardware required inside the TV Chamber to support TV tests shall be approved by the spacecraft Integration and Test Engineer and shall meet the outgassing requirements of this document.

FSCM NO. 88898	SIZE A	DWG. NO. 7345-9016
SCALE	DO NOT SCALE PRINT	SHEET 9-4

Figure 9.3.5-1 SWIMS Radioactive Source List

SWIMS uses no radioactive test sources

FSCM NO. 88898	SIZE A	DWG. NO. 7345-9016
SCALE	DO NOT SCALE PRINT	SHEET 9-5

10.0 SPACECRAFT CABLE RESPONSIBILITIES

10.1 GENERAL POLICY

Consistent with past programs, the spacecraft does NOT provide any intra-instrument cabling (between instrument components) as part of the spacecraft harness responsibility. For instruments with more than one component, the spacecraft will be responsible for positioning these components and for routing any cabling between the components. The Instrument/Sensor experimenters shall provide all connecting cabling within their instrument subsystem.

10.2 INSTRUMENT CONCERN ON INTRA-INSTRUMENT CABLING

Several instruments will have more than one component within their instrument subsystem. This particularly applies to the instruments being served by an external DPU, with the DPU functioning as one of the "components" for several instrument subsystems. Meanwhile, the deck layout will be governed by many constraints, including FOV, magnetics, center of gravity, and so on, which could force the "components" of an instrument subsystem to be nonadjacent. In addition, minor changes in positioning may be needed late in the program to accommodate things such as refinement of component mass and cg, etc., as they are received. The spacecraft is responsible for routing the cabling between instrument components when they are distributed. This routing determines the cable length which the instruments would then have to provide. Several of the instruments expressed concern over providing cables between their instrument components in this type of scenario. A request has been made for the spacecraft to provide certain flight intra-instrument cables as part of the spacecraft harness. This request is reasonable, and the spacecraft will satisfy this request, under the stated conditions below. The spacecraft also has concerns regarding this new interface, but with properly handled agreements as described below, all parties should be satisfied.

10.3 CONDITIONS FOR GENERAL POLICY EXCEPTIONS

The spacecraft can only provide flight cables under certain conditions as listed below:

- a) The spacecraft cannot provide any performance sensitive cables; these cables must be provided by the instrument/sensor experimenter. **Constraints for their use shall be documented in Figure 10.3-1.**
- b) The spacecraft will only fabricate cables for the flight harness, i.e. cables will not be provided for instrument/sensor level testing.
- c) The instrument/sensor experimenter must provide the connectors used for flight cable fabrication. This procedure will ensure the correct mating connector. Mating connectors are easily procured at the same time that the instrument connector is procured. Three additional sets of connectors, plug, jack, and backshells, shall be provided for harness spares and for the breakout box used to test the harness.

FSCM NO. 88898	SIZE A	DWG. NO. 7345-9016
SCALE	DO NOT SCALE PRINT	SHEET 10-1

Figure 10.3-1 Instrument Supplied Cable Constraints

NOT APPLICABLE

FSCM NO. 88898	SIZE A	DWG. NO. 7345-9016
SCALE	DO NOT SCALE PRINT	SHEET 10-2

10.4

PROCEDURES FOR INTRA INSTRUMENT CABLING REQUESTS

A "Cabling Form" will be developed for each intra instrument flight cable to be fabricated by the spacecraft. This form will be separate from the SIISs, but will be handled by the APL ACE interface manager. This form will have two versions, first a "request" to let the spacecraft know that this cable is to be fabricated by the spacecraft. General information, as available at the time, should be included on this form, and should be submitted as soon as possible. Information to be provided on this "request" should include instrument identification, instrument components involved, cable type, cable length constraints (as available), connector type to be supplied (as available) and any other needed information. This form must then be followed much later by a "fabrication order" which must include the detailed information needed to fabricate the cable. The connectors should accompany this form. It is preferred that this information be in the form of a formal drawing; however, handwritten or hand drawn sketches will be accepted. Whatever form the final drawing takes, it must have the instrument representative's approval signature. **Status of Intra instrument cabling request and form/s is shown in Figure 10.4-1**

After the cable is fabricated, it will be tested for continuity at APL to verify its compliance with the drawing. The drawing and cable will be verified with the instrument team when the instrument is delivered for Observatory integration.

FSCM NO. 88898	SIZE A	DWG. NO. 7345-9016
SCALE	DO NOT SCALE PRINT	SHEET 10-3

Figure 10.4-1 Status of SWIMS Intra Instrument Cabling Request and Form/s

APL will supply the SWIMS /S3DPU interface cable. STATUS: Cable complete and tested.

FSCM NO. 88898	SIZE A	DWG. NO. 7345-9016
SCALE	DO NOT SCALE PRINT	SHEET 10-4

11.0 INSTRUMENT/SENSOR INTEGRATION

11.1 DELIVERY

Each instrument/sensor supplier shall be responsible for the delivery of their instrument/sensor, its ground support equipment (), and the preship review documentation. The instrument/sensors and their associated equipment are delivered to JHU/APL as Government Furnished Equipment (GFE). Calibration of the is the responsibility of the instrument/sensor designer.

At JHU/APL, the instrument/sensor supplier shall be responsible for all testing prior to integration with the ACE Observatory.

JHU/APL will work with the instrument/sensor suppliers to develop integration and test plans. Instrument/Sensor suppliers will be responsible for providing Observatory level test sequences and pass/fail criterion. JHU/APL will use these data to prepare integration test plans and procedures.

11.2 INSTRUMENT/SENSOR RECEIVING/ACCEPTANCE AT JHU/APL

Each instrument/sensor shall be tested on delivery to JHU/APL. The following criteria will be used by JHU/APL for instrument/sensor acceptance.

- a) Prepare JHU/APL receiving flow card (SOR).
- b) Inspection for physical damage; document on flow card.
- c) Inspection for conformance with Interface Control Drawings; document on flow card.
- d) Record data package including handling procedures, test procedures and data; document on flow card.
- e) Instrument/sensor experimenters will perform post-shipment electrical tests to verify survival after shipment and confirm conformance to the performance specifications.
- f) JHU/APL integration and test engineers will review the instrument/sensor supplier's acceptance test data package for comparison with the data from the post-shipment electrical tests.
- g)* JHU/APL PA Manager will review the instrument/sensor documentation to ensure closure of Problem Failure Reports and acceptance test discrepancies. This review is necessary to limit the risk to other flight hardware.
- h) JHU/APL integration and test engineers will review cleanliness documentation and handling procedures.

FSCM NO. 88898	SIZE A	DWG. NO. 7345-9016
SCALE	DO NOT SCALE PRINT	SHEET 11-1

- i)* The experimenter must provide test data or verification that the instrument/sensor will survive the test environments specified in the ACE environmental specification; APL 7345-9007.
- j) Acceptance shall be documented on flow card by the system engineer, integration and test engineer and the PA Manager.

* Data may be supplied at the Pre-Ship Review.

11.3 PRE-INTEGRATION INSTRUMENT/SENSOR INTERFACE TESTING

The purpose of the pre-interface test is to verify that instrument/sensor-to-spacecraft interfaces are within specifications before the instrument/sensor is integrated with the Observatory. Of particular interest are power turn-on transients. The instrument command telemetry interfaces shall be exercised during this test to verify correct performance. These test will be performed prior to integration. Mechanical fit checks will also be performed.

11.4 COMPREHENSIVE PERFORMANCE TEST

The purpose of the comprehensive performance test is to exercise as many instrument operational modes as possible in order to verify the proper performance of the instrument/sensor prior to integration with the Observatory. The integration of the with the instruments and performance verification is the responsibility of the experimenter.

11.4.1 Comprehensive Performance Test Deliverables

The instrument/sensor provider shall provide the following instrument test deliverables prior to integration:

- a) An overall instrument/sensor test plan.
- b) Detailed test procedures.
- c) A document containing specifications, charts, graphs, indicating expected test results. This will be used to compare with the actual test results for performance verification.

These test deliverables are part of the CALTECH IDDPs.

FSCM NO. 88898	SIZE A	DWG. NO. 7345-9016
SCALE	DO NOT SCALE PRINT	SHEET 11-2

APPENDIX A – SWIMS Instrument Mechanical And Electrical Interface Drawings

FSCM NO. 88898	SIZE A	DWG. NO. 7345-9016
SCALE	DO NOT SCALE PRINT	SHEET A1