

# STEREO *IMPACT*

## SEP Sensor Suite Commanding and Users Manual

SEP\_CommandingUserManual\_I.doc  
Version J – 2006 March

---

Andrew Davis

## Document Revision Record

Rev.	Date	Description of Change	Approved By
A	2002-Oct-10	Preliminary Draft	-
B	2002-Oct-30	Incorporate Caltech and GSFC comments	-
C	2003-Jan-24	Update Section 5, ApIDs and Housekeeping	
D	2003-May 1	Update ApIDs – fill packet ApID and expanded SIT ApID range. Update discrete command details. Insert SEP command message and command response formats. Various minor updates to intro and overview sections.	
E	2003-May 5	Incorporate comments from Bob Radocinski and Rick Cook	
F	2003-May 12		
G	2003-June		
H	2005-June	Various updates	
I	2005-July	Updates to binary load and commanding	
J	2006-March	Added SEP and LET list of commands	

## Distribution List

Rick Cook, Caltech SRL  
 Alan Cummings, Caltech SRL  
 Andrew Davis, Caltech SRL  
 Branislav Kecman, Caltech SRL  
 Allan Labrador, Caltech SRL  
 Richard Mewaldt, Caltech SRL  
 Robert Radocinski, Caltech SRL  
 Ed Stone, Caltech SRL  
 Mark Wiedenbeck, Caltech SRL  
 Donald Reames, GSFC  
 Tycho von Roseninge, GSFC  
 Tom Nolan, GSFC  
 Bob Baker, GSFC  
 Kristin Wortman, GSFC  
 Dave Curtis, UCB

## Table of Contents

<b>Document Revision Record</b> .....	<b>i</b>
<b>Distribution List</b> .....	<b>i</b>
<b>1. Introduction</b> .....	<b>1</b>
<b>1.1. Document Conventions</b> .....	<b>1</b>
<b>1.2. Applicable Documents</b> .....	<b>1</b>
<b>1.3. Acronyms</b> .....	<b>2</b>
<b>2. SEP Overview</b> .....	<b>2</b>
<b>2.1. SEP Interfaces to the IMPACT IDPU and the Spacecraft</b> .....	<b>3</b>
<b>3. SEP Instrument Power-on and Boot Procedures</b> .....	<b>3</b>
<b>4. SEP Commanding</b> .....	<b>4</b>
<b>4.1. Discrete Command Messages</b> .....	<b>4</b>
<b>4.2. Data Command Messages</b> .....	<b>5</b>
4.2.1. ASCII Data Command Messages .....	<b>5</b>
4.2.1.1 ASCII Data Command Messages for SEP Central .....	<b>5</b>
4.2.1.2 ASCII Data Command Messages for HET/LET/SIT .....	<b>6</b>
4.2.1.3 General Notes on ASCII Data Command Messages .....	<b>7</b>
4.2.2. Binary Data Command Messages (Table Loads) .....	<b>7</b>
4.2.2.1 Binary Data Command Messages for SEP Central and LET/HET/SIT .	<b>7</b>
<b>4.3. SEP Command Responses</b> .....	<b>9</b>
4.3.1. Format of SEP Command Responses .....	<b>10</b>
<b>4.4. SEP Command List</b> .....	<b>10</b>
<b>5. SEP Telemetry Data</b> .....	<b>13</b>
<b>5.1. SEP Housekeeping Data</b> .....	<b>14</b>
<b>5.2. SEP Beacon Data</b> .....	<b>15</b>
<b>5.3. SEP Science Data</b> .....	<b>16</b>
<b>6. SEP Ground System</b> .....	<b>16</b>
<b>6.1. Commanding of SEP from the IMPACT POCC</b> .....	<b>17</b>
<b>6.2. Commanding of SEP from the SEP GSE</b> .....	<b>18</b>
<b>6.3. Commanding Security</b> .....	<b>18</b>
<b>6.4. SEP GSE Telemetry Socket Server Software</b> .....	<b>19</b>
<b>6.5. Real Time Data Display</b> .....	<b>19</b>
6.5.1. SEP GSE .....	<b>19</b>
6.5.2. Sensor GSEs.....	<b>19</b>
<b>6.6. Non-Real time Data Analysis</b> .....	<b>19</b>
<b>6.7. Data Logging</b> .....	<b>19</b>
6.7.1. SEP GSE .....	<b>19</b>
6.7.2. Sensor GSEs.....	<b>20</b>
<b>7. SEP GSE User Manual</b> .....	<b>20</b>
<b>8. Other Services Provided to SEP by the Spacecraft</b> .....	<b>20</b>
<b>9. SEP Constraints</b> .....	<b>Error! Bookmark not defined.</b>

## 1. Introduction

The IMPACT SEP sensor suite consists of four sensors – LET, HET, SEPT and SIT. Four microprocessors are dedicated to controlling, interfacing, and acquiring data from these sensors. This document describes how to run the SEP sensor suite after delivery to APL and during the mission, referring to other documents as necessary. This document also defines SEP commands, command formats, command response formats, and SEP operational constraints.

### 1.1. Document Conventions

In this document, **TBD** (To Be Determined) means that no information currently exists. **TBR** (To Be Resolved) means that a statement is preliminary. In either case, the initials of the institutions/persons responsible for providing the information typically follow the acronym.

### 1.2. Applicable Documents

The following documents are closely interrelated with this specification. All documents can be found on either the Berkeley STEREO/IMPACT FTP site, or the Caltech STEREO/SEP ftp site:

<http://sprg.ssl.berkeley.edu/impact/dwc/>

<ftp://mussel.srl.caltech.edu/pub/stereo/docs>

1. STEREO-CIT-001, STEREO-CIT-002 - LET and SEP Central Software Development Plan and Software Requirements docs.
2. HET Software Development Plan and Software Requirements docs.
3. SIT Software Development Plan and Software Requirements docs.
4. SEPT Operation Control and Data Processing Requirements.
5. STEREO-CIT-012 - SEP GSE Software Development Plan.
6. STEREO-CIT-005 - P24 MISC processor manual
7. IMPACT Intra-Instrument Interface ICD
8. STEREO-CIT-009 - LET-SEP\_Central ICD
9. STEREO-CIT-008 - HET-SEP\_Central ICD
10. STEREO-CIT-010 - SEPT-SEP\_Central ICD
11. STEREO-CIT-011 - SIT-SEP\_Central ICD
12. STEREO-CIT-001 - P24 MISC G-buss I/O Interface Document (**TBD-Caltech-WRC**)
13. STEREO-CIT-003 - LET, HET and SIT Science Data Frame Format Specifications
14. SEPT FPGA Data Sheet
15. IMPACT/Spacecraft ICD
16. ICD/MOC-POC\_ICD (MOC to POCC ICD)
17. ICD/IMPACT\_CTM\_B (IMPACT Command & Telemetry database)
18. TBD (POCC Users Manual)
19. Specifications/CmdFmt – IMPACT IDPU Command Formats.
20. STEREO-CIT-016 - SEP Housekeeping packet format Spec.

### 1.3. Acronyms

ACE	Advanced Composition Explorer
API	Application Programming Interface
ApID	Application Process Identifier
ASCII	
CCSDS	Consultative Committee for Space Data Systems
CR	Carriage-Return character (0x0D)
CRLF	Two characters – CR and LF
EEPROM	Electrically Erasable Programmable Read Only Memory
FPGA	Field Programmable Gate Array
GSE	Ground Support Equipment
HET	High Energy Telescope
ICD	Interface Control Document
IMPACT	In situ Measurements of Particles and CME Transients
LET	Low Energy Telescope
LF	Line-feed character (0x0A)
MISC	Minimal Instruction Set Computer
MOC	Mission Operations Center
POCC	Payload Operations Control Center
RAM	Random Access Memory
SCM	Supplemented Command Message
SEP	Solar Energetic Particles
SIT	Suprathermal Ion Telescope
SEPT	Solar Electron Proton Telescope
SEPT-NS	SEPT-North-South electronic unit
SEPT-E	SEPT-Ecliptic electronic unit
SRAM	Static Random Access Memory
SRL	Space Radiation Laboratory
SSD	Solid State Detector

## 2. SEP Overview

The Solar Energetic Particles (SEP) sensor suite for IMPACT/STEREO consists of the Solar Electron Proton Telescope (SEPT), the Suprathermal Ion Telescope (SIT), the Low Energy Telescope (LET), and the High Energy Telescope (HET). SEPT consists of two units on each spacecraft, SEPT-NS and SEPT-E. The SEP suite is designed to measure the intensities of energetic particles from solar flares and from Coronal Mass Ejection (CME) driven shocks over a wide range of energies, intensities and particle types.

The LET, HET, and SIT sensors each require a dedicated microprocessor for onboard data processing and sensor control. An additional microprocessor, called SEP Central, gathers data from all the SEP sensors, gathers SEP housekeeping data, controls the SEP SSD Bias power supply, manages the SEP interface to the IMPACT IDPU, and manages the interfaces to the sensors. The SEPT-NS and SEPT-E units do not require dedicated microprocessors and are controlled directly by SEP Central.

The microprocessor used in LET and SEP Central is the P24 MISC (Minimal Instruction Set Computer). The P24 MISC, developed at Caltech, has a 24-bit CPU core with dual stack architecture intended to efficiently execute Forth-like instructions. The processor design is simple to allow implementation within field programmable gate arrays

(FPGAs). The microprocessor used in HET and SIT is called the CPU24. It is based closely on the design of the P24 MISC, implemented with some modifications at GSFC to tailor the processor to their application. Both the MISC and the CPU24 are implemented in the ACTEL 54SX72A FPGA.

There are two serial interfaces between the SEP sensors and the SEP Central MISC. The first interface is bi-directional, for transferring boot-code, commands, and command responses. The second interface is uni-directional, for transferring data from the instruments to the SEP Central MISC. The protocol for using these interfaces is defined in References 8-11. Details of memory, I/O, operating system, and other interfaces can be found in References 6 and 8-11.

Processed data from the microprocessors associated with LET, HET, and SIT are gathered by the SEP Central MISC as described in references 8, 9, and 11, and formatted for transmission to the IMPACT DPU as described in Reference 7. Data from SEPT-NS and SEPT-E are gathered directly by the SEP Central MISC as described in references 4 and 10. Onboard processing of SEPT data occurs in the SEP Central MISC, as described in references 1 and 4, before the data are formatted and transmitted to the IMPACT DPU. Figure 2.1 shows a block diagram of the SEP Sensor Suite.

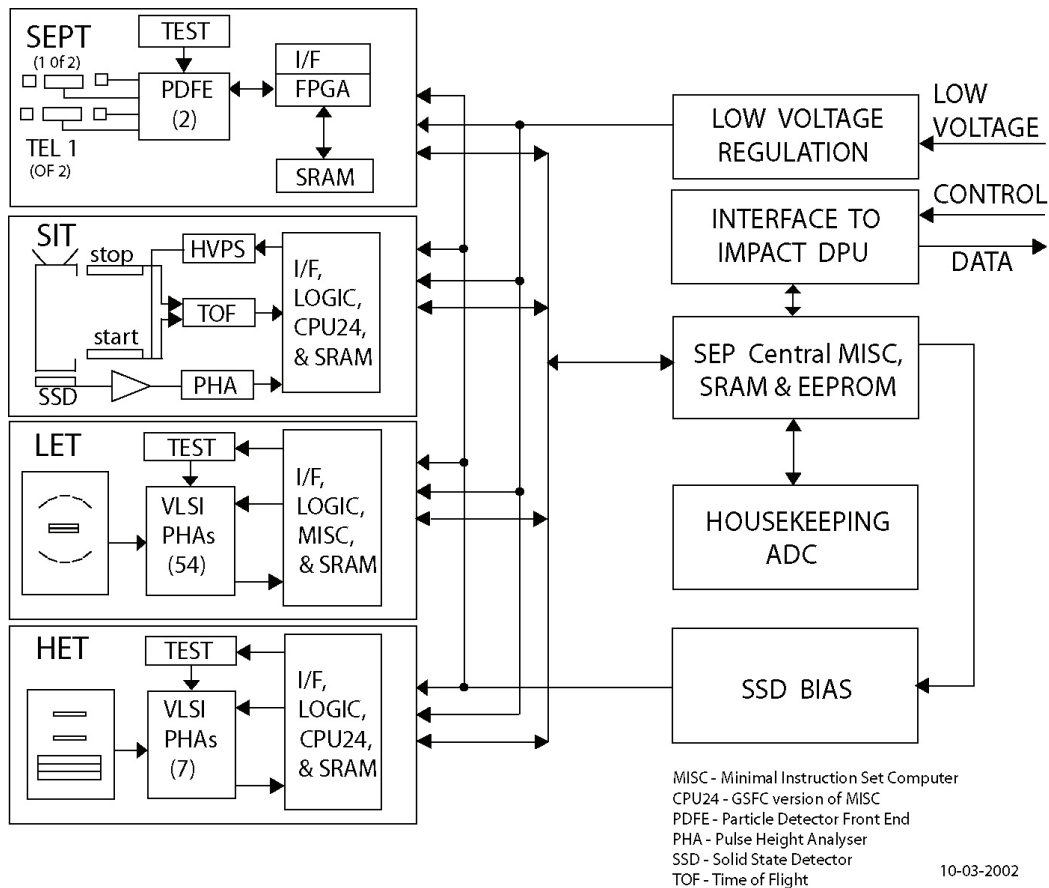

Figure 2.1: SEP Sensor Suite Block Diagram

The SEP instruments are mounted at various locations on the spacecraft body consistent with their Field-of-View requirements, as shown in figure 2.2.

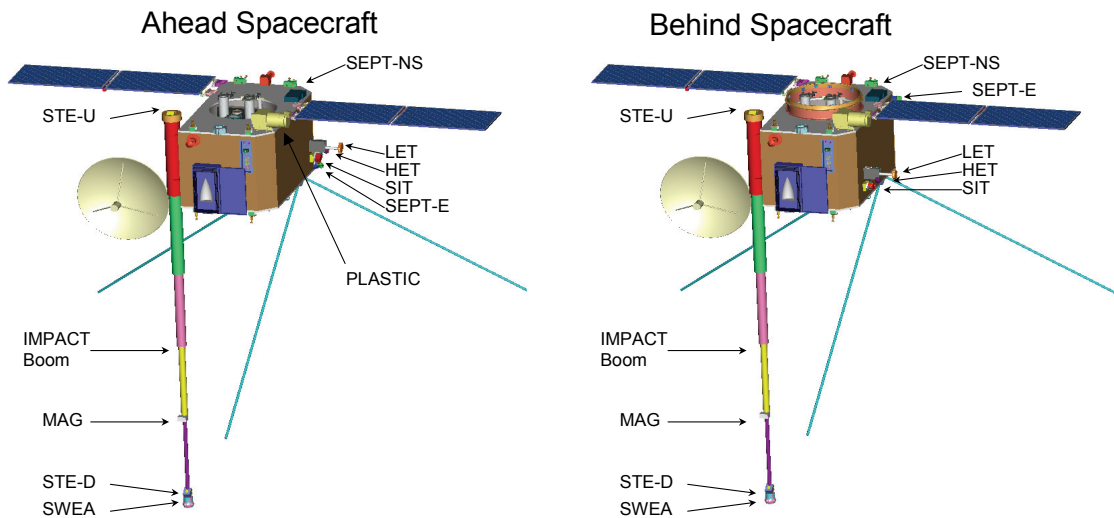

Figure 2.2: IMPACT locations on STEREO

### 2.1. SEP Interfaces to the IMPACT IDPU and the Spacecraft

The IMPACT IDPU provides the interface between the STEREO Spacecraft C&DH system and the IMPACT and PLASTIC Instruments, including SEP. All information transfer between the IMPACT/PLASTIC instruments and the Spacecraft/Ground flows through the IDPU, including telemetry, commands, and status. SEP communicates with the IDPU over a dedicated serial interface, as described in reference 7. The SEP sensors and SEP Central are designed to be relatively autonomous. Once their look-up tables have been loaded and their modes and parameters set, they will cycle through their data collection automatically, and provide data to the IDPU without handshaking.

## 3. SEP Instrument Power-on and Boot Procedures

The LET, HET, and SIT processors will power-on whenever SEP Central powers-on. After power-on, the LET, HET, and SIT processors will execute a small boot loader program stored in the processor FPGA. This boot loader will manage the reception and execution of boot code received from SEP Central on the serial command link. After SEP Central boots, the process of booting LET, HET, and SIT begins via a command from the GSE. After the sensor boot command is received, SEP Central begins the process of transferring boot code from SEP EEPROM to the LET, HET, and SIT processors over the serial command link.

After power-on, SEP Central attempts to boot from page 0 of EEPROM. Subsequently, three different discrete reset commands can be sent to SEP. The first causes SEP Central to boot from page 0 or EEPROM. The second causes SEP Central to boot from page 1 of

EEPROM, and the third causes SEP Central to accept boot code over the serial link to the IDPU.

## 4. SEP Commanding

Prior to delivery of the SEP suite to APL, SEP command messages may originate at the IMPACT Payload Operations Control Center (POCC), the SEP GSE, or at the sensor GSEs (see section 5, below). After APL delivery, command messages destined for the SEP suite will enter into the STEREO command stream only at the IMPACT Payload Operations Control Center (POCC). The SEP team will control the SEP suite by instructing the IMPACT POCC to upload stored commands. In any case, at the point where they originate, SEP command messages are contained in CCSDS telecommand packets, which are themselves contained in Supplemented Command Messages (SCMs), as described in reference 16. During the mission, commands are sent by the IMPACT POCC to the Mission Operations Center (MOC), then on to the spacecraft, then to the IMPACT IDPU, and finally to SEP Central. Formulation of SEP commands on the ground is described in section 5 of this document.

The spacecraft forwards CCSDS telecommand packets (contained with the SCMs) within the IMPACT or PLASTIC ApID range (Application Identifier, a code in the CCSDS packet header) to the IMPACT IDPU (see reference 15 and 16). The allocation of ApIDs to SEP is defined in reference 19. The IMPACT IDPU forwards the Application Data Field of telecommand packets with ApIDs within the SEP ApID range to SEP Central (i.e. the IMPACT IDPU strips off the CCSDS packet headers). SEP Central receives command messages from the IMPACT IDPU as a series of 24-bit command words as described in reference 7.

The SEP team has requested, and the Berkeley/IMPACT team has agreed, that there will be a delay of at least 3.5 ms between each 24-bit command word sent from the IMPACT IDPU to SEP Central.

**The SEP team imposes a requirement upon itself that the Application Data Field of SEP telecommand packets shall contain an even number of bytes.** However, if the IMPACT IDPU detects a SEP telecommand packet with an odd number of bytes in the application data field, it will pad the number of bytes out to an even number before forwarding to SEP Central. The pad byte used by the IDPU is currently the space character (0x20).

SEP Central routes command messages to the appropriate SEP sensors based on routing information contained in the messages, as described below.

### 4.1. Discrete Command Messages

Discrete commands are recognized by hardwired logic in SEP Central. Discrete commands are also executed by the hardwired logic.

CCSDS telecommand packets containing discrete command messages for SEP will use ApID 0x26F. When the IMPACT IDPU receives a telecommand packet with ApID 0x26F, it will generate exactly one 24-bit command word with address=0xFF and containing the first 16 bits of the application data field of the telecommand packet, and



one 24-bit command word with an address of 0x01 for each subsequent 16-bit data group in the telecommand packet. (see sections 7.3 and 7.4 of reference 7).

The discrete command code is contained in the first 16 bits of the application data field of the telecommand packet. The only discrete commands currently envisioned for SEP Central is are the Reset commands described above.

## **4.2. Data Command Messages**

CCSDS telecommand packets containing Data Command Messages for SEP will use ApIDs in the range 0x260 - 0x26E, inclusive. When the IMPACT IDPU receives a telecommand packet within this range, it passes the data in the application data field of the packet to SEP Central, as described in section 7.4 of reference 7.

Data command messages are passed on by the SEP Central hardware to software running in the SEP Central MISC for routing/execution.

Data command messages that are destined for SEPT-NS, SEPT-E, or SEP Central are executed directly by SEP Central. Data command messages destined for HET, LET, or SIT are routed by SEP Central to those sensors as described below.

Two classes of Data Command Messages are defined for SEP: ASCII and Binary.

### **4.2.1. ASCII Data Command Messages**

These are generally used to change the mode of operation of SEP Central, or one of the sensors.

We define here an **ASCII Command** to be a series of N printable characters, with the Nth character being CR (ASCII char 0x0D), followed optionally by a series of M “delay” characters (ASCII char 0x00).

An ASCII command may NOT contain the command message termination character 0x03, which is interpreted by SEP Central to be the termination of a command message for HET/LET/SIT (see section 4.2.1.2 below).

ASCII commands are used to build ASCII Data Command Messages, as described below. The function of the “delay” characters in ASCII commands is also described below.

#### **4.2.1.1 ASCII Data Command Messages for SEP Central**

ASCII data command messages destined for SEP Central consist of a series of ASCII Commands.

The “delay” characters are not necessary for ASCII data command messages destined for SEP Central (i.e. M=0).

The shortest ASCII command that can be sent to SEP Central (N=1 and M=0) is simply the CR character (ASCII char 0x0D). This will elicit a response from SEP Central consisting of CRLF (ASCII chars 0x0D and 0x0A) followed by an ASCII "prompt" string. See section 4.3 (Command Responses) below for prompt string definitions for SEP Central, HET, LET, and SIT.

More than one ASCII command for SEP Central may be packed into a telecommand packet. ASCII commands for SEP Central may span telecommand packets, but this is not recommended. See section 4.2.1.3.

Note again that SEP Central executes commands that affect SEPT-NS and/or SEPT-E.

#### 4.2.1.2 ASCII Data Command Messages for HET/LET/SIT

If a command message is destined for HET, LET, or SIT, then SEP Central initializes the multiplexed serial command link to the appropriate sensor based on a routing command contained in the command message, and forwards the command to the appropriate sensor.

ASCII data command messages for LET/HET/SIT consist of ASCII Commands (defined in section 4.2.1 above) preceded by a routing command, and followed by the command message termination character 0x03. Note that the routing command is itself an ASCII command that is executed by SEP-Central. Neither the routing command nor the command message termination character is passed on to the sensors. The message format is summarized in Table 4.1 below:

Table 4.1 ASCII Data Command Message for HET/LET/SIT		
Item	Length (bytes)	Description
"XXX-CMD"	7	Routing command string. XXX = HET, LET, or SIT. → ASCII
0x0D	1	CR. This terminates the routing command that is interpreted by SEP-Central. Routing Cmd
ASCII Commands	X	A series of ASCII commands, as defined in section 4.2.1
0x03	1	Command message termination character (not passed on)
<b>9+X</b>		<b>Total Length of ASCII Command Message</b>

As mentioned before, an ASCII command may NOT contain the command message termination character 0x03, which is interpreted by SEP Central to be the termination of a command message for HET/LET/SIT.

In ASCII commands destined for HET/LET/SIT, the function of the optional delay characters (0x00) following the CR character is to introduce time delays between ASCII commands transmitted by SEP Central to the sensor, and also a delay before SEP Central receives the command message termination character. Each pair of delay characters adds a 3.5 ms delay (due to the delay inserted by the IMPACT IDPU – see section 4.0). **Delay characters in ASCII commands are absorbed by SEP Central and are not passed on to the sensors.**

As part of execution of the routing command, SEP Central will send a short ASCII command (consisting of the CR character) to the appropriate sensor. This will elicit a response from the sensor consisting of CRLF (ASCII chars 0x0D and 0x0A) followed by an ASCII "prompt" string. See section 4.3 (Command Responses) below for prompt string definitions for SEP Central, HET, LET, and SIT.

As an example, the sequence of events that occurs when an ASCII data command message for LET is transmitted to SEP Central by the IMPACT IDPU is outlined below. The sequence is the same for HET and SIT.

1. SEP Central encounters the LET-CMD routing command, indicating the beginning of an ASCII command message for LET.
2. SEP Central initializes the serial command link with LET.
3. SEP Central sends a short ASCII command to LET, consisting of the CR character. This elicits a short response from LET - the LET prompt – see section 4.3 below.
4. SEP Central routes subsequent characters it receives to LET, except for delay characters.
5. While SEP is receiving delay characters from the IDPU, LET has extra time to execute commands it has received, and to transmit command response characters.
6. SEP Central encounters the command message termination character 0x03, and terminates the LET commanding mode initiated in step 2. **Any command response characters transmitted by LET after this step will be lost.**

After receipt of the command message termination character, SEP Central interprets all subsequent command characters until another routing command is received.

#### **4.2.1.3 General Notes on ASCII Data Command Messages**

The length of ASCII commands should be an even number, up to and including the CR. It is recommended that the space character (0x20) be used before the CR character to pad the length out to an even number of bytes, including the CR character.

The length of an ASCII command message is limited only by the limits on the length of SCMs. However, it is recommended that the length be limited so that the command message fits within a single CCSDS telecommand packet (max 1076 bytes of data)

Byte order shown in the format is as the packet is created in the originating GSE. We must work to understand and deal with any en-route byte swapping.

No checksum is provided in the ASCII data command message format.

#### **4.2.2. Binary Data Command Messages (Table Loads)**

These are generally used to update a region of RAM in SEP Central or one of the sensors.

##### **4.2.2.1 Binary Data Command Messages for SEP Central and LET/HET/SIT**

A Binary data command message consists of a routing command, a 16-bit byte count (N), N-2 bytes of binary data, a 2-byte checksum, an optional series of delay characters (0x00), and a command message termination character (0x03). The message format is summarized in Table 4.2 below:

<b>Table 4.2 Binary Data Command Message</b>		
<b>Item</b>	<b>Length (bytes)</b>	<b>Description</b>
ASCII Routing Command	M	An ASCII Command used by SEP-Central to route the message.
Byte cnt 0 (MSB)	1	A 16-bit Count of bytes that follow, including the checksum (N)
Byte cnt 1 (LSB)	1	
Binary data	N-2	N-2 bytes of binary data
Chksum byte 0 (MSB)	1	A 16-bit value, which, when added to the N-2 bytes of binary data, makes the 16-bit sum = 0
Chksum byte 1 (LSB)	1	
Delay chars	X	An optional series of delay characters (0x00), which will be absorbed by SEP Central, and not passed on.
0x03	1	Command message termination character (not passed on)
<b>M+N+X+3 Total Length of Binary Command Message</b>		

The routing command is an ASCII command of **even length** with no delay characters that is interpreted by SEP-Central. The following routing command strings are defined, although others may be added to the list:

- HET-BIN                      Binary data for HET
- HET-BINC                    Compressed binary data for HET
- SIT-BIN                      Binary Data for SIT
- SIT-BINC                    Compressed binary data for SIT
- LET-BIN                     Binary data for LET
- SEP-BIN                     Binary data for SEP Central

In binary command messages destined for HET/LET/SIT, the function of the optional delay characters (0x00) following the CR character is to introduce a time delay before SEP Central receives the command message termination character. Each pair of delay characters adds a 3.5 ms delay (due to the delay inserted by the IMPACT IDPU – see section 4.0). As in ASCII command messages, these delays allow the sensor extra time to process the message and generate a response before SEP Central receives the command message termination character.

**SEP Central does not absorb delay characters that may appear in the byte count, the binary data, or the checksum.** These parts of the message are passed on unmodified by SEP Central.

The length of a Binary command message is limited by the 16 bits allocated to the byte count. However, it is recommended that the length be limited so that the message fits within a single CCSDS telecommand packet (max 1076 bytes of data)

The Byte order shown in the format is as the packet is created in the originating GSE We must work to understand and deal with any en-route byte swapping that might occur.

As an example, the sequence of events that occurs when a binary data command message for HET is sent to SEP Central is outlined below. The sequence is the same for SIT. There are currently no binary commands defined for LET.

1. SEP Central encounters the HET-BIN routing command, indicating the beginning of a command message for HET
2. SEP Central initializes the serial command link with HET
3. SEP Central sends a short ASCII command to HET, consisting of the CR character. This elicits a short response from HET - the HET prompt – see section 4.3 below.
4. SEP Central sends an ASCII command (“binary” CR) to HET to put HET in the correct mode for receiving binary data.
5. SEP Central reads the 16-bit byte count in the binary command message.
6. SEP Central routes the byte count and the next N characters it receives from the IDPU to LET.
7. SEP Central maintains the serial command link with HET, in order to receive any responses from HET, until it receives the command message termination character 0x03. As in the ASCII command message, delay characters can be inserted into the message before the command message termination character to allow time for HET to transmit a response.

### 4.3. SEP Command Responses

SEP Central buffers all command responses and transmits them to the IDPU in SEP command response CCSDS telemetry packets. SEP command response CCSDS telemetry packets are assigned a unique ApID from the SEP ApID range (see section 5 below). The body of these command response packets is a container for raw command responses from the SEP sensors and SEP Central.

Command responses from the SEP sensors and SEP Central should generally be in human-readable ASCII format. This will ensure that the contents of SEP command response packets can be easily scanned by personnel on the ground, and easily incorporated into command response logs.

Although command response messages do not count towards the SEP telemetry allocation, Section 8 of the IMPACT Intra-instrument Interface ICD (reference 7) specifies that SEP may not exceed its telemetry allocation by more than two CCSDS packets over any 1-minute interval. Therefore SEP Central must ensure that no more than two command response packets are transmitted to the IDPU each minute. SEP Central achieves this by buffering command responses into a software FIFO. Software running in SEP Central inspects this buffer at regular intervals and constructs command response packets from the contents at a rate of no more than two packets per minute. Thus, more than one command response may be packed into the same command response packet. The software attempts to minimize latency for short command responses, while the command response FIFO is sized to accommodate the largest command response generated by the SEP sensors.

**Update to the above:** if during a given minute, one or more of the SEP sensors generates fewer science packets than the maximum number of science packets allocated to it, SEP

Central may fill the unused slots with command response packets, if any are available to be sent.

SEP Central transmits command response packets to the IMPACT IDPU per the protocols in reference 7.

#### 4.3.1. Format of SEP Command Responses

In order that the SEP command response log be readable and easily deciphered, SEP Central and HET/LET/SIT must adhere to some rules for command responses:

- The response to the simplest ASCII command (CR) shall be the following:
  - HET: CRLF, followed by the prompt string "HET> "
  - LET: CRLF, followed by the prompt string "LET> "
  - SIT: CRLF, followed by the prompt string "SIT> "
  - SEP Central: CRLF, followed by the prompt string "SEP> "
- In each case above, the ">" character in the prompt string is followed by a space character.
- The response to other ASCII commands shall be an ASCII response string, followed by the response to the "CR" command, as defined above. The ASCII response string will generally echo the command, but it may also contain other information.

#### 4.4. SEP Command List

Here we define all SEP and LET commands and their parameters that are used in standard procedures. Other commands are possible, but would first need to be qualified on an EM unit. HET and SIT commands are described elsewhere.

##### SEP Central Commands

ALLON1

Boot LET, HET and SIT and initiate normal operations of SEPT for flight unit 1

ALLON2

Boot LET, HET and SIT and initiate normal operations of SEPT for flight unit 2

14000 HET-BOOT	Boot HET
21000 SIT-BOOT	Boot SIT
47000 LET-BOOT	Boot LET

INITPCHK	Initialize checksums for eeprom
INITRCHK	Initialize checksums for ram

PCHKS.	Echo eeprom checksums
RCHKS.	Echo ram checksums

PROMOK ?

Echo value of PROMOK variable:

-1 => no change in checksum since most recent INITRCHK.

0 => a change in checksum since most recent INITRCHK

CODEOK ?

Echo value of CODEOK variable:

-1 => no change in checksum since most recent INITRCHK

0 => a change in checksum since most recent INITRCHK

SEP-BIN

Initiates binary upload to SEP Central (for detailed format info see above ...)

HET-BIN

Initiates binary upload to HET

SIT-BIN

Initiates binary upload to SIT

xxx HET>PROM

Writes into HET image block xxx in eeprom following SEP-BIN, only if SEP-BIN checksum ok.

xxx SIT>PROM

Writes into SIT image block xxx in eeprom following SEP-BIN, only if SEP-BIN checksum ok.

xxx LET>PROM

Writes into SIT image block xxx in eeprom following SEP-BIN, only if SEP-BIN checksum ok.

PHVON

Turns on the positive detector bias voltages

NHVON

Turns on the negative detector bias voltages

PHVOFF

Turns off the positive detector bias voltages

NHVOFF

Turns off the negative detector bias voltages

BANKCP

Copies from eeprom bank 0 to bank 1.

## LET Commands

### ADCMODE

Disables "live stim" events, in favor of "adc stim" events only. Allows for faster collection of a complete ADC calibration data set.

### THRMODE

Similar to ADCMODE, but the range of calibration DAC is reduced to focus on the threshold regions.

### NORMAL

Undoes ADCMODE or THRMODE to place instrument back into normal operation, in which both "live stim" and "adc stim" events are produced at a rate near 3 per second.

### QUIET

Disables both live stim and adc stim events.

### HERE .

Verifies the address at the end of FORTH dictionary in LET memory

### TIME.

Displays elapsed time in hr/min/sec/sub-sec since the last LET boot

### 30 TEMPGOAL !

Raises LET op-heater set point to +45 C (facilitates verification of functionality at room temperature and in hot T/V soak)

### 230 TEMPGOAL !

Lowers set point to -40 C (facilitates verification of functionality in cold T/V soak)

157 TEMPGOAL ! to return set point to -10 C (flight default)

### 50000 STIMPER!

Raises LET stim pulser rate to 4 per second

### 100000 STIMPER!

Returns LET stim pulser rate to 2 per second (flight default)

### 0 FCULL !

Turns off culling of cross-talk hits in telemetered events

### -1 FCULL !

Turns on culling of cross-talk hits in telemetered events (flight default)

### HGT.

Prints out high-gain thresh settings of 54 channels in 64-ch array



374 32 HGTHRS!

Varies high-gain threshold on L1B0a channel (ch #32 in the array)

INITCHKs

Re-initializes LET checksums

(These are the only LET commands used routinely. Significant other commanding capability exists for handling non-routine conditions. Specific command sequences to address non-routine situations will be defined and tested on the LET EM unit prior to execution on any flight unit.)

## 5. SEP Telemetry Data

Telemetry data generated by the SEP sensor suite falls into five categories: science data, housekeeping data, beacon data, fill data, and command responses. Command responses are described in section 4.3 above.

Except for beacon data, SEP telemetry data are transferred to the IMPACT IDPU as CCSDS telemetry packets. The packet ApID code defines the origin and content of these packets. ApID codes are allocated to SEP as follows (all numbers are decimal, and all ranges are inclusive):

- Command Response 576
- SEP Combined Housekeeping 577
- LET science 580 – 587
- LET housekeeping 588
- LET beacon 589
- HET science 590 – 597
- HET housekeeping 598
- HET beacon 599
- SIT science 605 – 617
- SIT housekeeping 618
- SIT beacon 619
- SEPT science 600, 601
- Fill Packet 623
- Spares 578 – 579, 602 – 606, and 620 - 622

SEP sensors are free to define several different science packet types if they wish, using their allocated science ApID codes.

Except for command responses, LET, HET and SIT generate data in 272-byte CCSDS telemetry packets formatted as described in reference 16. SEP Central acquires packets from these sensors via the uni-directional serial data link. The protocols for data transfer are the same for LET, HET and SIT. These protocols are described in detail in references 8 - 11.

**Each sensor shall set the checksum byte in every packet transmitted, according to the protocol described in references 8-11.**

The only parts of any packet from LET/HET/SIT that are modified by SEP Central are:

- The UT time-stamp in the header
- The four least-significant bits of the sub-seconds field of the timestamp in the packet secondary header (used as packet diagnostic flags by SEP Central).
- The packet checksum byte (recalculated after the above two modifications are made)

Otherwise the packets are just passed on by SEP Central to the IMPACT IDPU.

Within a given minute interval:

- HET sends data packets during a 200 ms interval immediately following second ticks 0, 3, ..., 57
- SIT sends data packets during a 200 ms interval immediately following second ticks 1, 4, ..., 58
- LET sends data packets during a 200 ms interval immediately following second ticks 2, 5, ..., 59

LET, HET, and SIT must send at least one packet during each window (for diagnostic testing purposes). More than one packet may be sent in the same window, but packets should be spread out roughly evenly over the 60-second cycle. Since LET, HET, and SIT are each allocated 20 windows per minute (more than they need, and more than their telemetry allocation), some packets will be fill-packets (ApID = 623). SEP Central does not forward fill-packets to the IMPACT IDPU.

Since SEPT does not have its own processor, the data transfer protocol is different for SEPT. Data acquisition from the two SEPT telescopes (electronic units) is managed directly by SEP Central, per reference 4, and SEP Central builds SEPT science data packets.

In general, data packets collected from the sensors during minute (N+1) by SEP Central contain data collected during the prior minute (N) and are transmitted to the IMPACT DPU during minute (N+2). SEP Central fills in the UT portion of all packets received during minute (N) with the UT code associated with tic0 of minute (N-1). (i.e. the UT code of a packet will refer to the beginning of the minute during which it's data was accumulated.)

SEP Central transmits telemetry packets to the IMPACT IDPU per the protocols in reference 7.

### **5.1. SEP Housekeeping Data**

The SEP telemetry allocation for housekeeping data is 260 bytes/minute (the application data field of one 272-byte CCSDS telemetry packet, minus the checksum byte).

- HET: 41 bytes/min
- LET: 102 bytes/min
- SEPT: 26 bytes/min

- SIT: 36 bytes/min
- SEP Central: 55 bytes/min

The contents of the SEP housekeeping are defined in reference 20.

During minute N+1, HET, LET and SIT will each send a packet of housekeeping data collected during minute N to SEP Central. HET, LET and SIT will format housekeeping data into CCSDS packets, using one of their allocated ApIDs to identify the packet (see section 5.0). Each sensor will send one housekeeping packet once per minute.

**HET, LET, and SIT will send their housekeeping data packets to SEP Central during the first window available to them each minute. Thus, HET will always send its HK packet during tick 0, and SIT will always send its HK packet during tick 1, and LET will always send its HK packet during tick 2. This allows for simplification of software in SEP Central.**

Housekeeping data from HET, LET, and SIT should be positioned at the beginning of the housekeeping packets sent by those sensors to SEP Central.

During minute N+1, SEP-Central will receive HK CCSDS packets from the HET, LET and SIT sensors. At the beginning of N+2, SEP-Central will combine HK packets from HET, LET and SIT with HK data gathered from SEPT and from the SEP common electronics (all of the data having been collected during minute N on each sensor) into a common SEP HK CCSDS packet. The format of this packet is described in reference 20.

SEP-Central will send the common SEP HK packet to the IDPU during minute N+2, per the protocols in reference 7.

## **5.2. SEP Beacon Data**

The SEP telemetry allocation for beacon data is 144 bytes/minute

- HET: 28 bytes/min
- LET: 46 bytes/min
- SEPT: 44 bytes/min
- SIT: 24 bytes/min
- STATUS: 2 bytes/min

During minute N+1, HET, LET and SIT will each send a packet of beacon data collected during minute N to SEP Central. HET, LET and SIT will format Beacon data into 272-byte CCSDS packets, using one of their allocated ApIDs to identify the packet (see section 5.0). Each sensor will send one housekeeping packet once per minute.

**HET, LET, and SIT will send their Beacon data packets to SEP Central during the second window available to them each minute. Thus, HET will always send its Beacon packet during tick 1, and SIT will always send its Beacon packet during tick 2, and LET will always send its Beacon packet during tick3. This allows for simplification of software in SEP Central.**

Beacon data from HET, LET, and SIT should be positioned at the beginning of the beacon packets sent by those sensors to SEP Central.

At the beginning of N+2, SEP-Central will combine Beacon packets from HET, LET and SIT with Beacon data gathered from SEPT (all of the data having been collected during minute N on each sensor) into a SEP Beacon message block. The format of this message block is described in Section 8 of the IMPACT Serial Interface Doc. It is not a CCSDS packet. Referring to that document, we find:

SEP Beacon message:  
 Message type = 2  
 Message length = (144bytes/2 +1) - 2 = 71  
 → MESSAGE\_ID word = 0x0847

SEP-Central will send the Beacon message to the IDPU during minute N+2, in the interval between 0 and 6 seconds after the 1-minute sample tic.

The contents of the SEP housekeeping are defined in reference 20.

### 5.3. SEP Science Data

The SEP telemetry allocation for science data is as follows:

- HET: 6      272-byte telemetry packets/min
- LET: 16     272-byte telemetry packets /min
- SEPT: 2     272-byte telemetry packets/min
- SIT: 12     272-byte telemetry packets/min

The contents of the SEP housekeeping are defined in reference 20.

During minute N+1, HET, LET and SIT will each send packets of science data collected during minute N to SEP Central. HET, LET and SIT will format science data into 272-byte CCSDS packets, using one of their allocated science ApIDs to identify the packet (see section 5.0).

**During each minute, the sensors shall transmit their science data packets to SEP Central AFTER they have transmitted their Housekeeping and Beacon packets.**

Each sensor may send up to its allocation of science packets each minute. If there was not enough science data collected by a sensor during a given minute to fill the science allocation, the sensor may substitute fill-packets (ApID 623) for science packets. SEP Central does not pass on fill-packets to the IDPU.

## 6. SEP Ground System

The MOC controls the STEREO spacecraft. The IMPACT POCC at Berkeley controls the IMPACT suite. The IMPACT POCC communicates with the MOC over the Internet using Secure Shell (SSH) and other security measures. The POCC to MOC interface is described in reference 16. The operation of the IMPACT POCC is described in reference 18.

The SEP GSE communicates with the IMPACT POCC over the Internet using Secure Shell (SSH) and other security measures. The SEP GSE to IMPACT POCC interface is described in references 16 and 18. Figure 3.1 shows a block diagram of the interfaces between the SEP sensor GSEs, the SEP GSE, the IMPACT POCC (IMPACT GSE), the

IMPACT IDPU onboard the spacecraft, and the SEP sensor suite. For simplicity, MOC and spacecraft interfaces are not shown. Commanding capabilities that are disabled after delivery of the SEP suite to APL are marked with a red X.

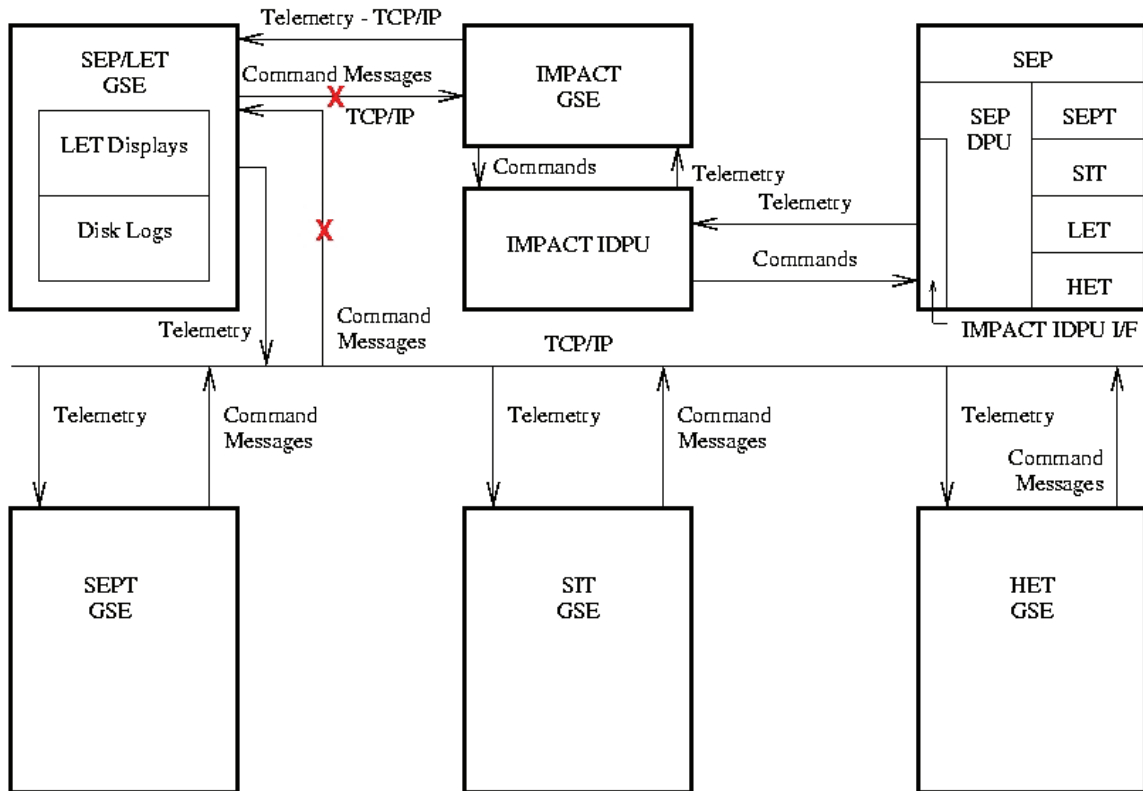

Figure 3.1: IMPACT locations on STEREO

The SEP GSE performs the following functions:

- Commanding of the SEP sensor suite (prior to delivery of the SEP suite to APL), via the IMPACT-POCC interface
- Telemetry Socket Server, providing SEP telemetry to other networked clients (SEP sensor GSEs)
- Display of SEP housekeeping and status data
  - Real time
  - Non-real time
- Logging of SEP data to disk

### 6.1. Commanding of SEP from the IMPACT POCC

Commands destined for the SEP sensor suite may originate either at the IMPACT POCC or at the SEP GSE, or at the SEP sensor GSEs. After delivery of SEP to APL, all SEP commands will originate at the IMPACT POCC.

Pre-coded commands in the CCSDS telecommand format can be referenced by file name by the IMPACT POCC. This scheme is the method that will be used by the SEP team to command the SEP sensor suite after delivery of the SEP sensor suite to APL, and during the mission.

## 6.2. Commanding of SEP from the SEP GSE

This section describes capabilities that will only be enabled prior to the delivery of the SEP sensor suite to APL.

All commands forwarded by the SEP GSE to the IMPACT POCC are in the form of CCSDS telecommand messages as described in reference 16.

The SEP GSE software provides support for commanding from the SEP GSE keyboard using a terminal-like program.

- The program allows the user to type any command on the SEP GSE keyboard. On <CR>, the command is sent.
- Monitors and displays any command responses. Allows the user to send any stored command message on the SEP GSE using a simple keyboard command.
- If command forwarding is enabled, and any remotely sent command message arrives while the terminal program is running, the program will allow the user to either reject the command message or allow it to be sent.

The SEP GSE software provides support for sending command messages stored on its disk to SEP.

- The programs are stored in a variant of the standard CCSDS command messages that use relative times instead of absolute times.
- If the command message is to be forwarded to the IMPACT GSE, the SEP GSE will convert the stored command message into a standard command message based on the current time before forwarding it.
- If the command message is to be forwarded to the IDPU simulator, the SEP GSE will convert the stored message into the format expected by the IDPU simulator (24-bit command words).

The SEP GSE supports the forwarding of CCSDS command messages from the SEP sensor GSEs. The sensor team assembles their commands into a command message that is sent to a dedicated SEP GSE command Socket. The message format is described in section 4 above.

- When the SEP GSE receives the command messages and there are no time conflicts with other command messages, it forwards it to the IMPACT GSE.
- If the IMPACT GSE accepts the command message, the SEP GSE will send an acceptance notice back to the originator. If the IMPACT GSE does not accept the command message, or the SEP GSE detects a time conflict, the SEP GSE will return a rejection notice and discard the message.

## 6.3. Commanding Security

Command messages from the SEP sensor GSEs to the SEP GSE when sent over non-secure networks will use the same SSH-2 protocol that is used to send command messages between the IMPACT POCC and the MOC.

Command messages from the SEP GSE to the IMPACT GSE will use the same SSH-2 protocol.

Post-delivery, the default state will be that SEP commands will enter the command stream at the IMPACT POCC, not at the SEP GSE or the SEP sensor GSEs. The SEP team will provide commands to the IMPACT POCC via a separate secure channel.

#### **6.4. SEP GSE Telemetry Socket Server Software**

- The SEP GSE will act as a socket server that will provide telemetry to the telescope GSEs.
- Up to 12 TCP/IP connections
- The following telemetry packets will be forwarded over the socket connections:
  - All science packets with any SEP ApID
  - SEP housekeeping packets
  - SEP command response packets
  - Beacon data packets with SEP data

#### **6.5. Real Time Data Display**

##### **6.5.1. SEP GSE**

The SEP GSE provides real time displays of SEP housekeeping data (SEP temperatures, voltages, currents, etc.).

##### **6.5.2. Sensor GSEs**

The following is based on the LET GSE. Other SEP sensor GSEs perform similar functions:

- Filter the packets from the SEP telemetry that contain LET data.
- Build a set of standard data structures from the LET data.
- Build a standard set of real-time page displays for the information in the standard structures (may have more than one type of page display per structure.)
- Allow the user to select variables from the page displays to build time history plots.

#### **6.6. Non-Real time Data Analysis**

The SEP GSE software will include non-real-time software for further data examination. For SEP Central, this software is limited to the examination of housekeeping. For the LET GSE and the other sensor GSEs, the non-real-time software will also include the ability to examine the science data. For the LET GSE, the non-real-time software will have

- a set of IDL routines for generating a standard sets of plots from stored data,
- a set of IDL routines for accessing the stored data for reports, monitoring long-term trends, examining unusual incidents, ...

The non-real-time software for the other sensor GSEs will have similar capabilities.

#### **6.7. Data Logging**

##### **6.7.1. SEP GSE**

The SEP GSE logs the following packets to disk as they are received:

- All packets with any SEP ApId
- IMPACT housekeeping packets that contain SEP housekeeping data
- SEP command responses
- Beacon data packets

### **6.7.2. Sensor GSEs**

The sensor GSEs also log to disk the packets and standard data structures, reports, plots, etc. that they create from the data.

## **7. SEP GSE User Manual**

Here we will record all necessary instructions for running the SEP GSE, when they are available (**TBD-rgr**)

## **8. Other Services Provided to SEP by the Spacecraft**

The spacecraft provides three operational switched and current-monitored power services to IMPACT (IDPU/Mag/STE-U, SWEA/STE-D, and SEP), plus one to PLASTIC. These are controlled by the spacecraft and the Mission Operations Center, and cannot be controlled directly by the POCC. However, the IDPU can request that one or more of these systems be powered off in response to an error condition, and the POCC can trigger such a request via command to the IDPU.

Typically when an instrument is powered off, the spacecraft powers its survival heater on. SEP has several survival heaters. SEP also has a number of operational heaters powered via the SEP power service and controlled by SEP Central.

The spacecraft controls most of the IMPACT actuators directly, including SIT and SEPT one-time cover actuators. The IDPU and POCC cannot control these actuators; it must be done by the MOC.

The spacecraft also has 9 temperature sensors that it monitors in the IMPACT suite. These sensors are the only telemetry we get when the IDPU is off. The data from these sensors is part of the spacecraft telemetry, not the IMPACT telemetry, and will not be available to the POCC in real time (it will be part of the spacecraft status data provided non-real time to the POCC). Likewise the current monitors on the spacecraft power services is Spacecraft telemetry.