

**SAMPEX Special Pointing Mode**

F. Landis Markley, Thomas W. Flatley  
Guidance and Control Branch, Code 712  
NASA Goddard Space Flight Center,  
Greenbelt, MD 20771

Theodore Leoutsakos  
SMEX Flight Operations  
AlliedSignal Technical Services Corporation  
Seabrook, MD 20771

**Abstract**

A new pointing mode has been developed for the Solar, Anomalous, and Magnetospheric Particle Explorer (SAMPEX) spacecraft. This pointing mode orients the instrument boresights perpendicular to the field lines of the Earth magnetic field in regions of low field strength and parallel to the field lines in regions of high field strength, to allow better characterization of heavy ions trapped by the field. The new mode uses magnetometer signals and is algorithmically simpler than the previous control mode, but it requires increased momentum wheel activity. It was conceived, designed, tested, coded, uplinked to the spacecraft, and activated in less than seven months.

**Introduction**

The Solar, Anomalous, and Magnetospheric Particle Explorer (SAMPEX), the first of the Small Explorer series of spacecraft, was launched July 3, 1992 into an 82 degree inclination orbit with an apogee of  $\approx 670$  km and a perigee of  $\approx 520$  km [1]. The scientific purpose of SAMPEX is to study solar energetic particles, anomalous cosmic rays, magnetospheric relativistic precipitating electrons, and galactic cosmic rays. The spacecraft carries four instruments to carry out this mission: the Low Energy Ion Composition Analyzer (LEICA), the Heavy Ion Large Telescope (HILT), the MAAss Spectrometer Telescope (MAST), and the Proton Electron Telescope (PET).

Figure 1 shows the spacecraft mechanical configuration. The solar arrays are fixed with their outward normals along the spacecraft +y axis; power constraints require this axis to be sun-pointing at all times. The instrument fields-of-view all point along the spacecraft +z axis. The original instrument pointing requirement was to point the z-axis as closely to the local zenith as possible in the polar regions, consistent with the sun-pointing requirement [2-4]. The original SAMPEX attitude control mode was the Orbit Rate Rotation (ORR) mode with the y-axis always sun-pointed and the z-axis rotating around the sun line at one revolution per orbit, synchronized such that the z-axis points as close to zenith as possible when the spacecraft reaches the northernmost and southernmost points in its orbit [3-4]. A later requirement, known as "velocity avoidance" was to avoid pointing the instrument boresights in the direction of spacecraft motion, to avoid damage by orbiting debris to delicate thin multilayer entrance windows in the HILT instrument. An algorithm to accomplish this was incorporated into the ORR mode [3].

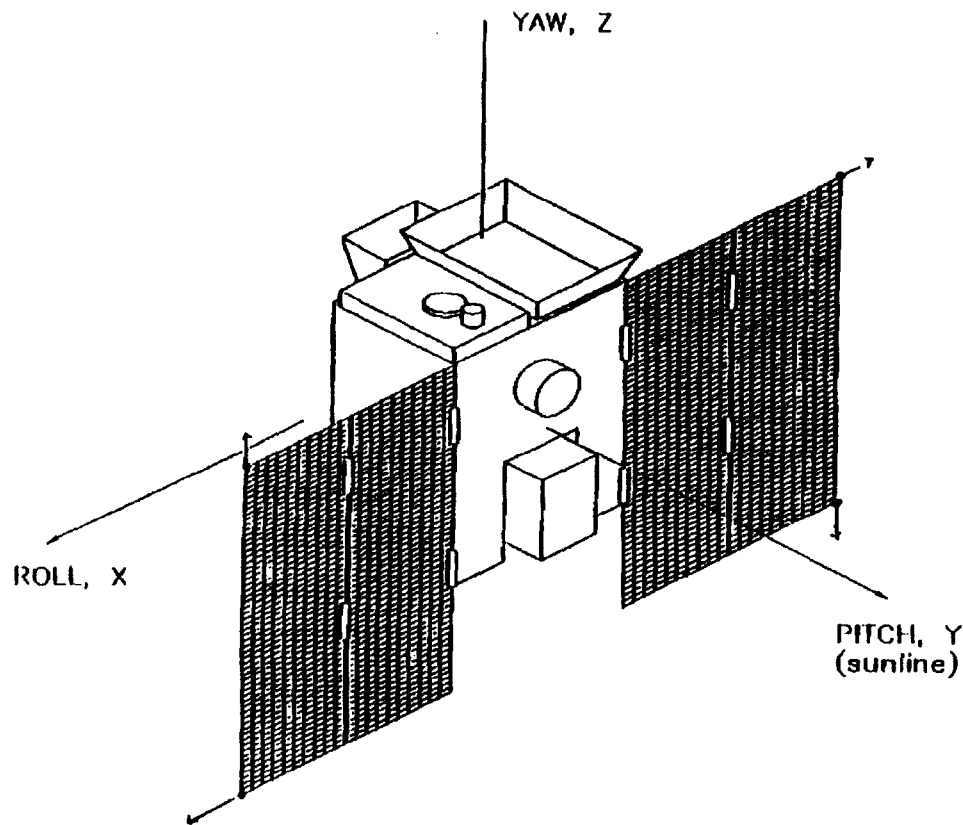
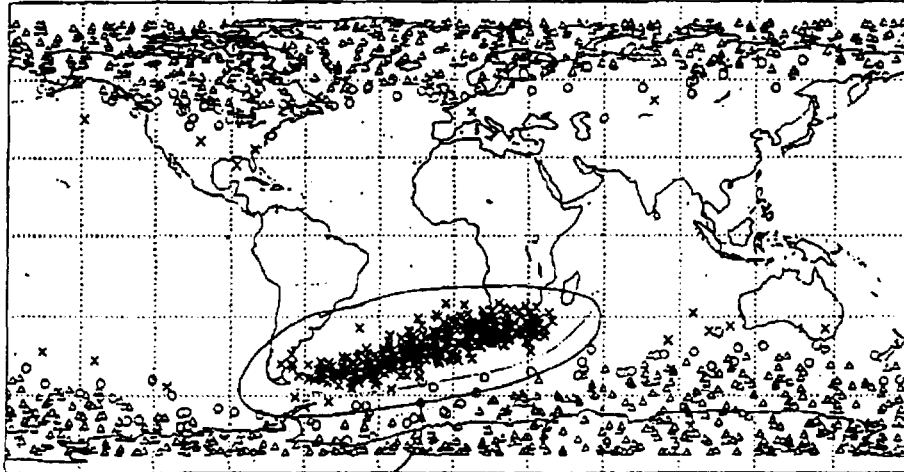

Figure 1. SAMPEX Configuration

Data taken during the first two years of the mission confirmed the existence of a third radiation belt surrounding the Earth, in addition to the two Van Allen belts containing trapped electrons and protons, respectively [5-7]. The new belt, whose existence had been predicted 15 years earlier, contains trapped heavy ions, principally O, N, and Ne. Figure 2 shows MAST Data on oxygen ions, including galactic cosmic rays (circles), anomalous cosmic rays (triangles) and trapped anomalous cosmic rays (crosses) [7]. Analysis of the MAST data showed that the trapped particles are observed primarily when the instrument is viewing near 90 degrees to the local magnetic field line. With the ORR pointing mode, this viewing angle varies with a three-month period. In order to increase data collection on the trapped heavy ions, it was desirable to change the pointing algorithm to orient the instrument boresights perpendicular to the magnetic field line during every passage through the regions containing these particles. Figure 2 served as the "requirements document" from Dan Baker, a project scientist, and Glenn Mason, the SAMPEX Principal Investigator, to investigate such a modification.

The region of most interest is in the South Atlantic, and analysis of the magnetic field contours shown in Figure 3 revealed that this region can be characterized as a region of low magnetic field strengths [8]. In order to satisfy these revised science requirements, the SAMPEX pointing mode was modified using the strength of the magnetic field as a delimiter to point the spacecraft perpendicular to the magnetic field vector whenever the field is determined to be less than some



John,  
This is the region where we would  
like SAMPEX always to be looking  
perpendicular to the local magnetic field  
line. It is to the East (and South) of  
the South Atlantic Anomaly region.  
Thanks  
Dan

SEPTEMBER 15, 1993

Volume 20 Number 18

Figure 2. Requirements Specification for SAMPEX Special Pointing Mode

specified value (e.g. 0.30 gauss). This pointing is accomplished by using magnetometer data to determine the field direction in the spacecraft reference frame. Since the magnetometer data was judged to provide a good pointing reference, the pointing specification was changed in the high-field regions to as close to the magnetic field vector as possible, consistent with the constraint that the y-axis be pointed at the sun. At northern latitudes, the desired orientation is anti-parallel to the field, and in the south the orientation is parallel to the field. In both cases, then, the spacecraft points away from the earth in the polar regions.

This paper contains a brief review of the SAMPEX attitude control system and a detailed discussion of the modifications for the new pointing mode. This is followed by a discussion of the testing and implementation of the new mode and initial on-orbit performance results.

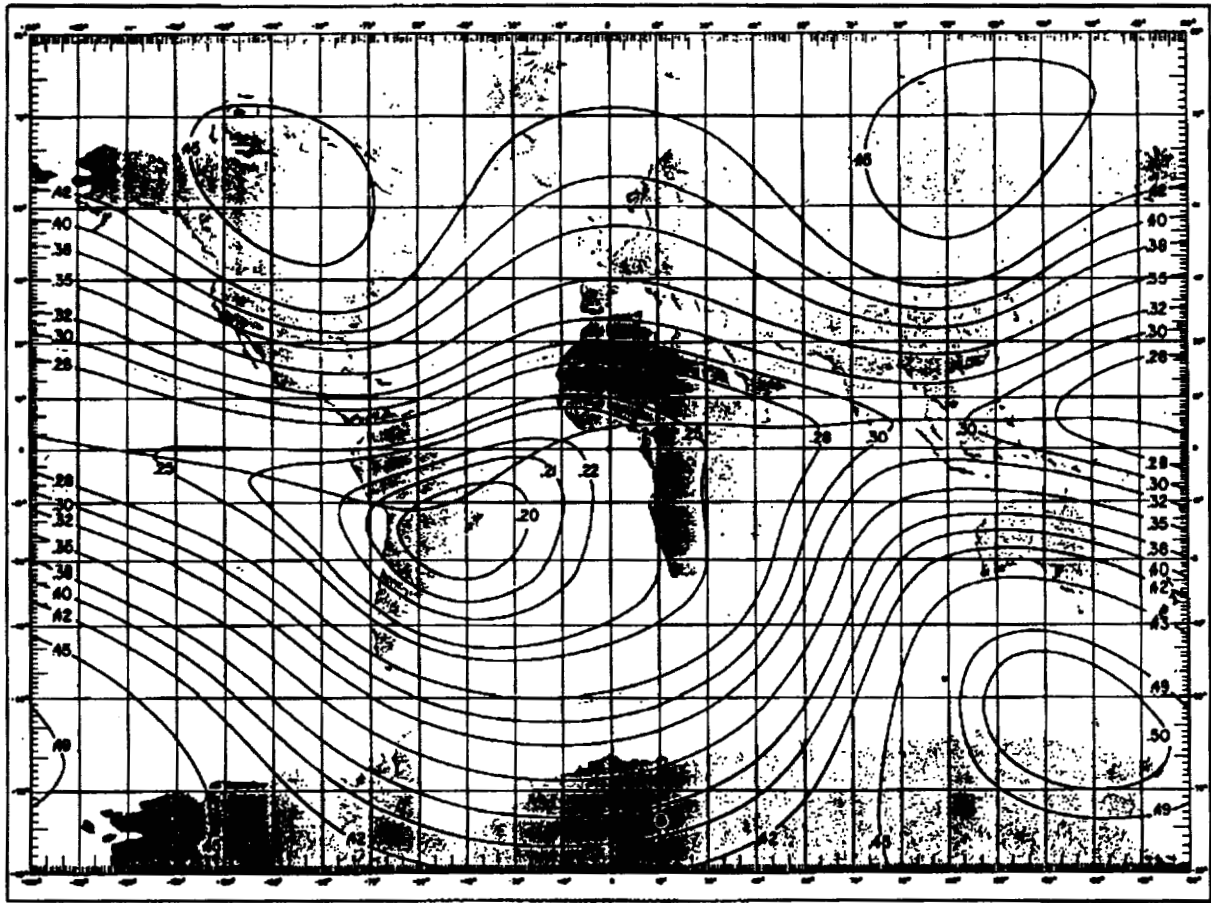

Figure 3. Lines of Constant Magnetic Field Strength (in Gauss) at 600 km Altitude

### SAMPEX Control Modes

The original SAMPEX attitude control system is described in References [2–4], so only a brief overview will be provided here. The attitude actuators in SAMPEX are an orthogonal triad of magnetic torquers and a single reaction wheel with its angular momentum along the  $y$  (pitch) axis. The reaction wheel angular momentum serves to keep the pitch axis sun-pointing even when the sun is behind the Earth, so that full power is available when SAMPEX emerges from eclipse.

The spacecraft attitude is estimated by means of the TRIAD algorithm, or "algebraic method" [9–11]. This requires knowledge of two vectors in both the spacecraft body frame and an inertial reference frame. When SAMPEX is in sunlight, these are the ambient magnetic field vector ( $\mathbf{b}$  in the body frame and  $\mathbf{B}$  in the inertial frame) and the unit vector to the sun ( $\mathbf{s}$  in the body frame and  $\mathbf{S}$  in the inertial frame). The magnetic field vector and sun unit vector in the spacecraft body frame are computed from three-axis magnetometer (TAM) and digital sun sensor (DSS) measurements, respectively. The inertial magnetic field vector is computed from an onboard spacecraft ephemeris and International Geomagnetic Reference Field model [12], and the inertial sun vector is computed

from an onboard solar ephemeris. When SAMPEX is in eclipse, the spacecraft pitch axis vector

$$\mathbf{j} \equiv [0 \ 1 \ 0]^T \quad (1)$$

is substituted for the DSS-measured sun vector  $\mathbf{s}$ , which is unavailable; and these are used along with  $\mathbf{b}$ ,  $\mathbf{S}$ , and  $\mathbf{B}$  for attitude determination. This assumes that the angular momentum stiffness of the wheel keeps the pitch axis direction from drifting significantly during eclipse.

The spacecraft angular velocity is computed by differentiating the TRIAD-computed attitude matrix  $A$ ;

$$\begin{bmatrix} 0 & \omega_3 & -\omega_2 \\ -\omega_3 & 0 & \omega_1 \\ \omega_2 & -\omega_1 & 0 \end{bmatrix} = \frac{1}{2} \left[ \dot{A}A^T - (\dot{A}A^T)^T \right]. \quad (2)$$

Then the total spacecraft angular momentum is given by

$$\mathbf{H} = I\boldsymbol{\omega} + \mathbf{H}_w, \quad (3)$$

where  $I$  is the spacecraft moment-of-inertia tensor and  $\mathbf{H}_w$  is the reaction wheel angular momentum. The computed values of  $\boldsymbol{\omega}$  are very noisy because of the 0.5 degree resolution of the DSS, so the system angular momentum  $\mathbf{H}$  is filtered with a first-order lag (or "constant gain Kalman filter") with a time constant of 50 seconds [4].

The magnetic torquers are used to control the magnitude and direction of the system angular momentum when SAMPEX is in sunlight. The desired angular momentum magnitude, denoted by  $H_0$ , is 0.6 Nms. The desired direction is along the pitch axis (to damp spacecraft nutation), and along the sunline (to keep the solar arrays sun-pointing). Thus an undesired component of spacecraft angular momentum  $\Delta\mathbf{H}$  can be computed as

$$\Delta\mathbf{H} = (\mathbf{H} - H_0\mathbf{j}) + (\mathbf{H} - H_0\mathbf{s}) = 2\mathbf{H} - H_0(\mathbf{j} + \mathbf{s}). \quad (4)$$

The magnetic torquers are commanded to have dipole moment

$$\mathbf{m} = k_{mag}\Delta\mathbf{H} \times \mathbf{b}, \quad (5)$$

where  $k_{mag}$  is a constant gain. The magnetic control is turned off during eclipse, since motion of the angular momentum vector is undesirable when DSS data are unavailable.

Reaction wheel torque commands are used to control spacecraft pitch motion, the rotation about the pitch axis. These commands are based on the calculation of a "target vector" in body coordinates, with the reaction wheel being torqued to bring the z-axis into alignment with the target. The orbit rate rotation (ORR) computation of the target vector resulted in slowly varying reaction wheel speed and spacecraft pitch rate [3, 4]. Since the "Special Pointing" mode replaces ORR, this computation will not be discussed here. The actual computation of the pitch error and of the reaction wheel commands are in References [2-4] and will not be repeated, either.

Attitude determination is adversely affected if the magnetic field vector and the sun vector are close to parallel. On SAMPEX, in sunlight, attitude calculations and pitch control are both inhibited if these vectors are within 5 degrees of each other. In the dark, these functions are inhibited in the larger exclusion region where the angle is less than 40 degrees, since unavoidable angular momentum drift also adversely affects attitude determination accuracy in eclipse. This disabling of pitch control during periods of coalignment of the magnetic field and sun vectors is referred to as "coast mode." The pitch control was disabled in ORR by "freezing" the reaction wheel speed at the value it had at entry to coast mode, which resulted in a constant pitch rate through the coast. Magnetic control continues to be exercised in coast mode in sunlit portions of the orbit.

### Special Pointing Mode

The new Special Pointing mode modifies the calculation of the target vector to meet the revised pointing requirements outlined above. Different calculations are used in the high-field-strength and low-field-strength regions. The ephemeris-based inertial field  $\mathbf{B}$  is used to distinguish these regions, since use of the TAM-based field  $\mathbf{b}$  could result in toggling between the two regimes due to measurement noise.

In the low-field region,  $|\mathbf{B}| \leq 0.3$  Gauss, the target vector  $\mathbf{u}$  is to be perpendicular to both the sun vector  $\mathbf{s}$  and the magnetic field vector  $\mathbf{b}$ . This requirement is obviously satisfied by choosing the target vector in the direction of the cross product  $\mathbf{s} \times \mathbf{b}$ . The negative of this vector clearly satisfies the same requirement. One and only one of these two vectors is more than 90 degrees from the velocity vector, and we choose this one to satisfy the velocity avoidance requirement. Since the magnetic control keeps the sun vector within a few degrees of the pitch axis vector  $\mathbf{j}$ , the cross product  $\mathbf{s} \times \mathbf{b}$  can be well approximated by  $\mathbf{j} \times \mathbf{b}$ , so the target vector is computed as

$$\mathbf{u} = \frac{\pm 1}{\sqrt{b_1^2 + b_3^2}} \begin{bmatrix} b_3 \\ 0 \\ -b_1 \end{bmatrix}, \quad (6)$$

where we choose the upper sign if  $\mathbf{V} \cdot (\mathbf{S} \times \mathbf{B}) \leq 0$  and the lower sign if  $\mathbf{V} \cdot (\mathbf{S} \times \mathbf{B}) > 0$ , with  $\mathbf{V}$  being the spacecraft velocity vector in inertial coordinates, which is computed from the onboard ephemeris. Note that ephemeris-computed vectors in the inertial frame are used to make binary decisions, in order to prevent toggling between grossly different pointing vectors; but that the TAM-sensed magnetic field vector in the body frame is used to compute the actual pointing vector.

The angle between the target vector and the body z-axis is computed as a pitch error angle, which is used to generate a wheel command. This angle is generally small, but it is on the order of 90 degrees during transitions between parallel pointing and perpendicular pointing. In these cases, the wheel is commanded in the direction that requires the smallest pitch rotation to null the pitch error. Due to changing geometry however, some time during a passage through a low field region, a 180 degree pitch maneuver is generally required to satisfy the avoidance requirement. The Special Pointing algorithm assures that any 180 degree turns will be executed in a direction away from the velocity vector. Thus a computed pitch error angle magnitude greater than 2.5 radians is taken to signify a large reorientation maneuver. The sign of the x-axis component of the spacecraft velocity

vector  $\mathbf{v}$  in the body frame is then used to determine the direction of this maneuver, such that the instrument boresights are rotated away from the velocity vector rather than toward it.

In the high-field region,  $|\mathbf{B}| > 0.3$  Gauss, the target vector  $\mathbf{u}$  is to be perpendicular to pitch axis and as close as possible to parallel or antiparallel to the magnetic field vector  $\mathbf{b}$ . Thus the target vector is given by

$$\mathbf{u} = \frac{\pm 1}{\sqrt{b_1^2 + b_3^2}} \begin{bmatrix} b_1 \\ 0 \\ b_3 \end{bmatrix}, \quad (7)$$

where the positive sign is used when SAMPEX is in the southern hemisphere and the negative sign in the northern hemisphere, as determined from the onboard ephemeris. In the high-field region the existing onboard velocity avoidance algorithm [3] is still used.

During "coast mode," the reaction wheel speed angular momentum is commanded to the fixed value of 0.6 Nms, rather than to its instantaneous value at entry to coast mode as in the ORR mode. Since the total system angular momentum is maintained at 0.6 Nms by magnetic torquer commands, this has the effect of halting spacecraft attitude motion in coast mode. This change was necessitated by the observation that coast mode could be entered during one of the rapid 90 degree or 180 degree repointings of the spacecraft, and holding the spacecraft pitch rate constant at a high value could result in several pitch rotations during coast mode. This undesirable behavior was actually seen in some simulations, but is avoided by the final pointing law.

### Simulations

Figures 4 and 5 show the results of simulations of the new Special Pointing mode. These simulations were performed using a modified version of the FORTRAN program used to simulate the earlier SAMPEX pointing algorithms. The performance of the SAMPEX pointing modes depends on the relative orientation of the sun vector and the orbit plane, which is specified by the local time of the ascending node of the orbit. This local time is 6 am for the simulation of Figure 4 and noon for Figure 5. Figure 6 shows a simulation of the ORR pointing mode for the same noon orbit as is illustrated in Figure 5. All these figures show only the first five hours of 25-hour simulations. The 25-hour length of the simulations was chosen to sample the full range of magnetic field geometries as the Earth completes a little more than one full rotation. In each case, the remaining 20 hours of the simulation were qualitatively similar to the five hours shown. Simulations of a 9 am orbit gave results intermediate between those shown in Figures 4 and 5.

The upper plot in the first (a) half of each figure shows the magnetic field strength. Shading is used to highlight the low-field regions, i.e. the regions with  $|\mathbf{B}| \leq 0.3$  Gauss, where pointing perpendicular to the field line is desired. The Special Pointing mode attempts to point parallel or antiparallel to the field lines in the unshaded regions. The coast mode flag is also shown on this plot; there are no coast mode intervals in the 6 am orbit and several in the noon orbit. The 9 am orbit, which is not shown, had only two eclipse coast mode intervals in the five hour period.

The curve below the magnetic field strength plots shows the angle between the instrument boresights and the local zenith. After an initial transient, this is always less than 90 degrees for the

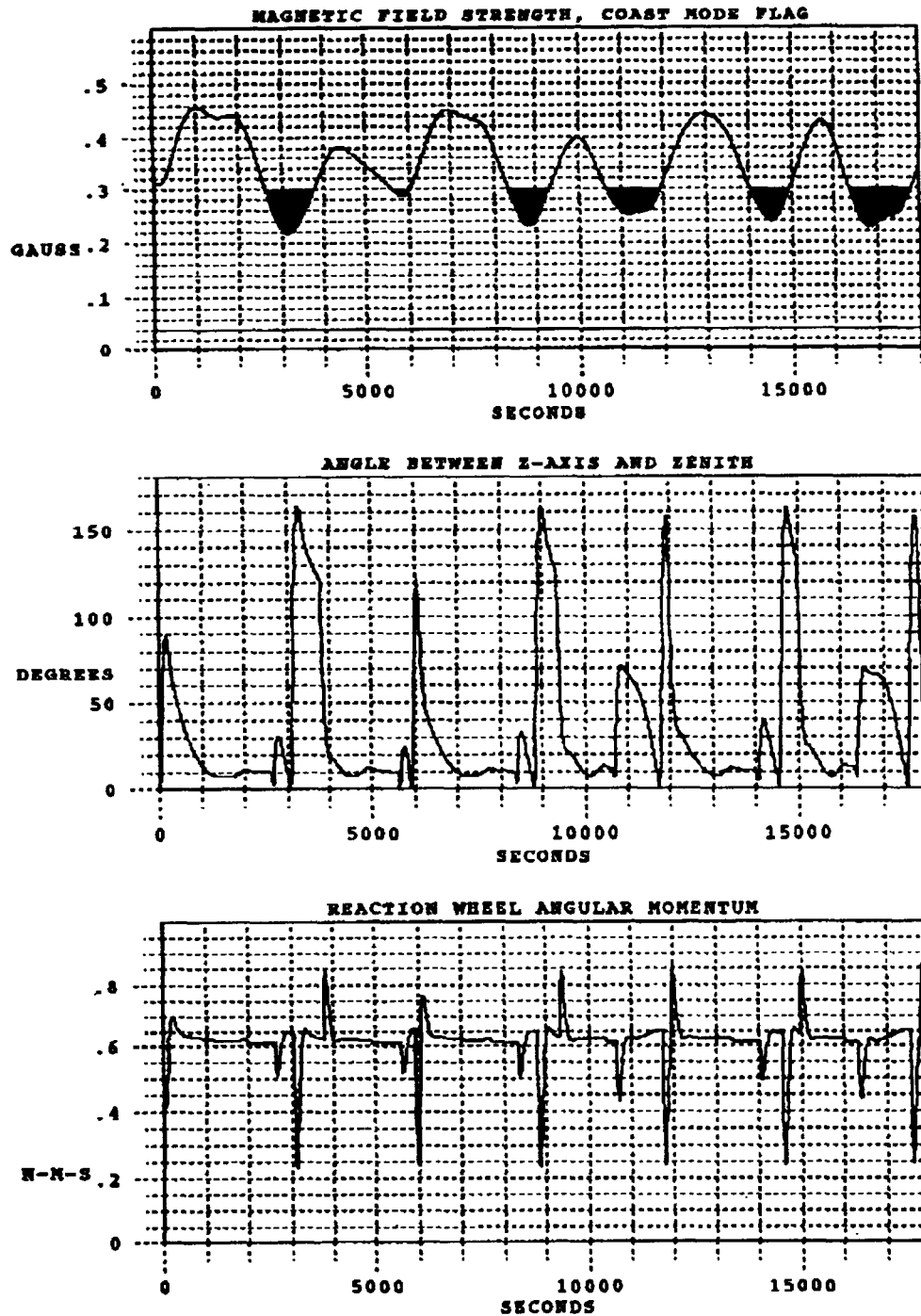

Figure 4a. Simulation of SAMPEX Special Pointing Mode for a 6 am Orbit  
 Magnetic field strength, coast mode flag, zenith angle, reaction wheel angular momentum



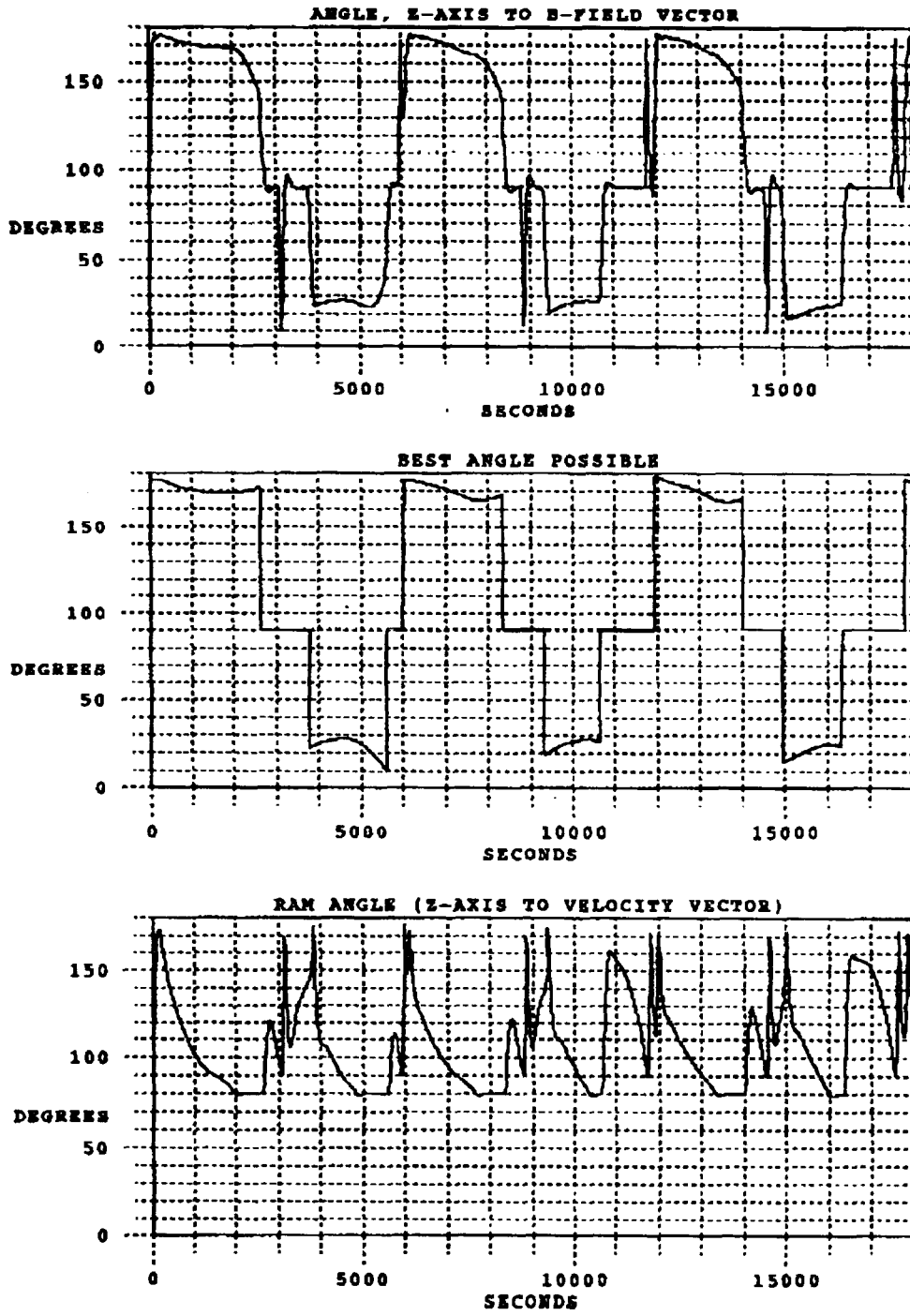

Figure 4b. Simulation of SAMPEX Special Pointing Mode for a 6 am Orbit Instrument boresight to magnetic field angle, ram angle

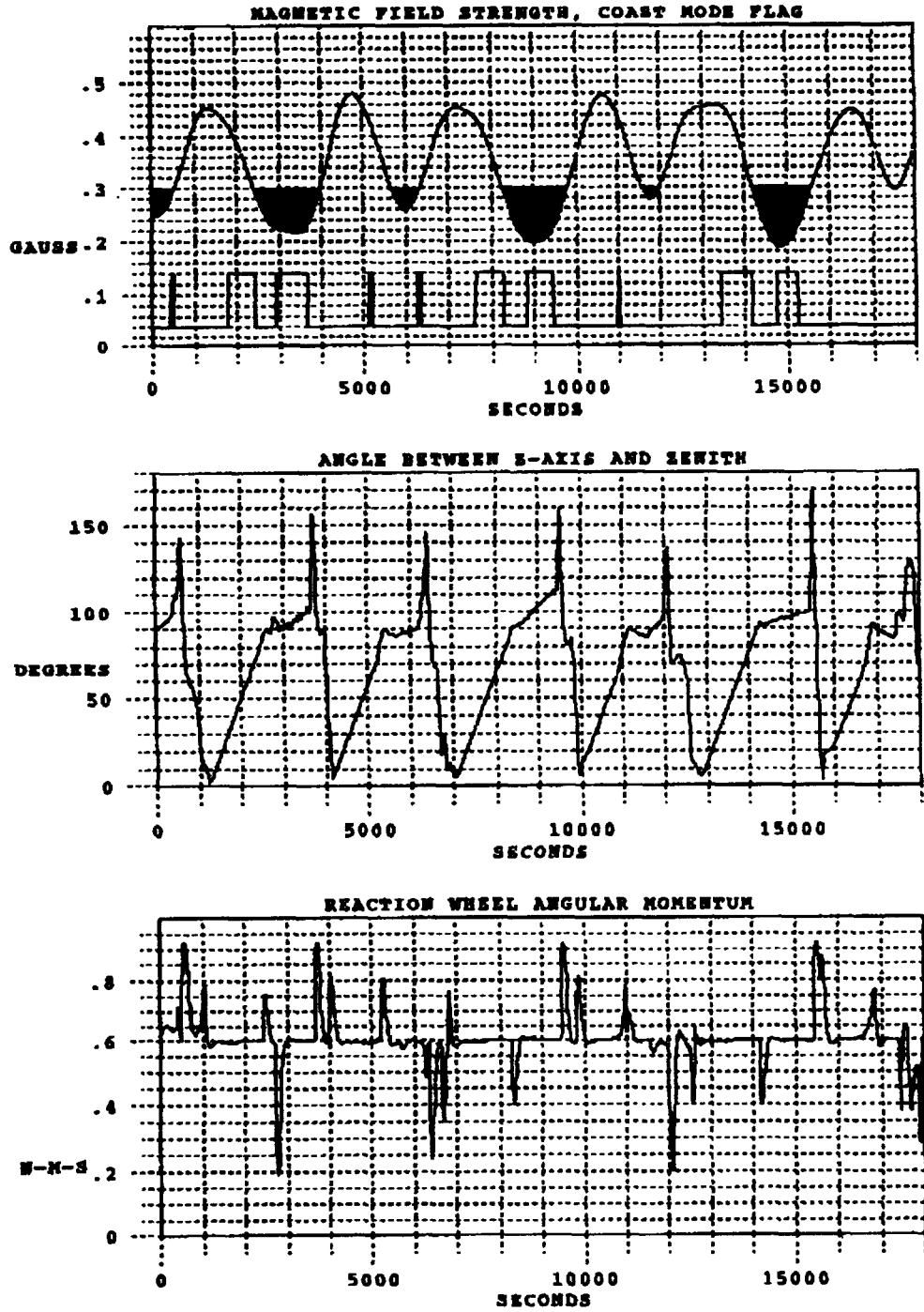

Figure 5a. Simulation of SAMPEX Special Pointing Mode for a Noon Orbit  
 Magnetic field strength, coast mode flag, zenith angle, reaction wheel angular momentum

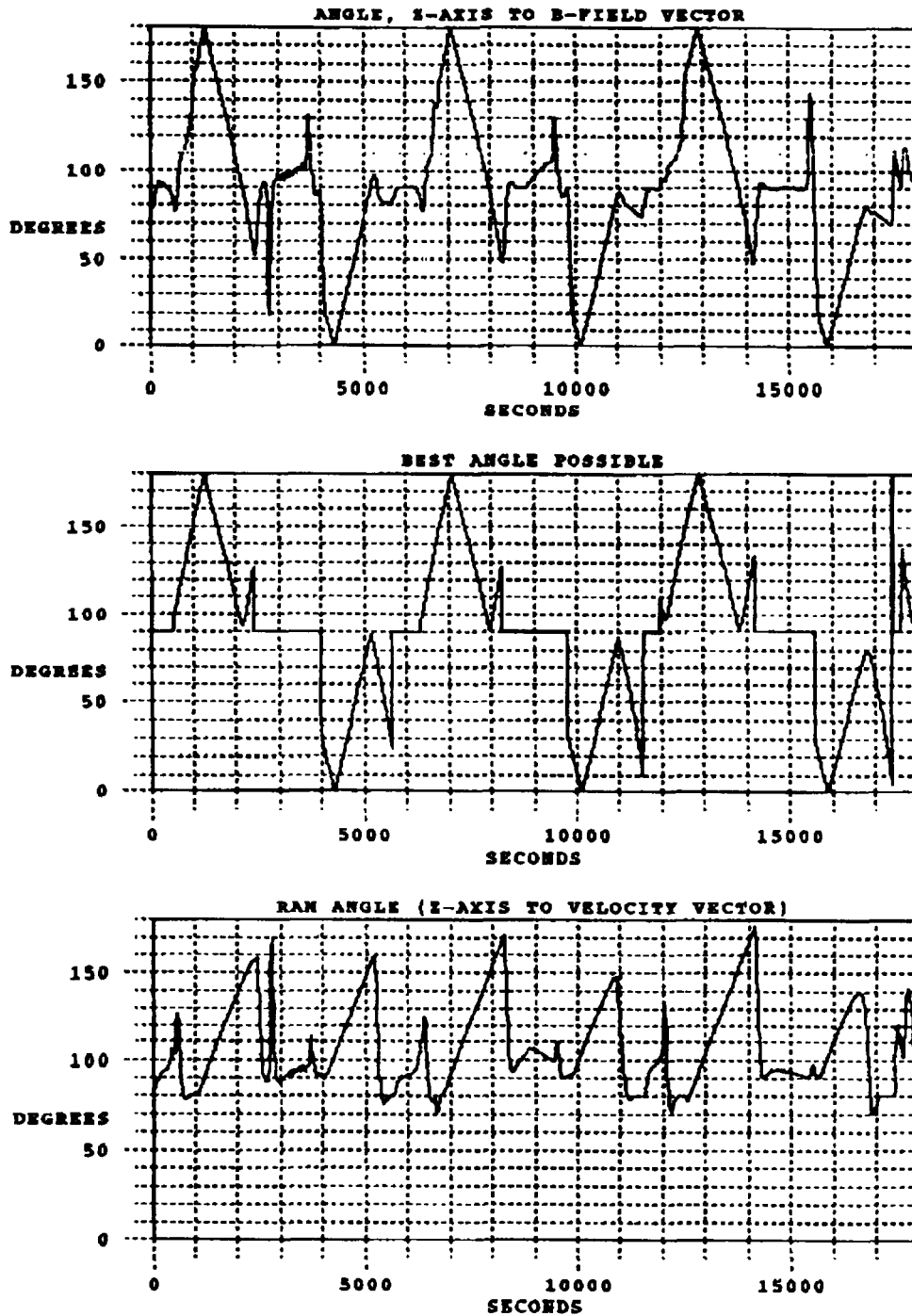

Figure 5b. Simulation of SAMPEX Special Pointing Mode for a Noon Orbit Instrument boresight to magnetic field angle, ram angle

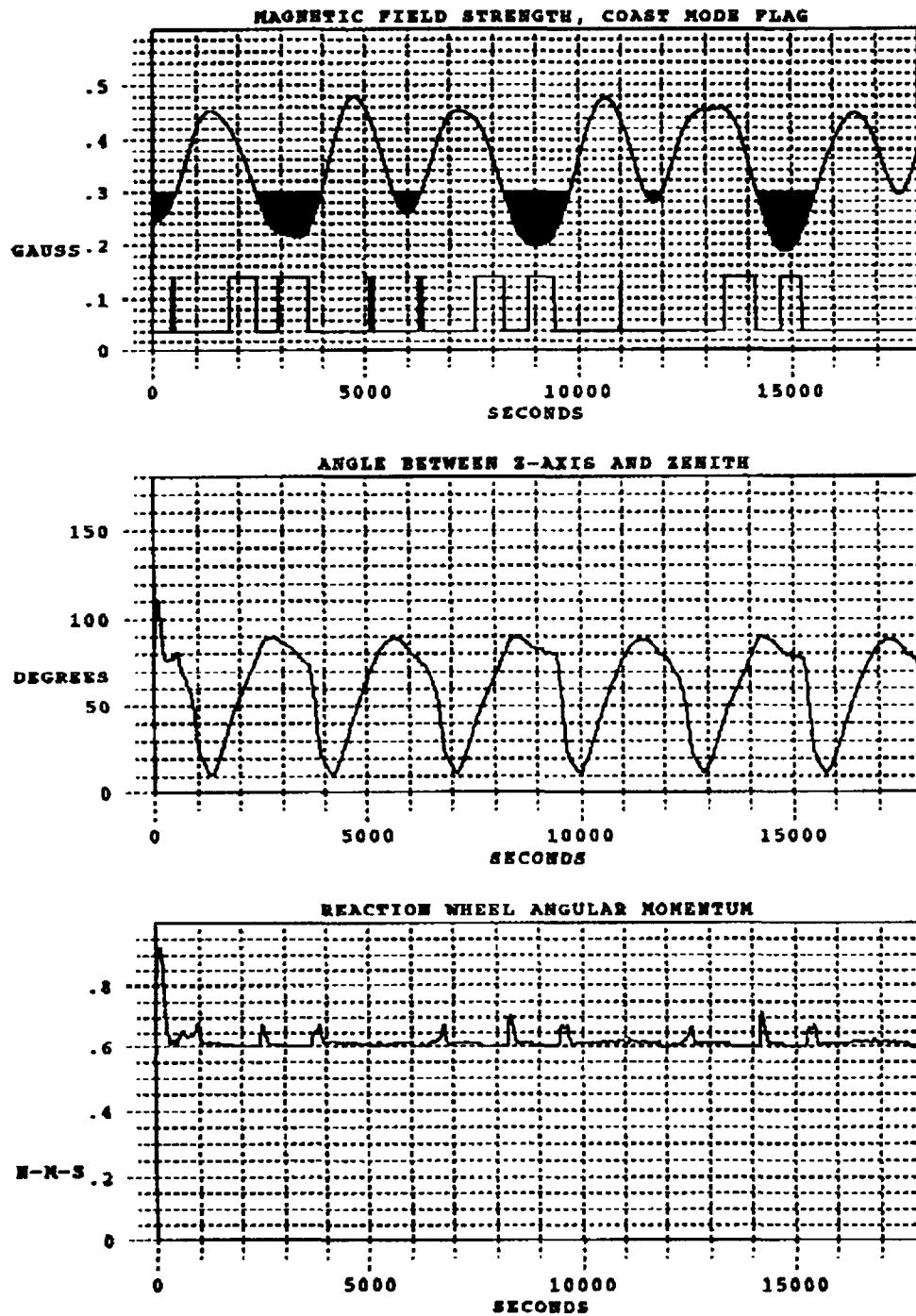

Figure 6a. Simulation of SAMPEX Orbit Rate Rotation Mode for a Noon Orbit  
 Magnetic field strength, coast mode flag, zenith angle, reaction wheel angular momentum

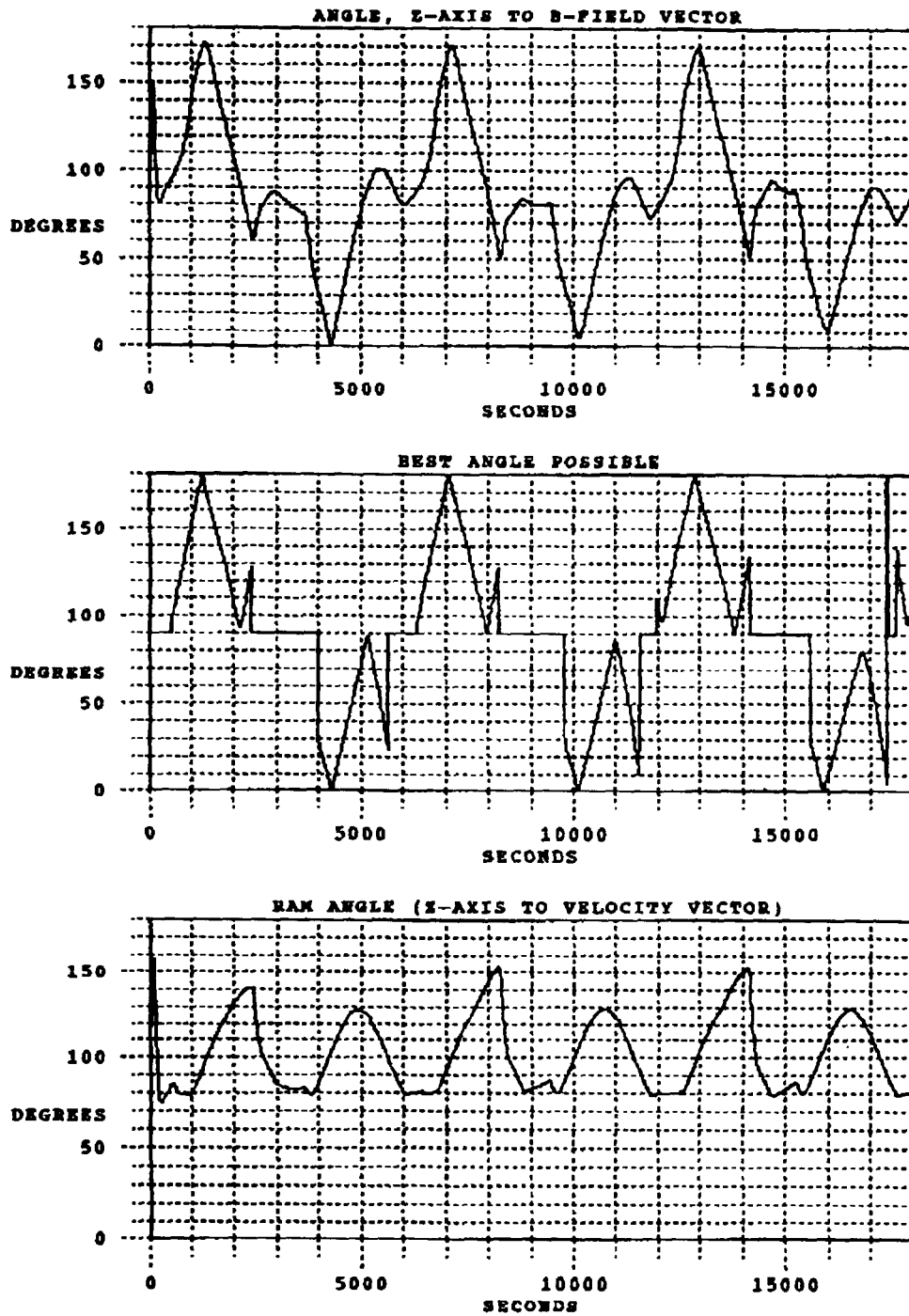

Figure 6b. Simulation of SAMPEX Orbit Rate Rotation Mode for a Noon Orbit Instrument boresight to magnetic field angle, ram angle

ORR simulation shown in Figure 6. This means that the instruments are always pointing generally away from the Earth in the ORR mode. This angle often exceeds 90 degrees when the Special Pointing mode commands pointing perpendicular to the magnetic field lines. This is required for velocity avoidance in this case, and does not cause any problems for the data collection. The plots at the bottom of the (a) part of each of the figures show the reaction wheel angular momentum. These indicate the increased reaction wheel activity required by the Special Pointing mode.

The upper plot in second (b) half of each pair of plots shows the simulated angle between the instrument boresights and the magnetic field lines. This should be compared with the plot immediately below, which shows the ideal pointing angle. This is the best angle possible, consistent with the requirement that the SAMPEX y-axis be sun-pointing, but ignoring velocity-avoidance constraints. It can be seen that the Special Pointing mode comes quite close to ideal pointing in most cases. The spikes in the upper curve in Figure 4 at about 3200 sec, 7800 sec, and 14,600 sec are due to the 180 degree velocity avoidance maneuvers in the perpendicular-pointing region that were discussed above. Some of these spikes, slightly shifted in time, appear in Figure 5 as well. The bottom plot of the (b) half of each figure shows the ram angle, the angle between the instrument boresights and the spacecraft velocity. The velocity avoidance algorithm was set to restrict this angle to be greater than 80 degrees. This constraint is satisfied in the most part, but there are minor violations in coast mode.

### **Implementation**

Actual implementation of the modified pointing law required changes to the computer code in the Recorder/Packetizer/Processor (RPP) onboard the spacecraft. A formal Configuration Control Request (SAMPEX CCR# RPP-015) was submitted to the SAMPEX Flight Software Configuration Control Board (CCB). The algorithms were transmitted from the Guidance and Control Branch, Code 712, to the Flight Software Systems Branch, Code 512, for conversion into flight code. Flight Software Systems personnel developed a patch to the existing onboard software and tested it in the Code 512 Software Development and Validation Facility (SDVF), which includes a flight-like RPP. Extensive simulations were performed to match the results of the Code 712 simulations. After thorough review of the code and simulation results by both the CCB and the scientists, the modified software was approved by the CCB, uplinked to the spacecraft, and activated on May 26, 1994, less than seven months after initial request by project scientists to develop the new pointing mode.

### **Discussion**

The development of the new "Special Pointing" mode for SAMPEX shows the advantage of having a flexible, reprogrammable attitude control system on a spacecraft. The rapid development of space-qualified microprocessor-based control systems makes it possible to provide such systems even on the small, light, and inexpensive Small Explorer spacecraft. The payoff is that the control algorithms can be modified to address revised science requirements responding to new opportunities revealed by data collected in the early part of a mission. The rapid development of the new SAMPEX pointing algorithms in less than seven months from initial expressions of interest by project scientists to operational flight code also serves as an example of outstanding teamwork and cooperation between scientists, engineers, programmers, and flight operations personnel.

The new algorithm is algorithmically much simpler than the orbit rate rotation control, but it results in frequent pitch reorientations to meet the new requirements. These use more spacecraft power, and also put more stress on the reaction wheel. Neither power nor reaction wheel life is a concern, however, since the SAMPEX power system has more than adequate margins to meet the increased demands, and the reaction wheel was designed and qualified for flight environments much more demanding than SAMPEX. Initial experience with the new pointing mode has been trouble-free, and the prospects for new science are exciting.

### References

- [1] D. N. Baker, G. M. Mason, O. Figueroa, G. Colon, J. G. Watzin, and R. M. Aleman, "An Overview of the Solar, Anomalous, and Magnetospheric Particle Explorer (SAMPEX) Mission," *IEEE Transactions on Geoscience and Remote Sensing*, Vol. 31, No. 3, pp. 531–541, May 1993
- [2] Thomas W. Flatley, Josephine K. Forden, Debra A. Henretty, E. Glenn Lightsey, and F. Landis Markley, "On-board Attitude Determination and Control Algorithms for SAMPEX," NASA/GSFC Flight Mechanics/Estimation Theory Symposium, Greenbelt, MD, May 22–24, 1990
- [3] Joseph P. Frakes, Thomas W. Flatley, Josephine K. San, Debra A. Henretty, F. Landis Markley, and E. Glenn Lightsey, "SAMPEX Science Pointing with Velocity Avoidance," AAS/AIAA Spaceflight Mechanics Meeting, Colorado Springs, CO, February 24–26, 1992
- [4] Jon D. McCullough, Thomas W. Flatley, Debra A. Henretty, F. Landis Markley, and Josephine K. San, "Testing of the On-board Attitude Determination and Control Algorithms for SAMPEX," NASA/GSFC Flight Mechanics/Estimation Theory Symposium, Greenbelt, MD, May 5–7, 1992
- [5] Douglas Birch, "Earth Has Third Zone of Radiation," *Baltimore Sun*, Vol. 313, No. 9, p. 16A, May 26, 1993
- [6] Vincent Kiernan, "Small Explorer Satellite Finds Radiation Belt," *Space News*, March 31–June 6, 1993
- [7] J. R. Cummings, A. C. Cummings, R. A. Mewaldt, R. S. Selesnick, E. C. Stone, and T. T. von Rosenvinge, "New Evidence for Geomagnetically Trapped Anomalous Cosmic Rays," *Geophysical Research Letters*, Vol. 20, No. 18, pp. 2003–2006, September 15, 1993
- [8] E. G. Stassinopoulos, "World Maps of Constant B, L, and Flux Contours," NASA SP-3054, Goddard Space Flight Center, 1970
- [9] H. D. Black, "A Passive System for Determining the Attitude of a Satellite," *AIAA Journal*, Vol. 2, No. 7, pp. 1350–1351, July, 1964
- [10] G. M. Lerner, "Three-Axis Attitude Determination," in *Spacecraft Attitude Determination and Control*, J. R. Wertz (editor), D. Reidel, Dordrecht, Holland, 1978
- [11] M. D. Shuster and S. D. Oh, "Three-Axis Attitude Determination from Vector Observations," *Journal of Guidance and Control*, Vol. 4, No. 1, pp. 70–77, January–February, 1981
- [12] R. A. Langel, "International Geomagnetic Reference Field: The Sixth Generation," *Journal of Geomagnetism and Geoelectricity*, Vol. 44, pp. 679–707, 1992